



## Bid Bulletin No. 9

September 11, 2020

### PUBLIC BIDDING No. 20 – 022– 3

## CONSTRUCTION OF ASCOM FACILITIES AT CAMP AQUINO, TARLAC FOR THE BASES CONVERSION AND DEVELOPMENT AUTHORITY

Issued pursuant to Sec. 22.5 of the IRR of R.A. 9184 to clarify and/or amend<sup>1</sup> certain provisions in the Bidding Documents issued for this project, considering the issues raised and clarifications made by prospective bidders during the **Pre-Bid Conference** held on **14 August 2020**, likewise, respond to bidders' written queries received within the prescriptive period for filing.

### I. Clarification/s:

| REFERENCE/AMENDMENT  | JUSTIFICATION/ EXPLANATION  |
|--|---|
| May we request for an extension for the opening of bids. Our reason is to have more time to work on detailed estimates and BOQ form.   | Please refer to Bid Bulletin No. 8 dated September 07, 2020.  |
| Re. Construction safety and health program, did you already consider in the ABC the Protocol for the New Normal due to the on-going Pandemic (Sanitation Area, Rapid test/swab test and PPE's)?  | Please refer to Bid Bulletin No. 2 dated August 19, 2020  |
| Should we put paging on the document that we will submit?  | Page numbering shall be at the discretion of the bidder. It is however suggested that bid submissions should at least be indexed to properly account the documents. |
| 1002.2.33 Programmable Divider: Detail not found in the Sanitary Plan. Division 2 & 3 Part C & I Technical Data Sheet. Also included in the BOQ  | Please disregard "Programmable Divider", this is part of Water Treatment Plant (WTP) System to be done by the "WTP Design & Build" Specialized Vendor.              |
| 1201(17) Supply/Installation of multimedia/activated carbon filter system (depth filter), water softener & chlorination including other necessary accessories to complete the system: is this included in the BOQ or Estimate? While stated in the Technical Specs to be supplied and installed by others. | This Item 1201(17) is also part of the scope of "WTP Design & Build" Specialized Vendor.  |

<sup>1</sup> For the purpose of this Bulletin and for better understanding of its contents, the following rules shall apply: (a) ~~Double Strike out~~ – denotes deletion; (b) Underline – denotes inclusion or new item/requirement; and "xxx" – denotes separation of phrase/s being amended from the rest of the main text.

| REFERENCE/AMENDMENT   | JUSTIFICATION/<br>EXPLANATION  |
|---|--|
| <p>Bid Data Sheet 31.4(f) 1. Construction schedule 2. Manpower schedule 3. Construction method 4. Equipment Utilization schedule &amp; 4. CSHP are the Bidders required to submit during the bidding</p>  | <p>Those documents shall form part of the Contract, to be submitted by the Winning Bidder prior signing of the Contract.</p>   |
| <p>Upon checking in Procurement Service website, the Pre-bid Minutes last Aug 14 is not yet uploaded. May we request the e-file of Pre-bid Minutes</p>  | <p>Minutes of the Pre-Bid Conference was uploaded on PS website on August 19, 2020.</p>  |
| <p>Are bidders required to submit Key Personnel's Affidavit of Commitment to Work on the Contract? If yes, may we request for the format or form to be use.</p>   | <p>Please refer to Section IX "Bidding Forms", page 83 of the Bidding Document.</p>  |
| <p>Please confirm if Foreman is required in the List of Minimum Key Personnel to be assigned to the project.</p>  | <p>Please refer to BDS Clause 12.1(b)(ii.2) for the "List of Minimum Key Personnel Nominated/To Be Assigned to the Project"</p>  |
| <p>May we inquire if the submission of a PCAB license which is in process for renewal will be a ground for disqualification of bid?</p>   | <p>Yes. Bidders are required to submit a valid PCAB license during submission of bids. In case of Joint Venture, a valid Special PCAB license is required. Please refer to BDS 5.1 and ITB Section 12.1(a)(iii).</p> |
| <p>We would like to inquire if there is a need to provide Six (6) Transit Mixer with a capacity of Six (6) cubic meter as required in the list of equipment to be provided in the execution of the project.</p> <p>Transit mixers will be provided by our Ready Mixed Concrete suppliers.</p> | <p>Yes, bidders are required to provide all the equipment with the required capacity, as required in the List of Equipment to be provided in the execution of the project.</p>                                       |

**STRUCTURAL**

**SECTION VII  
Drawings  
Volume 2  
S31-1**

Please confirm if the ties is spaced at 400mm (conflict with the drawing)

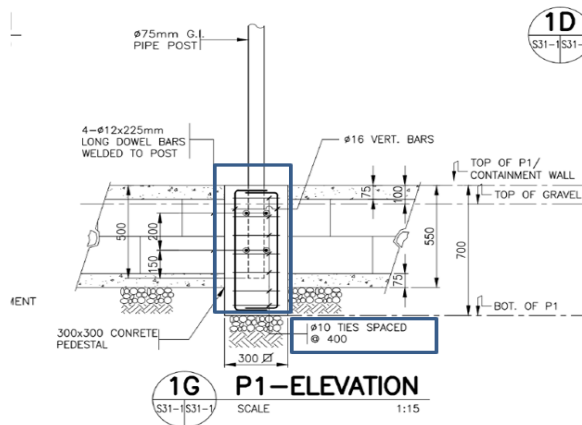

Ties are spaced at 100mm.

**S13-5**

Please verify if the corbel to be used in Building 13 is concrete, conflict with the BOQ (steel corbel)

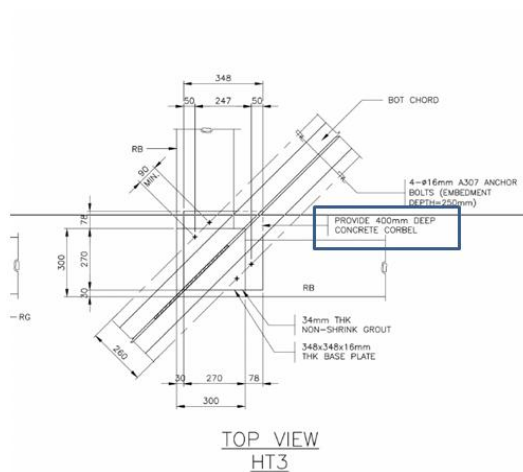

Concrete corbel shall be used.

**375.3126**

Structural Steel, Steel Corbel (Channel Bar Sections)

Concrete corbel shall be used.

**Site Development**

Please confirm if Item 1201(3); deep well, is temporary only for the project duration

The provision of deep well is permanent for the development of the Project, since it is the main source of water for ASCOM Facilities in Tarlac.

**S11-2/S11-9**

Please verify the location of STC-1, if STC-1 necessary in gridline 2

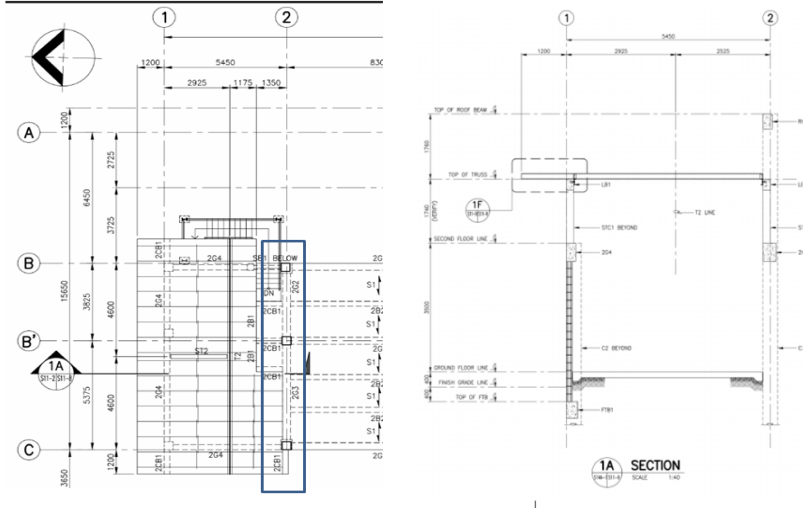

Refer to A11-3 for Wall plan and ST-2 detail 3 for SC locations.

**ARCHITECTURAL**

**SECTION VII  
Drawings  
Volume 2  
A20-2**

Kindly confirm if this is the door tagging for Building 20, conflict with the door schedule

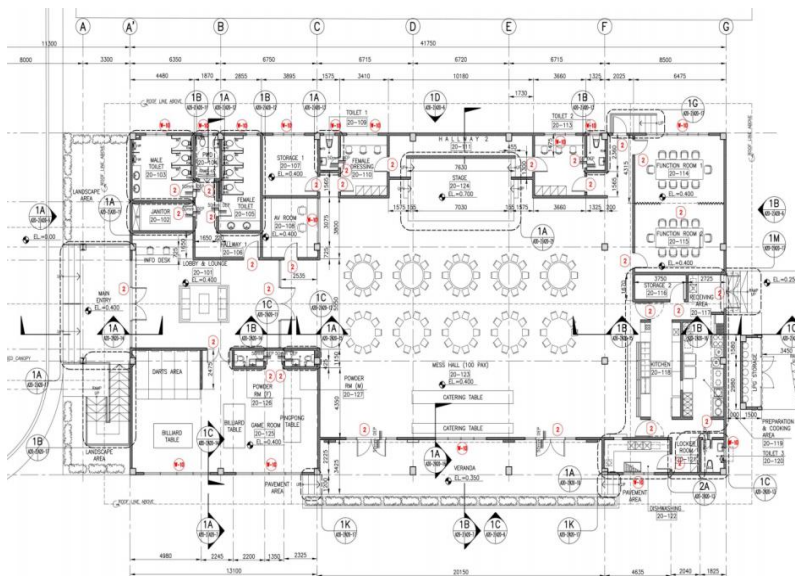

Refer to attached drawing file for the door & window tag.

All other provisions of the bidding documents affected by this amendment are deemed modified or amended accordingly.

Amendments made herein shall be considered an integral part of the Bidding Documents.

**SGD.**  
**ENGR. JAIME M. NAVARRETE, JR.**  
*Chairperson, SBAC*