



Republic of the Philippines
Department of Budget and Management
PROCUREMENT SERVICE
BIDS AND AWARDS COMMITTEE



Bid Bulletin No. 3
May 10, 2019

Public Bidding No. 19-140-2

**PRINTING, SUPPLY AND DELIVERY OF GRADE 8 LEARNING RESOURCES
FOR THE DEPARTMENT OF EDUCATION (DEPED)**

This Bid Bulletin is being issued to amend¹ portions of the bidding documents. Specifically, the following portion of the bidding documents shall now be read as follows:

I. AMENDMENTS

1. SECTION I: INVITATION TO BID

AMENDMENT/CLARIFICATION		JUSTIFICATION/ EXPLANATION
SCHEDULE OF ACTIVITIES:		To correct the typographical error of the requirements.
Activity	Date and Time	
Deadline for submission of bids	May 10, 2019; 1:30PM May 17, 2019; 10:00 AM	
Opening of Bids	Immediately after the Deadline of Submission of Bids	

	Reference		Bases for Amendment/s
	From	To	
Page 4	1. The PROCUREMENT SERVICE invites PhilGEPS registered suppliers to bid for the following items: xxx Lot 4: Item 2: 18,845 books – Grade 8 Esp TX	1. The PROCUREMENT SERVICE invites PhilGEPS registered suppliers to bid for the following items: xxx Lot 4: Item 2: 18,845 books – Grade 8 Esp TX TM	To correct the typographical error of the requirements.

2. SECTION III: BID DATA SHEET

Clause	Reference		Bases for Amendment/s
	From	To	
ITB Clauses 1.6; 2; 13.2; 28.3	xxx Lot 4: Item 2: 18,845 books – Grade 8 Esp TX	xxx Lot 4: Item 2: 18,845 books – Grade 8 Esp TX TM	To correct the typographical error of the requirements.

¹ For the purpose of this Bulletin and for the Procurement Service, the following symbols shall be used: **XXX** – denotes inclusion or new item/requirement; ~~XXX~~ – denotes deletion of item/requirement; **XXX** – denotes inclusion or new item/requirement; ~~XXX~~ – denotes deletion of item/requirement; **XXX** – denotes inclusion or new item/requirement; ~~XXX~~ – denotes deletion of item/requirement.



18.1	The bid security shall be in the form of a Bid Securing Declaration, or any of the following forms and amounts: Xxx Lot 1: Grade 8 Mathematics TX & TM 2% is 3,641,646.84; and 5% is 9,104,117.10	The bid security shall be in the form of a Bid Securing Declaration, or any of the following forms and amounts: Xxx Lot 1: Grade 8 Mathematics TX & TM 2% is 3,641,646.84 <u>3,676,321.64</u> ; and 5% is 9,104,117.10 <u>9,190,804.1</u>	To correct the typographical error of the requirements.
------	-----------------------------------------------------------------------------------------------------------------------------------------------------------------------------------------------------------------------	----------------------------------------------------------------------------------------------------------------------------------------------------------------------------------------------------------------------------------------------------------------------------------------	---------------------------------------------------------

3. SECTION V: SPECIAL CONDITIONS OF CONTRACT

GCC Clause	Reference		Bases for Amendment/s
	From	To	
1.1 (j)	xxx Lot 4: Item 2: 18,845 books – Grade 8 Esp TX	xxx Lot 4: Item 2: 18,845 books – Grade 8 Esp TX <u>TM</u>	To correct the typographical error of the requirements.

4. SECTION VII: TECHNICAL SPECIFICATIONS

	Reference		Bases for Amendment/s
	From	To	
Page 79	Lot 2: Printing, Supply and Delivery of Grade 8 Filipino Learning Resources xxx Grade 8 Mathematics Learning Resources , complies with the following minimum requirements unless specified:	Lot 2: Printing, Supply and Delivery of Grade 8 Filipino Learning Resources xxx Grade 8 Mathematics Filipino Learning Resources , complies with the following minimum requirements unless specified:	To correct the typographical error of the requirements.
Page 81	Lot 3: Printing, Supply and Delivery of Grade 8 English Learning Resources Total Approved Budget for the Contract: P 178,536,099.00 xxx	Lot 3: Printing, Supply and Delivery of Grade 8 English Learning Resources Total Approved Budget for the Contract: P 178,536,099.00 <u>P176,675,598.00</u> xxx	To correct the typographical error of the requirements.

Page 83	Lot 4: Printing, Supply and Delivery of Grade 8 EsP Learning Resources xxx Item No. 2: EsP TX	Lot 4: Printing, Supply and Delivery of Grade 8 EsP Learning Resources xxx Item No. 2: EsP TX <u>TM</u>	To correct the typographical error of the requirements.
Note: Refer to Appendix 1 & 2 for the revised Schedule of Delivery (Section VI) and Technical Specifications (Section VII)			

5. SECTION VIII: BID FORMS

-	Reference		Bases for Amendment/s
	From	To	
Page 89	Lot 4: Printing, Supply and Delivery of Grade 8 EsP Learning Resources xxx Item No. 2: EsP TX	Lot 4: Printing, Supply and Delivery of Grade 8 EsP Learning Resources xxx Item No. 2: EsP TX <u>TM</u>	To correct the typographical error of the requirements.
Note: Refer to Appendix 3 for the revised Bid Form "Annex"			

All other portions of the Bidding Documents affected by these amendments shall be made to conform to the same.

Amendments/inclusions/clarifications made herein shall be considered an integral part of the Bidding Documents.

The changes made in the Philippine Bidding Documents (5th Edition, October 2016) are deemed integrated in the terms and conditions for this project.

ENGR. MANUEL S. AVILA
 Chairperson, BAC II

Schedule of Requirements

Lot No.	Item No.	Qty	Item/Description
1	1	1,785,121 books	Grade 8 Mathematics TX
	2	18,845 books	Grade 8 Mathematics TM
2	1	1,785,121 books	Grade 8 Filipino TX
	2	18,845 books	Grade 8 Filipino TM
3	1	1,785,121 books	Grade 8 English TX
	2	18,845 books	Grade 8 English TM
4	1	1,785,121 books	Grade 8 EsP TX
	2	18,845 books	Grade 8 EsP TM

- **Press Proofing and approval by the DepEd within Fifteen (15) Calendar Days upon receipt of Notice to Proceed.**
- **The mass production and delivery to Central Office Warehouse and Public High School Nationwide shall reckoned upon issuance of “Certificate of Mass Printing” issued by DepED within One Hundred Fifty Calendar Days (150CD). *(Soft Copy of Distribution List in excel format will be given to the awarded bidder for easy reference together with the digital file of the learning resources to be printed.***

Note:

1. The mentioned Learning Resources shall be provided by the End-user Agency with CD/DVD (cover and inside pages) in pdf file.

I hereby commit to comply and deliver all the above requirements in accordance with the above stated schedule.

Name of Company	Signature Over Printed Name of Authorized Representative	Date
-----------------	-------------------------------------------------------------	------

TECHNICAL SPECIFICATIONS

Lot 1 : Printing, Supply and Delivery of Grade 8 Mathematics Learning Resources

Total Approved Budget for the Contract : P 183,816,082.00

Item No.	Item/Description	No. of Pages excluding Cover	Quantity
1	Mathematics TX	472	1,785,121 books
2	Mathematics TM	264	18,845 books
Total Quantity:			1,803,966 books

AGENCY SPECIFICATIONS	BIDDER'S STATEMENT OF COMPLIANCE
Grade 8 Mathematics Learning Resources , complies with the following minimum requirements unless specified:	
Book Size: 8.25" x 10.75"	
Paper Requirement:	
a. Cover	
- Foldcote Cal. #12	
- Solid White	
- Basis Weight: 230gsm (-5%)	
b. Inside Pages	
- Uncoated Paper (white)	
- Basis Weight: 70gsm (-5%)	
- Brightness: 80% (-3%)	
- Opacity: 90% (-5%)	
Colors:	
a. Cover: 4/1 colors with UV coating	
b. Inside Pages: 1 color	
Binding: Perfect Binding	
TECHNICAL SPECIFICATIONS FOR PACKAGING MATERIALS AND PROPOSED PACKAGING DETAILS	
BOX	
The box materials shall have these specifications:	
1. Corrugation: B or C (Single Wall) flute	
2. Burst Strength: 175 psi -2% tolerance	
3. Joint: Taped with 50.8 mm wide packaging tapes or better	
4. Approximate Length: 43.5 cm	
5. Approximate Width: 28.5 cm	
For box with overlap joints, the overlap joint shall be fixed by high grade glue and its outside joint shall be reinforced by a 50.8 mm packaging tape or better. Tin/staple wires shall not be used to reinforce the joints.	

PACKAGING TAPE	
50.8mm or 2 inches wide packaging tape	
PLASTIC STRAP	
12.7 mm wide plastic strap	
PROPOSE PACKAGING DETAILS	
The Learning Resources (LRs) shall be packed based on the attached allocation / packaging list per recipient and placed in unused corrugated box and seals to withstand rough handling.	
Each box shall contain the intended allocation, wrapped and sealed in plain plastic for adequate protection against moisture and water damage.	
For loose sets, LR's shall be wrapped in plastic or brown kraft paper. Package must be secured by packaging tape or better.	
Box shall be reinforced with at least 12.7 mm wide plastic strap with tin or other appropriate seal.	
Each box shall be properly labeled to indicate the following:	
Title, Quantity, Purchaser's Name and Address, Supplier's Name, Destination, DepEd logo (with flame), International Symbol, Linear Specifications, Volume, and Gross Weight.	
The maximum weight per box should not be more than 20 kilos.	
Please see sample illustration of proposed packaging:	

I hereby certify that the statement of compliance to the foregoing technical specifications are true and correct, otherwise, if found to be false either during bid evaluation or post-qualification, the same shall give rise to automatic disqualification of our bid.

Name of Company	Signature Over Printed Name of Authorized Representative	Date
-----------------	-------------------------------------------------------------	------

Lot 2 : Printing, Supply and Delivery of Grade 8 Filipino Learning Resources

Total Approved Budget for the Contract : P 178,536,099.00

Item No.	Item/Description	No. of Pages excluding Cover	Quantity
1	Filipino TX	352	1,785,121 books
2	Filipino TM	264	18,845 books
Total Quantity:			1,803,966 books

AGENCY SPECIFICATIONS	BIDDER'S STATEMENT OF COMPLIANCE
Grade 8 Filipino Learning Resources , complies with the following minimum requirements unless specified:	
Book Size: 8.25" x 10.75"	
Paper Requirement:	
a. Cover	
- Foldcote Cal. #12	
- Solid White	
- Basis Weight: 230gsm (-5%)	
b. Inside Pages	
- Uncoated Paper (white)	
- Basis Weight: 70gsm (-5%)	
- Brightness: 80% (-3%)	
- Opacity: 90% (-5%)	
Colors:	
a. Cover: 4/1 colors with UV coating	
b. Inside Pages: 1 color	
Binding: Perfect Binding	
TECHNICAL SPECIFICATIONS FOR PACKAGING MATERIALS AND PROPOSED PACKAGING DETAILS	
BOX	
The box materials shall have these specifications:	
1. Corrugation: B or C (Single Wall) flute	
2. Burst Strength: 175 psi -2% tolerance	
3. Joint: Taped with 50.8 mm wide packaging tapes or better	
4. Approximate Length: 43.5 cm	
5. Approximate Width: 28.5 cm	
For box with overlap joints, the overlap joint shall be fixed by high grade glue and its outside joint shall be reinforced by a 50.8 mm packaging tape or better. Tin/staple wires shall not be used to reinforce the joints.	
PACKAGING TAPE	
50.8mm or 2 inches wide packaging tape	
PLASTIC STRAP	

L'

12.7 mm wide plastic strap	
PROPOSE PACKAGING DETAILS	
The Learning Resources (LRs) shall be packed based on the attached allocation / packaging list per recipient and placed in unused corrugated box and seals to withstand rough handling.	
Each box shall contain the intended allocation, wrapped and sealed in plain plastic for adequate protection against moisture and water damage.	
For loose sets, LRs shall be wrapped in plastic or brown kraft paper. Package must be secured by packaging tape or better.	
Box shall be reinforced with at least 12.7 mm wide plastic strap with tin or other appropriate seal.	
Each box shall be properly labeled to indicate the following:	
Title, Quantity, Purchaser's Name and Address, Supplier's Name, Destination, DepEd logo (with flame), International Symbol, Linear Specifications, Volume, and Gross Weight.	
The maximum weight per box should not be more than 20 kilos.	
Please see sample illustration of proposed packaging:	

I hereby certify that the statement of compliance to the foregoing technical specifications are true and correct, otherwise, if found to be false either during bid evaluation or post-qualification, the same shall give rise to automatic disqualification of our bid.

Name of Company	Signature Over Printed Name of Authorized Representative	Date
-----------------	-------------------------------------------------------------	------

Lot 3 : Printing, Supply and Delivery of Grade 8 English Learning Resources

Total Approved Budget for the Contract : P 176,675,598.00

Item No.	Item/Description	No. of Pages excluding Cover	Quantity
1	English TX	384	1,785,121 books
2	English TM	264	18,845 books
Total Quantity:			1,803,966 books

AGENCY SPECIFICATIONS	BIDDER'S STATEMENT OF COMPLIANCE
Grade 8 English Learning Resources , complies with the following minimum requirements unless specified:	
Book Size: 8.25" x 10.75"	
Paper Requirement:	
a. Cover	
- Foldcote Cal. #12	
- Solid White	
- Basis Weight: 230gsm (-5%)	
b. Inside Pages	
- Uncoated Paper (white)	
- Basis Weight: 70gsm (-5%)	
- Brightness: 80% (-3%)	
- Opacity: 90% (-5%)	
Colors:	
a. Cover: 4/1 colors with UV coating	
b. Inside Pages: 1 color	
Binding: Perfect Binding	
TECHNICAL SPECIFICATIONS FOR PACKAGING MATERIALS AND PROPOSED PACKAGING DETAILS	
BOX	
The box materials shall have these specifications:	
1. Corrugation: B or C (Single Wall) flute	
2. Burst Strength: 175 psi -2% tolerance	
3. Joint: Taped with 50.8 mm wide packaging tapes or better	
4. Approximate Length: 43.5 cm	
5. Approximate Width: 28.5 cm	
For box with overlap joints, the overlap joint shall be fixed by high grade glue and its outside joint shall be reinforced by a 50.8 mm packaging tape or better. Tin/staple wires shall not be used to reinforce the joints.	
PACKAGING TAPE	
50.8mm or 2 inches wide packaging tape	
PLASTIC STRAP	

12.7 mm wide plastic strap	
PROPOSE PACKAGING DETAILS	
The Learning Resources (LRs) shall be packed based on the attached allocation / packaging list per recipient and placed in unused corrugated box and seals to withstand rough handling.	
Each box shall contain the intended allocation, wrapped and sealed in plain plastic for adequate protection against moisture and water damage.	
For loose sets, LRs shall be wrapped in plastic or brown kraft paper. Package must be secured by packaging tape or better.	
Box shall be reinforced with at least 12.7 mm wide plastic strap with tin or other appropriate seal.	
Each box shall be properly labeled to indicate the following:	
Title, Quantity, Purchaser's Name and Address, Supplier's Name, Destination, DepEd logo (with flame), International Symbol, Linear Specifications, Volume, and Gross Weight.	
The maximum weight per box should not be more than 20 kilos.	
Please see sample illustration of proposed packaging:	

I hereby certify that the statement of compliance to the foregoing technical specifications are true and correct, otherwise, if found to be false either during bid evaluation or post-qualification, the same shall give rise to automatic disqualification of our bid.

Name of Company Signature Over Printed Name
of Authorized Representative Date

Lot 4 : Printing, Supply and Delivery of Grade 8 EsP Learning Resources

Total Approved Budget for the Contract : P 176,656,753.00

Item No.	Item/Description	No. of Pages excluding Cover	Quantity
1	EsP TX	312	1,785,121 books
2	EsP TM	232	18,845 books
Total Quantity:			1,803,966 books

AGENCY SPECIFICATIONS	BIDDER'S STATEMENT OF COMPLIANCE
Grade 8 EsP Learning Resources , complies with the following minimum requirements unless specified:	
Book Size: 8.25" x 10.75"	
Paper Requirement:	
a. Cover	
- Foldcote Cal. #12	
- Solid White	
- Basis Weight: 230gsm (-5%)	
b. Inside Pages	
- Uncoated Paper (white)	
- Basis Weight: 70gsm (-5%)	
- Brightness: 80% (-3%)	
- Opacity: 90% (-5%)	
Colors:	
a. Cover: 4/1 colors with UV coating	
b. Inside Pages: 1 color	
Binding: Perfect Binding	
TECHNICAL SPECIFICATIONS FOR PACKAGING MATERIALS AND PROPOSED PACKAGING DETAILS	
BOX	
The box materials shall have these specifications:	
1. Corrugation: B or C (Single Wall) flute	
2. Burst Strength: 175 psi -2% tolerance	
3. Joint: Taped with 50.8 mm wide packaging tapes or better	
4. Approximate Length: 43.5 cm	
5. Approximate Width: 28.5 cm	
For box with overlap joints, the overlap joint shall be fixed by high grade glue and its outside joint shall be reinforced by a 50.8 mm packaging tape or better. Tin/staple wires shall not be used to reinforce the joints.	
PACKAGING TAPE	
50.8mm or 2 inches wide packaging tape	
PLASTIC STRAP	
12.7 mm wide plastic strap	
PROPOSE PACKAGING DETAILS	

The Learning Resources (LRs) shall be packed based on the attached allocation / packaging list per recipient and placed in unused corrugated box and seals to withstand rough handling.	
Each box shall contain the intended allocation, wrapped and sealed in plain plastic for adequate protection against moisture and water damage.	
For loose sets, LR's shall be wrapped in plastic or brown kraft paper. Package must be secured by packaging tape or better.	
Box shall be reinforced with at least 12.7 mm wide plastic strap with tin or other appropriate seal.	
Each box shall be properly labeled to indicate the following:	
Title, Quantity, Purchaser's Name and Address, Supplier's Name, Destination, DepEd logo (with flame), International Symbol, Linear Specifications, Volume, and Gross Weight.	
The maximum weight per box should not be more than 20 kilos.	
Please see sample illustration of proposed packaging:	

I hereby certify that the statement of compliance to the foregoing technical specifications are true and correct, otherwise, if found to be false either during bid evaluation or post-qualification, the same shall give rise to automatic disqualification of our bid.

Name of Company	Signature Over Printed Name of Authorized Representative	Date
-----------------	-------------------------------------------------------------	------

PACKAGE SPECIFICATIONS

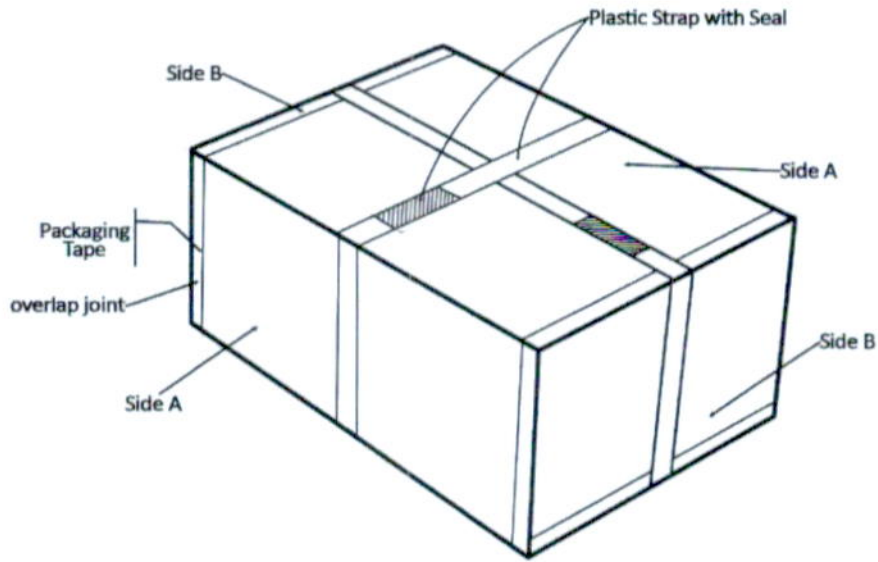

PERSPECTIVE

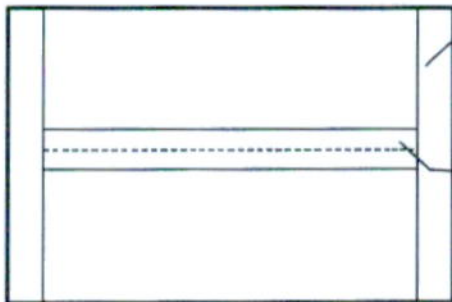

OUTSIDE BOTTOM VIEW

Packaging Tape

Packaging Tape

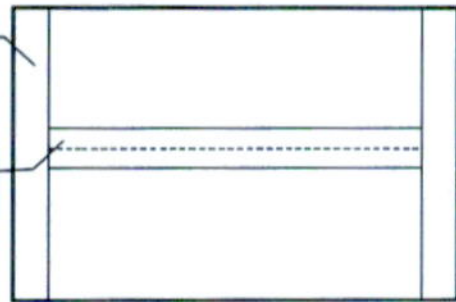

OUTSIDE TOP VIEW

Bid Form

Date: _____

Invitation to Bid No.: **Public Bidding No. 19-140-2**

To: *The DBM-PS BAC Chairman
Procurement Service
PS Complex, RR Road
Cristobal St., Paco, Manila*

Gentlemen and/or Ladies:

Having examined the Bidding Documents including Bid Bulletin Numbers [____], the receipt of which is hereby duly acknowledged, we, the undersigned, offer to **Supply, Print and Deliver Learning Resources for the Department of Education (DEPED)**, in conformity with the said Bidding Documents.

Lot No.	Item No.	Qty	Item/ Description	Amount per book	Freight Cost	Total Amount per book
1	1	1,785,121 books	Mathematics TX			
	2	18,845 books	Mathematics TM			
	TOTAL AMOUNT PER LOT					

TOTAL LOT PRICE IN WORDS:

Lot 1: _____

Lot No.	Item No.	Qty	Item/ Description	Amount per book	Freight Cost	Total Amount per book
2	1	1,785,121 books	Filipino TX			
	2	18,845 books	Filipino TM			
	TOTAL AMOUNT PER LOT					

TOTAL LOT PRICE IN WORDS:

Lot 2: _____

Lot No.	Item No.	Qty	Item/ Description	Amount per book	Freight Cost	Total Amount per book
3	1	1,785,121 books	English TX			
	2	18,845 books	English TM			
	TOTAL AMOUNT PER LOT					

TOTAL LOT PRICE IN WORDS:

Lot 3: _____

Lot No.	Item No.	Qty	Item/ Description	Amount per book	Freight Cost	Total Amount per book
4	1	1,785,121 books	EsP TX			
	2	18,845 books	EsP TM			
	TOTAL AMOUNT PER LOT					

TOTAL LOT PRICE IN WORDS:

Lot 4: _____

We undertake, if our Bid is accepted, to deliver the goods in accordance with the delivery schedule specified in the Section VI. Schedule of Requirements.

If our Bid is accepted, we undertake to provide a performance security in the form, amounts, and within the times specified in the Bidding Documents.

We agree to abide by this Bid for the Bid Validity Period specified in **BDS** provision for **ITB** Clause 18.2 **Error! Reference source not found.** and it shall remain binding upon us and may be accepted at any time before the expiration of that period.

Until a formal Contract is prepared and executed, this Bid, together with your written acceptance thereof and your Notice of Award, shall be binding upon us.

We understand that you are not bound to accept the Lowest Calculated Bid or any Bid you may receive.

We certify/confirm that we comply with the eligibility requirements as per **ITB** Clause 5 of the Bidding Documents.

R

We likewise certify/confirm that the undersigned, *[for sole proprietorships, insert: as the owner and sole proprietor or authorized representative of Name of Bidder, has the full power and authority to participate, submit the bid, and to sign and execute the ensuing contract, on the latter's behalf for the Printing, Supply and Delivery of Grade 8 Learning Resources for the Department of Education.*

Or;

[for partnerships, corporations, cooperatives, or joint ventures, insert: is granted full power and authority by the Name of Bidder, to participate, submit the bid, and to sign and execute the ensuing contract on the latter's behalf for Printing, Supply and Delivery of Grade 8 Learning Resources for the Department of Education.

² We acknowledge that failure to sign each and every page of this Bid Form, including the attached Schedule of Prices, shall be a ground for the rejection of our bid.

Dated this _____ day of _____ 20_____.

[signature]

[in the capacity of]

Duly authorized to sign Bid for and on behalf of _____

L