



Bid Bulletin No. 4
09 July 2021

Public Bidding No. 21-004-6

**Supply, Delivery and Installation of Furniture and Fixtures for the New NBI
Headquarters for the National Bureau of Investigation**

Issued pursuant to Sec. 22.5 of the IRR of R.A. 9184 to clarify and/or amend certain provisions in the Bidding Documents issued for this project, considering the issues raised and clarifications made by prospective bidders during the **Pre-bid Conference** held on **29 June 2021** likewise, respond to bidder's written queries received within the prescriptive period for filing.

A. AMENDMENTS/INCLUSIONS

Item No.	REFERENCE	BASES FOR AMENDMENT/INCLUSION
1.	<p>Section I: Invitation to Bid Page no. 9</p> <p>xxx 9. Bid opening shall be on 14 16 July 2021; 10:00 A.M. at PS Conference Room, Procurement Service, Cristobal St., Paco, Manila. The scheduled meeting may be accessed thru this link: https://meet.google.com/hme-yih-jtf http://meet.google.com/avq-uitm-tbw via Google Meet. Bids will be opened in the presence of the Bidders' representatives who choose to attend the activity(NTP)</p> <p>xxx</p>	<p><i>To revise the date and the Google Meet link as affected by the adjustment on the schedule.</i></p>
2.	<p>Section VI: Schedule of Requirements Page no. 29</p> <p>xxx Within Sixty (60) One Hundred Twenty (120) Calendar Days from the receipt date indicated in the Notice to Proceed (NTP).</p> <p>xxx</p>	<p><i>To amend the delivery period as approved by the End-User.</i></p> <p><i>(Please refer and use Appendix "1" for the amended form)</i></p>
3.	<p>Section VII: Technical Specifications</p> <p>Item no. 1 - Executive Table Detail Item no. 2 - Junior Executive Table Detail Item no. 14 - 2 Seater Sofa Chair</p>	<p><i>To include the detailed drawings for better understanding of the requirement.</i></p> <p><i>(Please refer to Appendix "2" for the inclusion)</i></p>

B. CLARIFICATION/S

Item No.	Reference	CONCERN / REQUEST	CLARIFICATION / RESOLUTION
During pre-bid conference			
1.	<p>5.3. Pursuant to Section 23.4.1.3 of the 2016 revised IRR of RA No. 9184, the Bidder shall have an SLCC that is at least one (1) contract similar to the Project the value of which, adjusted to current prices using the PSA's CPI, must be at least equivalent to:</p> <p>The Bidder must have completed a single contract that is similar to this Project, equivalent to at least fifty percent (50%) of the ABC.</p>	Prospective bidders clarified if aggregate contract allowed/acceptable for the SLCC?	<ul style="list-style-type: none"> <i>The requirement shall be retained.</i>
2.	<p>Section VI: Schedule of Requirements</p> <p>Within Sixty (60) Calendar Days from the receipt date indicated in the Notice to Proceed (NTP)</p>	Prospective bidders requested for extension of 90 to 120 calendar days	<ul style="list-style-type: none"> <i>Please refer to above amendments under the Schedule of Requirements.</i>
Diamond Office Furniture Inc.¹			
3.	ITB Clause 5.3 (page 13)	<p>1. For Single Largest Completed Contract, can we submit several Purchase Order to meet the 50% of ABC amounting to 47,197,982.52. For sample we have a project from one client but they issued several PO's for one project.</p>	<ul style="list-style-type: none"> <i>Please refer to clarification no. 1.</i>

¹ Letter received on 7/1/2021

4.	Section VII: Technical Specifications	2. For the chair requirements, can we offer a different design? Same specification, like leather and fabric color. If yes, can we add technical specification indicating our offered design?	<ul style="list-style-type: none"> • <i>No. The original specifications shall be retained.</i>
5.	Section I: Invitation to Bid	3. Do you have online payment for Bid Documents? Will you email or we will pick up the bidding documents once we paid?	<ul style="list-style-type: none"> • <i>Yes, we have. Bidding document will be provided by the BAC Secretariat upon showing of the Official Receipt as proof of payment.</i>
LBPI Design International²			
6.	Section VII: Technical Specifications	1. We would like to request for a detailed dimension of the compactor per line and/or layout of the compactor	<ul style="list-style-type: none"> • <i>Please refer to the Bidding Document page no. 39.</i>
7.		2. Can we offer cantilever chair instead of four-legged chair?	<ul style="list-style-type: none"> • <i>No. The original specifications shall be retained.</i>
8.		3. Can we offer other items that is similar to the pictures (not exactly the same)?	<ul style="list-style-type: none"> • <i>No. The original specifications shall be retained.</i>

² Letter received on 7/1/2021

Asiaprime Commodities Corp.³			
9.	Section VI: Schedule of Requirements	1. To extend the delivery date from 60 days to 120 days upon issuance of the NTP	<ul style="list-style-type: none"> • <i>Please refer to above amendments under the Schedule of Requirements.</i>
10.	ITB Clause 5.3 (page 13)	2. To use aggregated contract due to high ABC	<ul style="list-style-type: none"> • <i>Please refer to clarification no. 1.</i>

By Rules, all other related provisions in the Bidding Documents correspondingly affected by these amendments are likewise deemed amended to conform to this Bid Bulletin.

Amendments made herein shall be considered an integral part of the Bidding Document.

SIGNATURE REDACTED

WEBSTER M. LAUREÑANA

Chairperson, Special Bids and Awards Committee

For the purpose of this Bulletin and for better understanding of its contents, the following rules shall apply: (a) ~~Double Strike out~~ – denotes deletion; (b) Underline – denotes inclusion or new item/requirement; and “xxx” – denotes separation of phrase/s being amended from the rest of the main text

³ Letter received on 7/2/2021

Section VI. Schedule of Requirements

Lot No.	Qty	Item/Description	Delivery period
1	1 Lot	Supply, Delivery and Installation of Furniture and Fixtures for the New NBI Headquarters	<p>Within One Hundred Twenty (120) Calendar Days from the receipt date indicated in the Notice to Proceed (NTP)</p> <p>Note: Presence of the winning bidder's authorized representative is required during the delivery at the project site.</p>

I hereby commit to deliver the required quality and quantities upon receipt of the Purchase Order as indicated above.

Name of Company

Signature Over Printed
Name of Authorized
Representative

Date

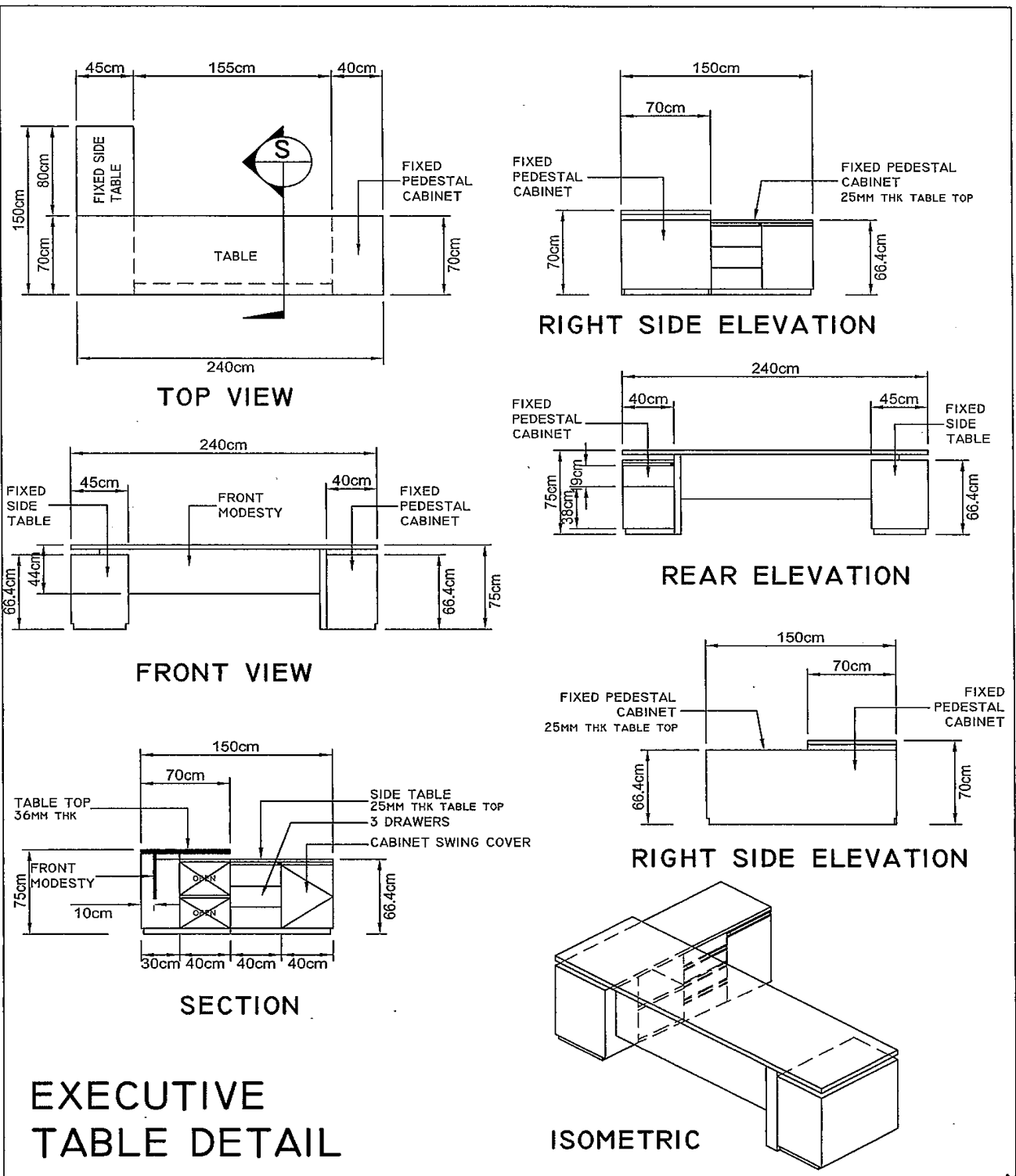

D

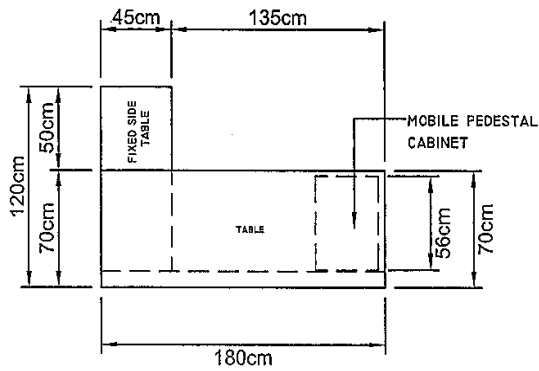

TOP VIEW

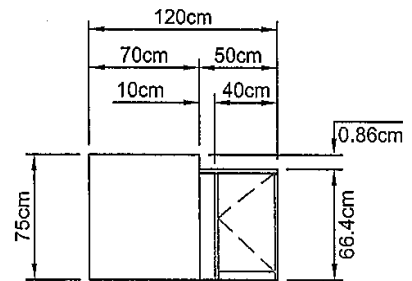

RIGHT SIDE ELEVATION

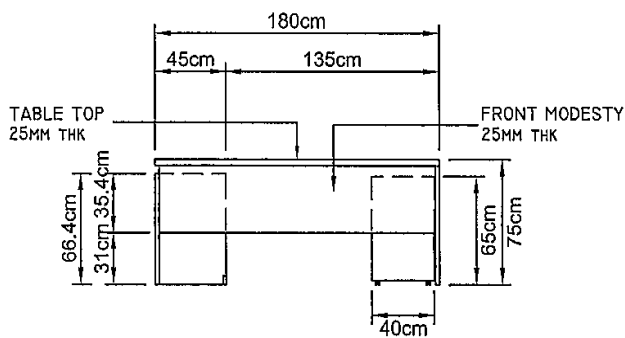

FRONT VIEW

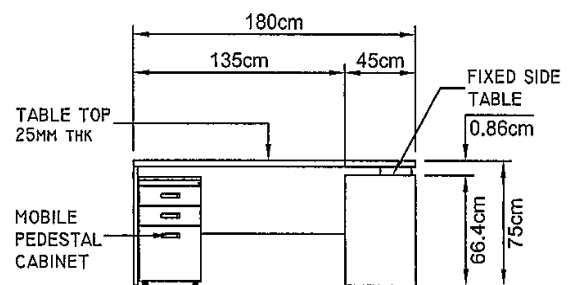

REAR VIEW

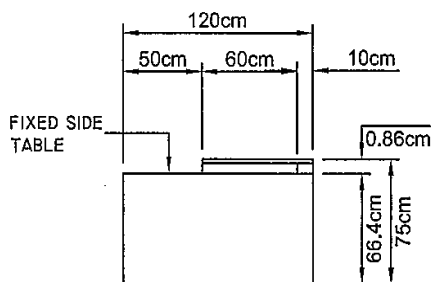

LEFT SIDE ELEVATION

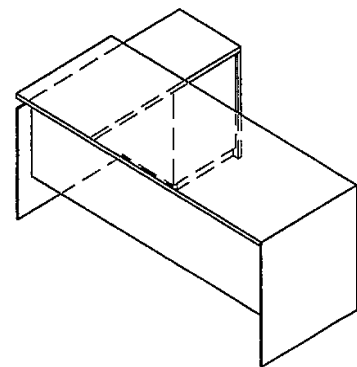

ISOMETRIC

JUNIOR EXECUTIVE TABLE DETAIL

Handwritten mark or signature.

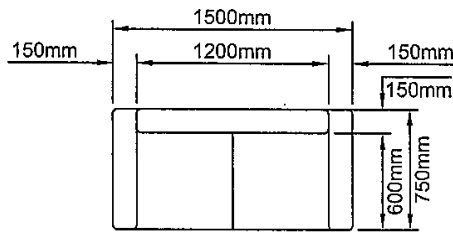

TOP VIEW

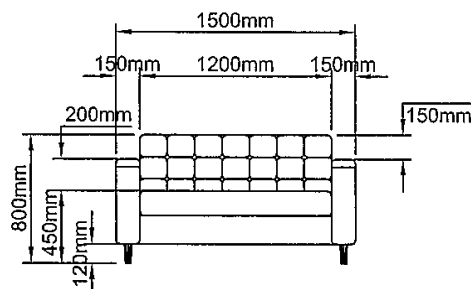

FRONT ELEVATION

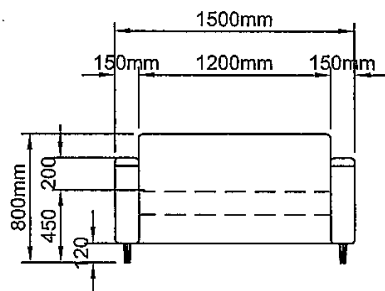

REAR ELEVATION

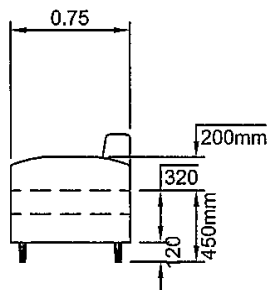

RIGHT SIDE ELEVATION

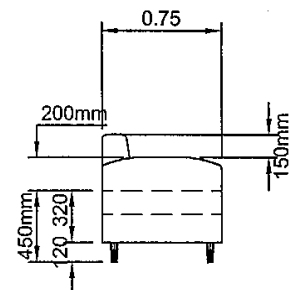

LEFT SIDE ELEVATION

2 SEATER
SOFA CHAIR