



Bid Bulletin No. 8
17 September 2021

PUBLIC BIDDING No. 21-119-5

SITE DEVELOPMENT OF 100-HECTARE AREA AT
BATAAN TECHNOLOGY PARK, MORONG, BATAAN

Issued pursuant to Sec. 22.5 of the IRR of R.A. 9184 to clarify and/or amend certain provisions in the Bidding Documents issued for this project, considering the issues raised and clarifications made by prospective bidders during the Pre-Bid Conference held on **13 August 2021**, likewise, respond to bidders' written queries received within the prescriptive period for filing.

A. AMENDMENTS/INCLUSIONS

I. SECTION IX. CHECKLIST OF TECHNICAL AND FINANCIAL DOCUMENTS

REFERENCE	BASIS FOR AMENDMENT/ INCLUSIONS
<p>Page 36</p> <p>Xxx</p> <p>(a) Valid PhilGEPS Registration Certificate (Platinum Membership) (all pages);</p> <p><i>or</i></p> <p>(b) <u>Certified True Copy</u> of Registration certificate from Securities and Exchange Commission (SEC), Department of Trade and Industry (DTI) for sole proprietorship, or Cooperative Development Authority (CDA) for cooperatives or its equivalent document; <i>and</i></p> <p>(c) <u>Certified True Copy</u> of Mayor's or Business permit issued by the city or municipality where the principal place of business of the prospective bidder is located, or the equivalent document for Exclusive Economic Zones or Areas; <i>and</i></p> <p>(e) <u>Certified True Copy</u> of Tax clearance per E.O. No. 398, s. 2005, as finally reviewed and approved by the Bureau of Internal Revenue (BIR).</p> <p>(h) <u>Certified True Copy</u> of Philippine Contractors Accreditation Board (PCAB) License; <i>or</i> Special PCAB License in case of Joint Ventures; <i>and</i> registration for the type and cost of the contract to be bid; <i>and</i></p> <p>XXX</p>	<p>The certified true copies of the following documents are required as issued by the appropriate government agencies:</p> <ol style="list-style-type: none"> 1. Business Permit 2. DTI/SEC Registration 3. Tax Clearance 4. PCAB License

B. CLARIFICATION

The Department of Budget and Management - Procurement Service, Bids and Awards Committee V hereby clarifies prospective bidders' concerns and queries:

ITEM	REFERENCE	CONCERN	CLARIFICATION/RESOLUTION
RHODIUM 688 BUILDERS, INC.¹			
1	Section IX. Checklist of Technical and Financial Document	1. If the contractors has a valid PHILGEPS Registration Certificate, do we need to secure a Certified True Copy of our DTI/SEC Registration, Business/Mayor's Permit, Tax Clearance and PCAB License?	<p>The Certified True Copies of the DTI/SEC Registration, Business/Mayor's Permit, and PCAB License may no longer be submitted during the Opening of Bids if the bidder submits a valid and updated PhilGEPS Registration Certificate including its Annex "A".</p> <p>However, in case the bidder is declared as the Lowest Calculated Bid (LCB), the Committee will require the bidder to submit the Certified True Copies within five (5) calendar days in order to determine the veracity of the submitted documents as part of the post-qualification.</p>
2	Section IX. Checklist of Technical and Financial Document	2. If the contractor has already secured a Certified True Copy of the documents, prior to the submission of bid, is there a validity or time limit (i.e. how many days / months before the bid submission)?	There is no time limit on the validity of the certified true copies of the documents provided that these should be latest, valid, and updated.
3	Section IX. Checklist of Technical and Financial Document	3. We are securing a Certified True Copy of Tax Clearance, and we were advised that BIR is no longer issuing such document due to some incidents that there are proponents who are submitting fake tax clearance. They advised that any Tax Clearance submitted can be verified via their portal if its legit. How do we proceed if this is the case?	<p>The Certified True Copy of Tax Clearance shall no longer be required during the submission of bids.</p> <p>This amends the requirement provided under Bid Bulletin No. 7.</p>

¹ Letter received on 14 September 2021 through email.

¹ Letter received on 14 September 2021 through email.

³ Letter received on 14 September 2021 through email.



STA. CLARA INTERNATIONAL²			
4	Section III. Bid Data Sheet	1. May we know the percentage of Value Added Tax to be used by the Bidders for common references? There are some cases like in DPWH they mentioned the %VAT to be applied sometimes only 7.5%.	Please use 12% VAT to be indicated in the Bid Form for the Detailed Cost Estimates under Annex "N" of the Bidding Documents.
5	Section IV. General Conditions of Contract	2. Please confirm that all the legwork requiring coordination, permanent power application in which Electric Cooperative will assess the Bill deposit, contracted capacity is by contractor. Payment for the Bill deposit or cash advance that Electric Cooperative may charge to customer is by Client.	All expenses to be incurred for the application of permits, licenses, and utilities shall be shouldered by the winning bidder until the issuance of the Certificate of Completion by the HoPE.
RCE GLOBAL CONSTRUCTION INC.³			
6	Bidding Forms	In view hereof, we would like to respectfully confirm and clarify the criteria in the Detailed Estimate portion; are we to fill the Detailed Estimate Form alone or we still need to attach the itemized breakdown of the Detailed Estimate?	The breakdown of the detailed cost estimates should not be attached.
ALMERIA INTERNATIONAL CONSTRUCTION CORPORATION.⁴			
7	Section VII. Drawings	Please clarify the following: Valve Box On drawing sheets P50-2 and P 29.1-2 shows a VALVE BOX with internal diameter of 3000 mm diameter and 1200 mm diameter but both are titled "VALVE BOX (100mm & LARGER)". We assumed that the 1200mm diameter is supposed to be "VALVE BOX (75 mm & SMALLER). Please confirm. 350 cu.m Cistern Tank	Valve Box Please refer to valve box details in drawing sheet no. P29.1-2, as shown on the snipped drawing below, for 100mm & LARGER valves: Valve Box for 100mm & LARGER

⁴ Letter received on 14 September 2021 through email.

⁵ Letter received on 9 September 2021 through email.

⁶ Letter received on 7 September 2021 through email.

⁷ Letter received on 14 August 2021 through email.

⁸ Letter received on 14 September 2021 through email.

On drawing sheet P 29. 1-1 shows the plan of 350 cu.m. Cistern Tank. The tank dimension is 10000mm x 15000mm. The tank piping have the following:

- a) 2 nos. x 150 mm diameter gate valve supply lines in a valve box on the right side.
- b) 2 nos. x 150 mm diameter gate valve supply lines and 2 nos. x 150 mm diameter gate valve distribution lines in a valve box on the left side, in total there 4 nos. valve box on the left side.

As shown, the valve box is not proportionally/scaled drawn either the smaller or larger valve box, Hence, please clarify which details to follow taking into consideration the dimension of the tank is 15m only but will have 4 nos. valve box to be constructed.

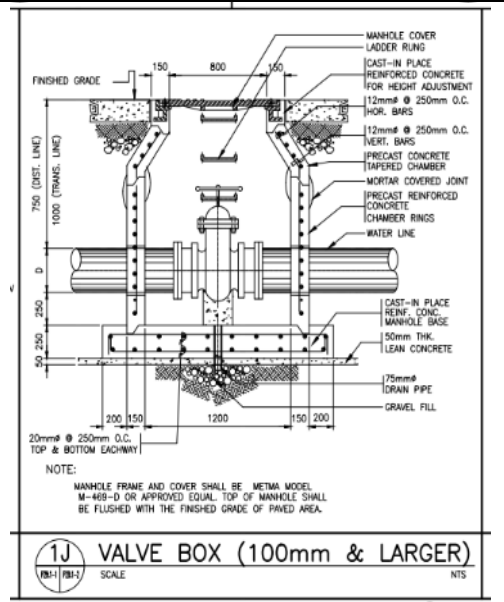

For 75 mm and SMALLER valves, please refer to the valve box details below:

Valve Box for 75mm & SMALLER

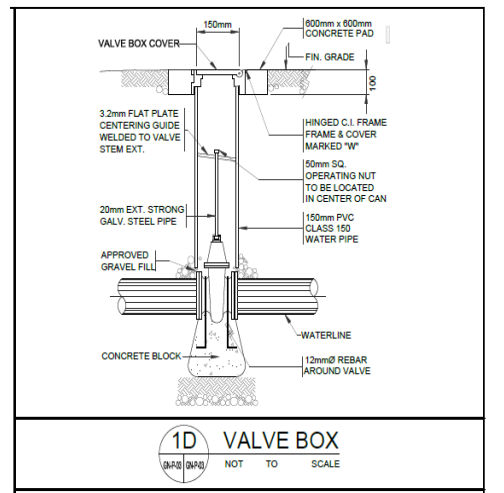

350 cu.m. Cistern Tank

- a. There are two (2) supply lines (from deep well source) with 150mm gate valves inside the valve box at the right side leading to the two compartments/chambers of the 350 cu.m. cistern tank.
- b. There are four (4) 150mm gate valves inside the valve box at the left side for the following:



			<ul style="list-style-type: none"> • Two (2) supply lines coming from Morong Water District leading to the two (2) chambers of Domestic Water Cistern. • Two (2) distribution lines coming from the Domestic Water Cistern to the Water Distribution System.
8	Section VII. Drawings	<p>We would like to clarify with regards to the following:</p> <p>At the Main Gate/ Alternate Entrance/ Exit Gate</p> <ol style="list-style-type: none"> 1. There are walk through metal detectors , 8 units in the drawing but are not included in the BOQ. 2. There are 32 car bar stopper in the drawing but not included in the BOQ. 	<ol style="list-style-type: none"> 1. The walkthrough metal detectors (8 units) will be implemented in the future packages and are not included under this project. 2. The 32 car bar stoppers will be implemented in the future packages and are not included under this project.

By Rule, all other related provisions in the Bidding Documents correspondingly affected by these amendments are likewise deemed amended to conform to this Bid Bulletin.

Amendments made herein shall be considered an integral part of the Bidding Documents.

JMS

JULIUS M. SANTOS

Chairperson, Bids and Awards Committee V

For the purpose of this Bulletin and for better understanding of its contents, the following rules shall apply: (a) Double Strike out – denotes deletion; (b) Underline – denotes inclusion or new item/requirement; and "xxx" – denotes separation of phrase/s being amended from the rest of the main text.