

BIDDING DOCUMENTS

FOR

PROCUREMENT OF

**PACKAGE CP NS-02: ROLLING STOCK -
COMMUTER TRAINSETS**

Volume II of III

PART 2 – EMPLOYER’S REQUIREMENTS

September 2020

Employer:	Department of Transportation
Procuring Agent:	Procurement Service
Country:	Republic of the Philippines
Project:	The Malolos-Clark Railway Project and the North-South Railway Project – South Line (Commuter)
JICA Loan No.:	PH-P270

(This page is intentionally left blank)

BIDDING DOCUMENTS

SUMMARY OF DOCUMENTS

Invitation for Bids (IFB)

Volume I. Part 1 – Bidding Procedures

- Section I. Instructions to Bidders (ITB)
- Section II. Bid Data Sheet (BDS)
- Section III. Evaluation and Qualification Criteria (EQC)
- Section IV. Bidding Forms (BF)
- Section V. Eligible Source Countries of Japanese ODA Loans (ESC)

Volume II. Part 2 – Employer’s Requirements

- Section VI. Employer’s Requirements
 - 1. Scope of Works (SOW)
 - 2. Specifications
 - A. General Requirements (ERG)
 - B. Technical Requirements (ERT)
- Section VII. Alignment Drawings

Volume III. Part 3 – Conditions of Contract and Contract Forms

- Section VIII. General Conditions (GC)
- Section IX. Particular Conditions (PC)
- Section X. Annex to the Particular Conditions-Contract Forms (CF)

(This page is intentionally left blank)

EMPLOYER’S REQUIREMENTS

1.	SCOPE OF WORK (SOW)	
1.1	General	SOW-1
1.2	Implementation Plan	SOW-1
1.3	Technical Design of Rolling Stock	SOW-1
1.4	Driver’s Cab and Saloon Mock-Up	SOW-2
1.5	Train Operation Simulator Parts	SOW-2
1.6	Manufacturing	SOW-2
1.7	Procurement of Materials, Components and Sub-Systems	SOW-2
1.8	Inspection, testing and Commissioning	SOW-2
1.9	Delivery of Rolling Stock to the Site	SOW-2
1.10	Provision for Spare Parts and Special Tools	SOW-2
1.11	Provision of Rolling Stock Operation and Maintenance (O&M) Manuals	SOW-3
1.12	Training for Employer’s Personnel	SOW-3
1.13	Providing “As-Built” Documentation	SOW-3
1.14	Providing Engineering Services During the Defect Notification Period	SOW-3
2.	SPECIFICATIONS	
A.	GENERAL REQUIREMENTS (ERG)	ERG-1
1.	General	ERG-1
2.	The Coordination and Integration of Electrical and Mechanical Equipment.	ERG-8
3.	Environmental Conditions and Environmental Plan	ERG-8
4.	Health and Safety	ERG-12
5.	Safety Considerations for Design	ERG-34
6.	Common Technical Requirements for All Equipment	ERG-35
7.	Quality Assurance	ERG-38
8.	System Assurance	ERG-48
9.	Contract Procedures	ERG-51
10.	Project Implementation	ERG-54
11.	Parts Lists, Special Tools and Test Equipment	ERG-65
12.	Inspection, Testing and Commissioning	ERG-67
13.	Operating and Maintenance Manuals and Drawings	ERG-69
14.	Training	ERG-71
15.	Equipment Identification	ERG-75
16.	Publicity and Public Relation	ERG-75
17.	(Not Used)	ERG-78
18.	Requirement Management	ERG-78
19.	Asset Management	ERG-79
20.	Interface Management	ERG-80
	Appendix A Definitions and Abbreviations	ERG-88
	Appendix B Split Responsibility for Rolling Stock and Other Works	ERG-95
	Appendix C (Not Used)	ERG-101
	Appendix D Work Programme Reference	ERG-102
B.	TECHNICAL REQUIREMENT (ERT)	
1.	System Requirements	ERT-1
2.	Car Body	ERT-26
3.	Bogies	ERT-31

4.	Coupler and Draft Gear	ERT-37
5.	Car Interior	ERT-39
6.	Lighting	ERT-50
7.	Doors and Door Control	ERT-52
8.	Ventilation and Air- Conditioning	ERT-57
9.	Brake System	ERT-60
10.	Pneumatic Equipment	ERT-65
11.	Propulsion System	ERT-67
12.	Primary Power System	ERT-73
13.	Auxiliary Electrical System	ERT-75
14.	Train Management System	ERT-79
15.	Communication System	ERT-83
16.	Signaling System Interface	ERT-89
17.	CCTV System	ERT-97
18.	(Not Used)	ERT-98
19.	General Documentation Requirements	ERT-99
20.	Inspection, Testing and Commissioning	ERT-105
21.	Material and Workmanship	ERT-114
22.	Project Management Requirements	ERT-119
23.	Quality Assurance Requirements	ERT-124
24.	Spare Parts and Special Tools	ERT-126
25.	Supply of Equipment for Training Center	ERT-133
26.	Asset Register	ERT-135
27.	Shipping and Delivery	ERT-136
Appendix A	Schematic Diagram of Basic Vehicle Configuration (for reference)	ERT-138
Appendix B	Schematic Diagram of Rolling Stock Gauge and Construction Gauge	ERT-139
Appendix C	Schematic Diagram of Vehicle (for reference)	ERT-140
Appendix D	Door Positions in The Car and Door Pitches	ERT-141
Appendix E	Tractive Effort Curve and Regenerative Effort Curve	ERT-142
Appendix F	Schematic diagram of model of control transmission system (for reference)	ERT-143
Appendix G	Schematic diagram of model of monitor transmission system (for reference)	ERT-144
Appendix H	Sample data of run-curve simulation for considering the capacity of Propulsion system (Station data for NSCR N1, N2 and SC)	ERT-145
Appendix I	Sample data of run-curve simulation for considering the capacity of Propulsion system (Speed Limit of NSCR N1, N2 and SC)	ERT-146
Appendix J	Sample data of run-curve simulation for considering the capacity of Propulsion system (Gradient for NSCR N1, N2 and SC)	ERT-153
Appendix K	Sample data of run-curve simulation for considering the capacity of Propulsion system (Curvature NSCR N1, N2 and SC)	ERT-160

3. ALIGNMENT DRAWINGS

SECTION VI. EMPLOYER’S REQUIREMENTS

(This page is intentionally left blank)

1. SCOPE OF WORKS (SOW)

(This page is intentionally left blank)

1 SCOPE OF WORKS (SOW)

The purpose of this document is to provide the Scope of Works (SOW) for the Contractor for the procurement of the Rolling Stock. A detailed description of the SOW is provided in the Bidding Documents, Part 2 Works Requirements, Section VI Employer’s Requirements which is subdivided into the General Requirements (ERG) and Technical Requirements (ERT). Should there be any discrepancies between the ERG and the ERT, the provisions specified in the ERT shall prevail.

1.1 General

The SOW of the Contractor is to provide a Rolling Stock fleet of thirty-eight (38) 8-car train sets, which comprise of a total of 304 vehicles.

The SOW includes the following:

- 1) Implementation planning for the provision of vehicles;
- 2) Technical design of vehicles;
- 3) Driver’s Cab and saloon Mock-Up;
- 4) Train Operation Simulator Parts;
- 5) Manufacturing;
- 6) Procurement of materials, components and subsystems;
- 7) Delivery of Rolling Stock and Simulator Parts to the Site;
- 8) Testing and Commissioning of the vehicles;
- 9) Provision for spare parts and special tools for the Rolling Stock maintenance;
- 10) Provision of Rolling Stock Operation and Maintenance (O&M) Manuals;
- 11) Training of personnel;
- 12) Providing “As-Built” documentation for the vehicles;
- 13) Providing engineering service during the Defects Notification Period (DNP); and
- 14) Providing forty-eight (48) couplers and delivering them to the CP NS-01 Contractor.

1.2 Implementation Plan

Project Management Plan;

- 1) Design and Development Plan;
- 2) Inspection, Testing and Commissioning Plan; and
- 3) Any other plans and documentation that is described within the ERG and ERT.

1.3 Technical Design of Rolling Stock

The Contractor shall undertake the technical design for the Rolling Stock. This technical design shall include, but not limited to:

- 1) Design interfaces;
- 2) Coordination with related systems to ensure that the trains shall meet the overall operating requirements; and
- 3) Technical and performance requirements in accordance with the ERT.

Design reviews shall be conducted at each stage of the design process as specified. The Contractor shall start procurement, manufacturing, construction and installation after the

outcome of the Engineer’s review.

1.4 Driver’s Cab and saloon Mock-Up

The Contractor shall provide a full size fully equipped driver’s and saloon cab mock-up for evaluation of the cab design as specified in Sub-Clause 1.2.7 of the ERT.

1.5 Train Operation Simulator Parts

The Contractor shall provide a Simulator parts as specified in Sub-Clause 25 of the ERT.

1.6 Manufacturing

The Contractor shall manufacture thirty-eight (38) 8-cars train sets, total of 304 vehicles. Manufacturing of the vehicles and equipment shall be carried out under accepted production and certified quality control processes to the JIS Q9001 or other equivalent standards.

1.7 Procurement of Materials, Components and Sub-Systems

The Contractor shall procure materials, components and sub-systems which are required for the Rolling Stock manufacturing. The materials to be used in the manufacturing shall be of high quality and comply with relevant international standards acceptable to the Engineer. All materials, components and sub-systems shall be procured from reputable suppliers which are ISO 9001 certified or working toward this certification.

1.8 Inspection, Testing and Commissioning

The Contractor shall test all vehicles to ensure compliance to the specified performances in the ERT. Tests are categorized into Factory Acceptance Test (FAT), Site Acceptance Test (SAT), Testing and Commissioning.

FAT shall be conducted at the manufacturer’s facility with SAT, Testing and Commissioning being conducted after delivery to the Site.

System Integration Test (SIT) shall be conducted together with Signaling, Telecommunications and other suppliers as a part of SAT and Testing and Commissioning.

1.9 Delivery of Rolling Stock to the Site

The Contractor shall deliver the completed Rolling Stock by whichever means necessary to the Site as designated by the Engineer to meet the requirements of the Project delivery schedules and shall unload the Rolling Stock at the specified location.

1.10 Provision for Spare Parts and Special Tools

Spare parts, consumables, special tools and diagnostic test equipment shall be provided by the Contractor for the maintenance of the Rolling Stock.

The Contractor shall submit a comprehensive list of recommended spare parts in accordance with the requirements specified in the ERG and ERT.

The Contractor shall also provide all special tools, such as diagnostic test equipment,

test benches, jigs, etc. that shall be necessary for the operations and maintenance of the Rolling Stock and associated equipment.

1.11 Provision of Rolling Stock Operation and Maintenance (O&M) Manuals

The Contractor shall provide fully illustrated Operation and Maintenance (O&M) Manuals complete with the following:

- 1) Drawings;
- 2) Diagrams;
- 3) Schematics; and
- 4) Spare parts catalogues.

The maintenance manual shall be categorized as follows:

- 1) Running maintenance requirements;
- 2) Scheduled maintenance requirements; and
- 3) Overhaul maintenance requirements.

1.12 Training for Employer’s Personnel

The Contractor shall provide operational and maintenance training to the operation and maintenance staff.

Training shall be categorized as follows:

- 1) Operation staff training;
- 2) Maintenance staff training; and
- 3) Engineering staff training

Training shall include provision of all required training materials and appropriate training venues.

1.13 Providing “As-Built” Documentation

The Contractor shall submit as-built documentation for the Rolling Stock and its associated equipment.

The Contractor shall submit an as-built specification which has been updated and modified from the original ERT, taking account of any changes.

All as-built documentation shall be supplied in both ‘hard’ and ‘soft’ copy format.

1.14 Providing Engineering Service During the Defects Notification Period

The Contractor shall provide technical support as specified by the Engineer/Employer during the Defects Notification Period (DNP).

(This page is intentionally left blank)

2. SPECIFICATION

A) GENERAL REQUIREMENTS (ERG)

(This page is intentionally left blank)

1 General

1.1 Introduction

1.1.1 This General Requirements covers the general aspects of the Works and the requirement of Bids and Contracts, viz., submittal requirements of Design and Drawings, Management Plans, Project Planning and Progress Monitoring, Site Management, Drawings Standards, and Contractor’s Obligations for health and safety, etc. for the Malolos-Clark Railway Project (MCRP) and North-South Railway Project – South Line (NSRP-South) Rolling Stock CP NS-02 Package. This General Requirements shall be read in conjunction with the Bidding Procedure (Part 1 of the Bidding Documents), Employer’s Requirements (Part 2 of the Bidding Documents), and Conditions of Contract and Contract Forms (Part 3 of the Bidding Documents). The abbreviations used in the Bidding Documents are given in Appendix A to these General Requirements.

1.1.2 Definition of the Location of MCRP and NSRP-South

1.1.2.1 MCRP operations cover approximately 52 km of service line with a total of 7 stations from Malolos to Clark and NSRP-South operation cover approximately 56 km of service line with a total of 20 stations from Calamba to Solis.

1.1.2.2 To link with the MCRP and NSRP-South operation, an integrated transport system is envisaged with seamless transfers, i.e. unified ticketing system allowing efficient movement between lines and more intermodal stations facilitating access between the different lines and road-based transport services.

1.1.2.3 The portion of the Project to be carried out under JICA ODA loan involves the procurement of thirty-eight (38) new trains comprising 304 vehicles in total.

1.1.3 Definition and Purpose of the Work

1.1.3.1 The Project is identified as a priority strategic transport investment for decongesting traffic and promoting growth of other urban centers outside Metro Manila. The government’s current strategy is to expand, integrate and increase the capacity of railway services.

1.1.4 Design and Technical Criteria

1.1.4.1 It shall be considered that the alignment of MCRP and NSRP-South in Manila is near the sea coast and runs through a relatively polluted air environment which may present a mildly corrosive atmosphere, in which all equipment shall continue to operate satisfactorily. The vehicle car body shall be designed to withstand the rigors of the Manila railroad environment for a period of 30 years, without major overhaul. The trains shall be designed and tested to meet the safety requirements and maintenance requirements. The design of the Rolling Stock shall be a modern state-of-the-art design that offers a smooth ride quality and fulfills all required environmental standards, particularly noise attenuation levels.

1.1.4.2 Design Deviation

1.1.4.2.1 Deviation from the specified requirements and standards may be permissible only under the following very strict conditions:

- a. That the deviation shall achieve equivalent or superior level of safety and performance to the specified standards;

- b. That the deviation does not delay the procurement of the established manufacturing schedule. The Contractor shall be responsible for appropriate technical justification and to obtain the approval of related competent authorities; and
- c. All design deviations shall be reviewed by the Engineer.

1.1.4.3 Criteria for Design Personnel

- 1.1.4.3.1 Design work shall be conducted by suitably qualified engineering personnel who possess experience in the type of works for the Project scope. The Contractor shall provide a well experienced and qualified design manager to undertake the required design works which is specified by Evaluation and Qualification Criteria in Bidding Document’s Part 1 Bidding Procedures.

1.2 Mobilization and Demobilization

1.2.1 Mobilization

- 1.2.1.1 Mobilization shall commence within 14 days after the date of issue of Notice to Proceed, or on the Commencement Date of Works, whichever is earlier. It shall consist of preparatory work and operations, mobilization of the design team and design activities, including but not necessarily limited to, those necessary for the movement of personnel, equipment, supplies, and incidentals to the work; for the establishment of offices, buildings and other facilities necessary to commence work on project. Mobilization shall include providing prerequisite submittals prior to starting work plus all plans and programs as laid down in the Bidding Documents (Refer to Section 10.2.2 Mobilization Program).

1.2.2 Demobilization

- 1.2.2.1 Demobilization shall be considered as complete when all of the Contractor’s equipment, materials, personnel or anything else belonging to the Contractor, that are not required for the Defects Notification Period, have been removed from the Project Site, and all the requirements of the Contract for issue of the Taking Over Certificate of the Works have been satisfied. Demobilization shall include providing all the required submittals prior to close out of the work.

1.3 Submittals and Substitutions

- 1.3.1 In the Contract Documents, the intent has been to specify the minimum acceptable quality of workmanship and materials defined by reference to recognized industry and national standards, manufacturer’s name and product, or description of required attributes and performance.
- 1.3.2 The Contractor shall ensure that the specified products are furnished and installed in accordance with design intent, procedures have been established for advanced submittal of design data and other requirements, and submit for review by the Engineer.
- 1.3.3 The Contractor shall make all submittals required by the Contract Documents, and revise and resubmit as necessary to ensure compliance with the specified requirements. Individual requirements for submittals are described in pertinent sections of this General Requirements and the Technical Requirements.
- 1.3.4 Unless otherwise specified elsewhere, the Contractor shall initially supply to the Engineer two copies of all drawings, specifications and other documents required for review of the Engineer. After review of the Engineer, the Contractor shall submit an

electronic and six (6) hard copies of the drawings given Notice of No Objection, specifications and other documents for the use of the Engineer.

1.3.5 Coordination of Submittals

1.3.5.1 Prior to each submittal, the Contractor shall carefully review and coordinate all aspects of each item being submitted. The Contractor will then verify that each item and the submittal for it conforms in all respects with the requirements of the Contract Documents. The Contractor’s signature on each submittal certifies that this coordination has been performed.

1.3.6 Certificates of Compliance

1.3.6.1 The Contractor shall certify that all materials used in the Works comply with all specified provisions thereof. Certification shall not be construed as relieving the Contractor from furnishing satisfactory materials if, after tests are performed on selected samples, the material is found not to meet the specified requirements.

1.3.6.2 The Contractor shall show on each certification the name and location of the work, name and address of Contractor, quantity and date or dates of shipment or delivery to which the certificate applies, and name of the manufacturing or fabricating company. Certification shall be in the form of letter or company-standard forms containing all required data. Certificates shall be signed by an authorized officer of the company.

1.3.6.3 In addition to the above information, all laboratory test reports submitted with certificates of compliance shall show the date or dates of testing, the specified requirements for which testing was performed, and results of the test or tests.

1.3.6.4 The Contractor shall submit to the Engineer all certificates of compliance for products and materials as part of the submittal procedure.

1.3.6.5 Any work performed by the Contractor prior to the review of the Engineer, or before drawings and specifications are submitted and given Notice of No Objection, shall be at the Contractor’s risk.

1.3.7 Submittal Schedule

1.3.7.1 The Contractor shall compile a complete and comprehensive schedule of all submittals anticipated to be made during progress of the Works. This schedule shall include a list of each type of item for which the Contractor’s drawings, shop drawings, certificates of compliance, materials samples, guarantees, or other types of submittals are required. Upon review by the Engineer, the Contractor shall be required to adhere to the schedule except when specifically, otherwise permitted.

1.3.7.2 The Contractor shall coordinate the schedule with all necessary sub-contractors and materials suppliers to ensure their understanding of the importance of adhering to the schedule given Notice of No Objection and their ability to so adhere. The Contractor shall revise and update the schedule on a monthly basis as necessary to reflect the current conditions and sequences and shall submit the same to the Engineer for review. The Contractor shall submit a recovery schedule in case of delay.

1.4 Standards and Codes

1.4.1 When a standard or code is referred to, it shall be assumed that the current revision, on the date of bid submission is applicable, unless otherwise stated. Where no standard is identifiable, the Contractor shall apply the equivalent JIS or other proven and equivalent

international standard.

1.5 Units

- 1.5.1 All drawings and design calculations submitted with the tender, or in accordance with the requirements of the Contract, shall use the International System of Units (SI Units).

1.6 Warranty

- 1.6.1 The Contractor shall be responsible for any defects or failures of equipment provided due to defective design, material or workmanship. Warranty will be provided for the full Defects Notification Period from the date of issue of the Taking Over Certificate and additional time required, if any, by the Contractor for rectification of defects.
- 1.6.2 The warranty/guarantee period for special tools, test equipment, maintenance and unit exchange spares shall be the full Defects Notification Period.
- 1.6.3 The repair and/or replacement of failed components and equipment and installation of repaired/replaced components/equipment shall be undertaken by the Contractor free of charge.
- 1.6.4 The Contractor shall bear customs duty, freight charges and all other expenses involved in the collection of defective components and equipment from the Site, and transportation to the manufacturer’s works abroad and its return to Site after repairs. Further, shall any design modification or rectification of defects or replacement of failed component or equipment be required to any component or equipment as a consequence of failure, the period of defects notification shall recommence from the date when the modified, rectified or replaced part is re-commissioned into service. The modifications (including any further modifications required during the revised Defects Notification Period) shall be carried out free of charge. Regardless of the above, the maximum Defects Notification Period is four (4) years from the date of issue of the Taking Over Certificate.
- 1.6.5 If there are any manufacturer’s warranties/guarantees for any equipment, continuing beyond the Defects Notification Period, the same shall be passed on to the Employer and in such cases the warranty/guarantee period of such equipment shall be as provided by the manufacturer.
- 1.6.6 All replacements and repairs under the warranty/guarantee shall be carried out by the Contractor promptly and satisfactorily on notification of the defects by the Engineer.

1.7 Management Plans and Program

- 1.7.1 In order to ensure satisfactory execution of the Contract, completion of Works within specified targets, and also to ensure quality in design, manufacturing and execution of work, a series of management plans shall be developed. The following plans and programs shall be developed and submitted by the Contractor for the Engineer’s review, taking into account the outline plans submitted for some of them, accompanying the Bid:
- a. Quality Management Plan (QMP);
 - b. Site Safety Management Plan (SSMP);
 - c. System Assurance Management Plan (SAMP);
 - d. Environmental Management Plan (EMP);
 - e. Project Management Plan (PMP);

- f. Interface Management Plan (IMP);
 - g. Inspection, Testing and Commissioning Plan (ITCP);
 - h. Detailed Works Program (Project Implementation Program);
 - i. System Integration Plan
 - j. Design Submission Program;
 - k. Requirements Management Plan (RMP); and
 - l. Training Plan.
- 1.7.2 The plans and documents shall be coordinated with each other and shall collectively define, describe and encompass the Contractor’s proposed methods, procedures, processes, organization, sequencing of activities to meet the requirements of the Technical Requirements (ERT) in respect of the subjects listed.

1.7.3 Quality Management Plan (QMP)

- 1.7.3.1 The Contractor shall submit within thirty-five (35) days from the Commencement Date of the Works a comprehensive Quality Management Plan describing the Quality Management System (QMS), which includes the Information Management Plan and electronic document management as per the requirements of Sub-Clauses 7.1, 7.7 & 7.9 of this document. The Contractor shall document and implement the Quality Management System that shall remain in effect during the execution of Works under the Contract.
- 1.7.3.2 The Contractor’s QMS shall be in compliance with JIS Q9000 for its scope of work and in compliance with the Contract. The Quality Management Plan shall include details to the quality assurance scheme and detailed QA/QC plans and documents to fully describe the system which shall operate from contract award through design, manufacturing, testing, approval, warranty and maintenance.

1.7.4 Site Safety Management Plan (SSMP)

- 1.7.4.1 The Contractor shall submit within forty-two (42) days from the Commencement Date of the Works, a comprehensive Site Safety Management Plan (SSMP) as per the requirements of Sub-Clause 4.4 of this document for the Engineer’s review, which shall include, but not limited to, to a site plan which contains details of the office, workplace and facilities on Site, a hazard analysis plan, fire control program, evacuation procedure, details of PPE, chain of reporting and all pertinent details to ensure hazards are rapidly identified and actions are taken to minimize risks to personnel, equipment & materials, together with detailing Methods of reporting and continuous improvement. The SSMP shall be in compliance with the Philippines’ Department of Labor and Employment (DOLE) Occupational Health and Safety (OH&S) standards and any other applicable local and international statutory regulations and requirements.

1.7.5 System Assurance Management Plan (SAMP)

- 1.7.5.1 The Contractor shall submit within forty-two (42) days from the Commencement Date of the Works, a comprehensive System Assurance Management Plan (SAMP) which contains all requirements as per Section 8 of this document, for the Engineer’s review.
- 1.7.5.2 The SAMP shall be certified by the Contractor’s internal department or by a third-party independent engineer. The SAMP shall be specifically developed for this Contract. The SAMP shall address the performance and safety of the Rolling Stock.

1.7.6 Environmental Management Plan (EMP)

1.7.6.1 The Contractor shall submit within forty-two (42) days from the Commencement Date of the Works a comprehensive Environmental Management Plan (EMP), as per the requirements of Sub-Clause 3.3 of this document, for the Engineer’s review. The Contractor shall describe how the different climatic aspects are dealt with, including noise, to ensure compliance.

1.7.7 Project Management Plan (PMP)

1.7.7.1 The Contractor shall submit within twenty-eight (28) days from the date of Commencement of the Works, a comprehensive Project Management Plan (PMP) as per the requirements of Sub-Clause 10.1.1 of this document.

1.7.8 Interface Management Plan (IMP)

1.7.8.1 The Contractor shall submit within forty-two (42) days from the Commencement Date of the Works, a comprehensive Interface Management Plan (IMP), as per the requirements of Sub-Clause 20.11 of this document, for the Engineer’s review.

1.7.9 Inspection, Testing and Commissioning Plan (ITCP)

1.7.9.1 The Contractor shall submit within ninety (90) days from the Commencement Date of the Works, a comprehensive Inspection, Testing & Commissioning Plan (ITCP), as per the requirements of Sub-Clause 12.2. The Contractor shall perform all necessary testing & commissioning activities in order to ensure satisfactory operation of the complete training system. The plan shall identify, inspection hold points, where work can only proceed after either review by Engineer or alternatively upon issuance of waiver of inspection by the Engineer.

1.7.10 Detailed Works Program (Project Implementation Program)

1.7.10.1 The Contractor shall submit within twenty-eight (28) days from the date of Commencement of the Works, a comprehensive Detailed Works Program (Project Implementation Program), as per the requirements of Sub-Clause 10.2.4 of this document for the Engineer’s review.

1.7.10.2 The Contractor shall revise the initial revised (baseline) detailed works program and resubmit at required intervals as required. The Contractor shall also show the mitigating initiatives to be employed to deal with any program slippage.

1.7.11 System Integration Plan

1.7.11.1 The Contractor shall submit within 42 days from the Commencement of the Works, a comprehensive System Integration Plan.

1.7.11.2 The Contractor shall provide a System Integration Plan for review by the Engineer. The System Integration Plan shall describe all the activities relating to:

- a. The preparation and validation of the detail interface requirement specifications with each of the interfacing contractors during the design stage.
- b. The delivery of the interfaces with each of the interfacing contractors according to the agreed detail interface requirement specifications.

- c. Validation of the delivered interfaces through the detail interface test plans.

1.7.12 Design Submission Program (DSP)

- 1.7.12.1 The Contractor shall submit within twenty-eight (28) days from the Commencement of the Works, a comprehensive Design Submission Program (DSP).
 1.7.12.2 The Contractor shall demonstrate that quality designs can be produced in the required timescale.

1.7.13 Requirements Management Plan (RMP)

- 1.7.13.1 The Contractor shall submit within twenty-eight (28) days from the date of Commencement of the Works, a comprehensive Requirements Management Plan including the plan for a Requirements Management Database, as per the requirements of Sub-Clause 18, for the Engineer’s review. The Contractor shall describe how requirements are compared from all multiple sources and how the Verification and Validation (V&V) process will be invoked.

1.7.14 Training Plan

- 1.7.14.1 The Contractor shall submit a Training Plan to the Engineer within twelve (12) months from the Commencement date as per the requirements of Sub-Clause 14.4.

1.7.15 Submittal Requirements of the Management Plans

- 1.7.15.1 The submittal requirements and the dates by which the management plans are to be submitted for the review of Engineer are summarized in Table 1.1 below.

Table 1.1 Management Plans

No.	Description	Reference	Submission from Commencement Date
		GC, ERG, ERT	
1	Quality Management Plan	ERG 1.7.3 & 7.1, ERT 23.1	35 days
2	Site Safety Management Plan	ERG 1.7.4 & 4.4	42 days
3	System Assurance Management Plan	ERG 1.7.5 & 8	42 days
4	Environmental Management Plan	GC 4.18, ERG 1.7.6 & 3.3	42 days
5	Project Management Plan	ERG 1.7.7, 10.1.1 & 16	28 days
6	Interface Management Plan	ERG 1.7.8, 2.3 & 20.11	42 days
7	Inspection, Testing and Commissioning Plan	ERG 1.7.9 & 12.2, ERT 20.2.2	90 days

No.	Description	Reference	Submission from Commencement Date
		GC, ERG, ERT	
8	Detailed Works Program (Project Implementation Program)	ERG 1.7.10 & 10.2.4, ERT 22.1	28 days
9	System Integration Plan	ERG 1.7.11	42 Days
10	Design Submission Program	ERG 1.7.12 & 10.2.3 ERT 1.2 & 22.3	28 days
11	Requirements Management Plan	ERG 1.7.13 & 18	28 days
12	Training Plan	ERG 1.7.14 & 14.4	12 months

2 The Coordination and Integration of Electrical and Mechanical Equipment

2.1 General

2.1.1 The Contractor shall ensure that all systems and subsystems are both physically and functionally compatible with each other, and shall work together to meet the requirements of the Technical Requirements.

2.2 Documentation Requirements

2.2.1 In order to ensure the requirements of Sub-Clause 2.1 of these General Requirements, information shall be presented via two formats, namely:

- a. The Interface Management Plan; and
- b. Drawings as referenced in Sub-Clause 13.

2.3 Interface Management Plan

2.3.1 Please refer to ERG 20.11 for the Interface Management Plan.

3 Environmental Conditions and Environmental Plan

3.1 General

3.1.1 The design of equipment shall take account of the climatic conditions and operating conditions as specified in this General Requirements and Technical Requirements, as appropriate.

3.1.2 All equipment shall be designed to perform in a satisfactory manner in the environment in which it is installed and to withstand the effects of high winds, temperature, humidity, vibration, noise, air and water pollution.

3.2 Climatic Conditions

3.2.1 The performance specification shall take into consideration the following environmental factors:

- a. Rainfall;
- b. Temperature range;
- c. Wind speeds;
- d. Topography;
- e. Geophysical conditions;
- f. Isokeraunic levels (lightning strikes); and
- g. Atmospheric pollution.

3.2.2 In addition, there are other adverse conditions that may be applicable to the area under consideration.

3.2.3 The general environmental conditions in the Manila area are as follows:

3.2.4 Rainfall

3.2.4.1 During the period from 1981 – 2010, Philippine Atmospheric Geographical and Astronomical Services Administration (PAGASA) stations in the vicinity of the Project area in Ninoy Aquino International Airport (NAIA) in Pasay City and Port Area Manila recorded an annual rainfall amount of 1,767.8 millimeters (mm), and 2,103.6 mm with a total of 101 and 139 rainy days, respectively.

3.2.4.2 Increase in rainfall is normally observed during the southwest monsoon season (June, July and August) until the transition month of September, October and November in most areas of Luzon. PAGASA’s climate projections in the Philippines showed varied trends in magnitude and direction of the rainfall strongly indicating increase in the effects of southwest and northeast monsoons.

3.2.4.3 Based on the Report of the weather bureau PAGASA on Climate Change in the Philippines in February 2011, the projected seasonal rainfall change shall generally show a reduction in rainfall in most parts of the country during the summer season (March, April, May), but shall also show as increase in rainfall during the southwest monsoon season (June, July, August) until the transition season (September, October, November) in most areas of Luzon and Visayas.

3.2.4.4 Simply, this means that the usual wet seasons are expected to become wetter and the dry seasons drier all over the country. In addition, extreme rainfall events (heavy daily rainfall) may continue to become more frequent. Extreme rainfall is projected to increase in Luzon and Visayas only in 2020 and 2050.

3.2.5 Temperature

3.2.5.1 The average normal annual temperature recorded at above mentioned PAGASA stations were 27.8 °C, and 28.4 °C, in NAIA Pasay City, and Port Area Manila, respectively. Based on climate trends from PAGASA using observed data during the period 1951 – 2010, there has been an increase in annual mean temperature by 0.648 °C or an average of 0.0108 °C per year increase. The warmest months are observed in April, May and June and the coldest months during December, January and February, with the temperature ranges of 28-30 °C and 25-27 °C.

3.2.6 Wind Speed and Direction

- 3.2.6.1 PAGASA weather stations recorded prevalent wind direction for the period 1981- 2010, as shown in Table 3.1. The average annual wind speed for NAIA, and Pasay City and Port Area, Manila are both 3 meters per second (mps).
- 3.2.6.2 Prevalent Wind Directions are indicated in the table below.

Table 3.1 Prevalent Wind Directions

Month	PAGASA Weather Stations	
	NAIA, Pasay City	Port Area, Manila
January to April	E	N, E, and SW
May to September	W	SW
October to December	E	SW and N
Annual	E	SW

Source: PAGASA

3.2.7 Humidity

- 3.2.7.1 The monthly relative humidity from PAGASA typically ranges from 66% to 84% over the course of the year. The average values for relative humidity were 76%, 74% and 78%, recorded at NAIA Pasay City, Port Area Manila and Science Garden Quezon City, respectively.

3.2.8 Air Quality

- 3.2.8.1 Monitoring data show particulate matter (PM) levels in Metro Manila that have exceeded the Air Quality Guideline Values set by the Philippine Government. Measures have been made to address the air quality problem in Metro Manila, but more needs to be done.
- 3.2.8.2 Most of the particulate matter collected from different sites around Metro Manila was attributed to traffic sources. Black Carbon is a major component of particulate matter samples collected in Metro Manila.

Month	Rainfall Data		Temperature						Relative Humidity (%)	Wind Direction/velocity	
	Amount (mm)	No. of Rainy Days	Max (°C)	Min (°C)	Mean (°C)	Dry Bulb (°C)	Wet Bulb (°C)	Dew Point (°C)		Wind Direction (16 pt)	Wind Velocity (m/s)
January	6.8	2	30.2	22	26.1	26	22.6	21.2	75	E	3
February	4.2	1	31	22.5	26.7	26.6	22.7	21.1	72	E	3
March	4	1	32.5	23.6	28	27.9	23.4	21.7	68	E	4
April	16	1	34.1	25	29.5	29.4	24.5	22.7	67	ESE	4
May	70.4	10	33.8	25.5	29.7	29.4	25.3	23.9	72	W	3
June	265.2	14	32.5	25.1	28.8	28.5	25.3	24.2	77	W	3
July	316.7	16	31.3	24.6	28	27.7	25.1	24.2	81	W	3
August	418.4	19	30.8	24.6	27.7	27.4	25.1	24.3	83	W	3
September	255.2	16	31	24.6	27.8	27.5	25.2	24.4	83	W	2
October	283.4	14	31.1	24.3	27.7	27.5	24.8	23.8	80	E	2
November	99	8	31.1	23.7	27.4	27.2	24.2	23.1	78	E	2
December	28.6	3	30.2	22.7	26.5	26.3	23.1	21.9	76	E	2
Annual	1767.8	101	31.6	24.0	27.8	27.6	24.3	23.0	76	E	3

Source: Climatological Normals at NAIA Synoptic Station, PAGASA (1981-2010)

Figure 3.1 Meteorological Data Recorded at NAIA Synoptic Station (1981-2010)

Month	Rainfall Data		Temperature						Relative Humidity (%)	Wind Direction/velocity	
	Amount (mm)	No. of Rainy Days	Max (°C)	Min (°C)	Mean (°C)	Dry Bulb (°C)	Wet Bulb (°C)	Dew Point (°C)		Wind Direction (16 pt)	Wind Velocity (m/s)
January	17.4	3	30.1	20.5	25.3	24.8	20.8	19.0	70	NW	3
February	18.6	3	31.0	20.7	25.9	25.4	21.1	19.2	68	ENE	3
March	28.4	4	32.6	21.8	27.2	26.8	22.0	20.0	66	NE	3
April	65	7	34.0	23.2	28.6	28.2	23.2	21.2	65	E	3
May	221.8	10	32.7	23.9	28.3	27.7	24.0	22.6	73	SE	2
June	241.2	18	31.5	23.6	27.6	27.0	24.3	23.3	80	S	3
July	422.6	22	30.6	23.5	27.0	26.3	24.2	23.4	84	S	3
August	429.4	24	30.1	23.5	26.8	26.0	24.2	23.5	86	S	2
September	293.1	21	30.5	23.2	26.9	26.0	24.0	23.2	85	S	2
October	177	12	31.1	23.0	27.0	26.5	23.6	22.5	78	NW	3
November	78	8	31.0	22.4	26.7	26.2	22.8	21.5	75	N	3
December	34.2	6	30.2	21.3	25.8	25.2	21.5	19.9	72	NW	3
Annual	2026.8	143	31.3	22.6	26.9	26.3	23.0	21.6	75	S	3

Source: Clark International Airport Station, PAGASA (1997-2010)

Figure 3.2 Meteorological Data at PAGASA CIA Synoptic Station (1997-2010)

- 3.2.8.3 Meteorological Data of the Philippines is indicated in figures above. These figures are merely indicative, and detailed values shall be obtained from the Philippine Meteorological Services.
- 3.2.8.4 The Contractor’s attention is drawn to the fact that because of solar load, track bed temperatures shall reach 55 °C and temperatures inside closed boxes shall reach 70°C. Because Manila is near the bay of the West Philippine Sea, the air is mildly corrosive atmosphere.
- 3.2.8.5 Manila having a dry climate for a considerable period of the year, the air frequently has high relative humidity aggravated by air pollutants (dust, etc.)

3.3 Environmental Management Plan (EMP)

- 3.3.1 Based on the outline Environmental Management Plan (EMP), the Contractor shall submit a detailed EMP illustrating the intended means of compliance with the Employer’s Requirements including noise standards for the cars 42 days after Commencement. The EMP shall state clearly the Contractor’s environmental objectives in detail and demonstrate the proposed method of achieving the environmental objectives with regard to the requirements of the Contract.

4 Health and Safety

4.1 Introduction

- 4.1.1 The Employer places particular emphasis on high standards of health and safety. The purpose of this section is to provide information on the requirements that shall apply to the Contractor.
- 4.1.2 In addition to the risks and hazards normally associated with construction works, the railway environment is particularly dangerous with for example, the risk of serious injury from electrocution or being struck by moving trains. Because of these hazards, the Employer has developed strict rules and operating procedures and associated training requirements with which all persons working on or about the MCRP and NSRP-South Line and the track must comply with in the interests of their own safety and the safety of others.
- 4.1.3 The Contractor shall point out in a timely manner to the Engineer the risks associated with both the basic assumptions of the Project and the technical requirements innate in the construction. The Contractor take into consideration when planning the Project, the general principles governing labor hazard prevention adapted to fit the Project, and in particular:
- a. Elimination of risks;
 - b. Addressing risks at their source;
 - c. Evaluation of risks that are unavoidable and propose preventive measures;
 - d. Description of the working method and of any required equipment, wherever this is deemed to be necessary due to high risk during construction, raling the train, testing, adjusting or repairing;
 - e. Replacement of hazardous materials for less hazardous ones;
 - f. Priority in decision-making concerning group protection in relation to the individual protection measures;
 - g. Adjustment to technical developments; and
 - h. Projection of the performance duration of those varied works or work phases.
- 4.1.4 The planning of an administration system meant to prevent labor hazards where the various roles and duties of the project administration staff are to be mentioned, as well as the special institutions for the prevention of professional hazard (safety engineer, safety and health at work coordinator, labor doctor, committee for the safety and health of people at work) provided by law. Also incorporated therein must be the basic safety and health procedures at work (e.g. report of labor accidents, emergencies, (use of explosives), (deletion of personnel), (medical checkups) as well as instructions for safe work, where necessary (e.g. use of means of individual protection, working at considerable height).

4.2 Health and Safety File

- 4.2.1 The Contractor shall appoint a safety engineer who shall also act as officer of safety and health issues, who assumes the responsibility to prepare the Site Safety Management Plan and the safety and health file at the design stage.
- 4.2.2 The health and safety file shall contain only the basic segments of the Project, as well as instructions and useful information in relation to health and safety issues which, possibly, may have to be taken into consideration during the subsequent phases of the design as well as during the Project’s life such as maintenance work, conversion work, cleaning, etc. For example, the instructions and details just referred to concern the safe performance of the various maintenance works, the prevention of hazards arising from the presence of the public utility networks (water supply, power supply, etc.), fire protection, etc.
- 4.2.3 It is pointed out that the Site Safety Management Plan and health and safety file constitute part of the Works and shall be submitted to the Engineer for review. It shall be updated as the works progresses and shall be available for viewing by the Engineer at any reasonable time.

4.3 General Health and Safety Requirements

4.3.1 Legislation and Regulations

- 4.3.1.1 The Contractor shall be subject to penal and civil laws for all injuries of his personnel, as well as personnel of the Employer and third parties, even when the Contractor has implemented the specifications given Notice of No Objection by the Employer. The Contractor shall perform all Works in a healthy and safe manner and in accordance with Philippine laws, Presidential Decrees, police and other regulations and directions of the Employer. If no relevant Philippine Laws, Presidential Decrees, police and other regulations exist, then the relevant standards and codes of practice and current best practice of acknowledged international codes shall apply. The Contractor shall also comply at all times with any other mandatory requirements, local safety, security, EIA report, Environmental Impact Statement (EIS) report and other regulations in force and to which the Works are subject, including any requirements specified by the Bureau of Fire Protection.
- 4.3.2.1 The Contractor shall ensure the safety of all operations in connection with the Project and shall take all necessary action to ensure the safety of all persons who may be on or adjacent to the Site, including the Employer’s staff and their agents, designated contractors and utility companies.
- 4.3.2.2 The Contractor shall provide and maintain, throughout the Project duration, all protection measures necessary for the protection and safety of all persons.
- 4.3.2.3 The Contractor shall comply immediately with all instructions from the Engineer in respect of the safety of the Works.
- 4.3.2.4 The Contractor shall ensure that all personnel on the Site are properly trained and supervised to ensure their safety and the safety of others while on Site.
- 4.3.2.5 The Engineer may require the immediate removal from Site of any person who, in the opinion of the Engineer, fails properly to observe the provisions of the relevant legislation, regulations and rules as appropriate, and any such other statutory regulations that from time to time may be in force. Such a person shall not under any circumstance return to the Site without the Engineer’s approval.
- 4.3.2.6 The contractor shall be responsible for all matters related to the safety and welfare of its Sub-Contractors and suppliers of any tier and all employees performing any part of

the Works on the Site, and shall comply in every respect with the provisions of all relevant statutory regulations, procedures, manuals and notices and with all requirements of Philippine laws as are applicable, including but not limited to:

- 4.3.2.7 ADB recommendation to DOTr concerning COVID-19 dated 21st May 2020:
- a) World Health Organization 2020. Considerations for Public Health and Social Measures in the Workplace in the Context of COVID-19. Geneva.
 - 1.2.1.1 <https://www.who.int/publications-detail/considerations-for-public-health-and-social-measures-in-the-workplace-in-the-context-of-covid-19>
 - b) Government of the United Kingdom. 2020. Working Safely During COVID-19 in Construction and Other Outdoor Work: Guidance for Employers, Employees and the Self-Employed
 - 2.2.1.1 <https://assets.publishing.service.gov.uk/media/5eb961bfe90e070834b6675f/working-safely-during-covid-19-construction-outdoors-110520.pdf>
 - c) The Canadian Construction Association. 2020. COVID-19 – Standardized Protocols for All Canadian Construction Sites.
 - 3.2.1.1 <https://www.cca-acc.com/wp-content/uploads/2020/04/CCA-COVID-19-Standardized-Protocols-for-All-Canadian-Construction-Sites-04-16-20.pdf>
- 4.3.2.8 The Contractor shall submit specific COVID-19 Risk Management Plan which shall be issued with the Bid and resubmit within 28 days of the Award of Contract. This resubmission shall contain modifications to reflect the changes which have occurred between the Date for Submission of the Bid and Award of Contract
- 4.3.2.9 The Contractor shall ensure that proper and adequate health and safety provisions, including those set out in this Project, are included in subcontracts placed by the Contractor. The consumption by Contractor's personnel of alcoholic drinks or partaking of any drug or other substance that might impair proper performance of their duties on the Site is strictly forbidden. The Contractor shall establish a policy, procedures and standards for providing a workplace that is free from harassment, intimidation, and threats. This includes but is not limited to threats of violence, physical challenges to fight, stalking, attempted assault, or assaulting by or against employees, customer employees, vendors, visitors, and members of the public.
- 4.3.2.10 The Contractor shall have a policy of “zero tolerance” regarding violence in the workplace and shall take all reasonable steps to prevent or address any acts or threats of this nature.

4.4 Site Safety Management Plan (SSMP)

- 4.4.1 The Contractor shall submit a Site Safety Management Plan in English. This plan shall include the approach and structure that the detailed plan shall take and, in particular, shall address the following items:
- a. The Contractor's Health and Safety Policy Statement;
 - b. The Contractor's organization and arrangements for health and safety. Particular reference shall be made to the site arrangements and procedures for ensuring compliance with health and safety legislation, regulations, codes of practice and, where relevant, National Standards and other international standards;
 - c. Nomination of a Safety Officer reporting to Project Manager who shall have an overview of all Site safety matters. The responsibilities, qualifications, training and experience of those nominated shall be specified. The name of the Safety Officer shall be made known to the Engineer. The name, address, educational qualification,

work experience and health condition of each personnel deployed for Safety, Health and Environment (SHE) jobs shall be submitted for the Engineer’s review well before the start of the work. Only after a success review by the Engineer are the safety personnel allowed to take up their roles. If any personnel leave the Project, then the same rigorous approach shall be used for their replacement;

- d. A schedule of safety procedures to be used on the Project, including those related to the maintenance and safe operation of Contractor's Equipment;
- e. The Contractor's procedures for reporting and investigating accidents, dangerous occurrences or occupational illness;
- f. The Contractor's policy and procedures for identifying and eliminating Site hazards. Reference shall also be made to mitigating measures which include procedures for the identification of the need for, and the provision of, Personal Protective Equipment (PPE), permits systems, safety rules and safety training;
- g. The Contractor’s Health and Safety Inspection and Audits procedure to verify whether the Health and Safety plan and objectives are being met. The inspection is purposely to identify any at-risk behaviors and conditions so that corrective measures can be implemented to eliminate or minimize associated potential hazards. This procedure also defines the type and frequency of Health Safety and Environment Safety inspections and Audits needed to meet Employer’s Requirements;
- h. The Contractor's emergency plan referred to in Sub-Clause 4.5.1.4. The Contractor shall prepare an emergency response plan for all Work Sites as a part of the Contractor safety and health plan. The plan shall integrate the Emergency Response Plans of the Contractor and all other subcontractors. The emergency response plan shall detail the Contractor’s procedures, including detailed communications arrangements, for dealing with all emergencies that could affect the Site. This shall include, where applicable, injury, sickness, evacuation, fire, chemical spillage, severe weather and rescue;
- i. Proposals for ensuring a mutual understanding between the Contractor and the Employer with regard to the elimination or mitigation of hazards on Site;
- j. Methods of integrating the Contractor and the Employer’s safe working practices and procedures and, where relevant, those of designated contractors, other contractors and utility companies;
- k. An outline program for safety tours and detailed safety inspections to identify any variation in construction activities and operations, machinery and equipment and processes against the Safety Plan and its supplementary procedures and programs;
- l. The Contractor's disciplinary procedures with respect to safety related matters;
- m. The Contractor's procedures for assessing the suitability of subcontractors with respect to health and safety;
- n. The Contractor's procedures for ensuring that their personnel are medically fit for the tasks they are carrying out. The procedures shall take into account working hours and environment; and
- o. The Contractor’s safety organizational chart.

4.4.2 Within forty-two (42) days from Commencement of the Works, the Contractor shall provide the Engineer with the finalized Site Safety Management Plan for his review, taking account of any directions or requirements from the Employer on the Site Safety Management Plan submitted. Where specific requirements cannot be complied with, the reasons shall be stated and any alternative arrangements specified. The finalized plan

shall also detail the measures that shall be implemented to eliminate or mitigate against the hazards identified out and specified by the Engineer during the review of the submitted plan.

- 4.4.3 The Contractor shall carry out monthly reviews of the measures contained within the Site Safety Plan to demonstrate that the required levels of safety are being achieved and maintained. The Contractor shall submit a full report to the Employer and the Engineer at monthly intervals for each such review.
- 4.4.4 The Engineer shall review the Site Safety Management Plan from time to time and shall advise the Contractor of any matter with which the Engineer is not satisfied, and the Contractor shall take such steps as are necessary to rectify this situation.
- 4.4.5 The Engineer shall carry out such safety studies or audits as considered necessary.
- 4.4.6 The Contractor shall make available specialist personnel as the Engineer may consider necessary for the performance of such safety studies or audits.

4.5 Site Safety Requirements

4.5.1 Site Organization and Arrangements for Safety

- a. Safety Supervisors
 - i. Prior to commencement of the actual Works, the Contractor shall appoint Site Safety Supervisors to provide adequate supervision, and shall supply to the Engineer the names and details of qualifications, experience and training of the persons so appointed. Before starting work, and at such other times as may be required by the Engineer, the Contractor's safety officer and safety supervisors shall meet the Engineer's safety representative to discuss and agree the safety measures to be implemented on Site. At all times when work is being carried out on the site, the Contractor's safety officer or a nominated deputy shall be available on the site to take immediate action on all safety matters.
- b. Site Safety Committee
 - i. The Contractor's safety officer or his designated representative shall attend meetings of a Site safety committee chaired by the Employer or Engineer, which shall meet at no less than monthly intervals. The Site safety Committee shall also include representatives of major subcontractors, designated contractors, utility companies, other authorities (fire brigade, police, etc.) and other specialists as the Employer may decide; and
 - ii. The Contractor shall act without delay upon decisions or recommendations made from time to time by the site safety committee with regard to general or particular matters of health and safety.
- c. Notification of Accidents
 - i. In the event of any recordable accident or dangerous occurrence arising at the Site during the execution of the Works, the Contractor shall comply with the legal requirements for reporting of injuries, diseases and dangerous occurrences; and
 - ii. In addition to any statutory reporting, the Contractor shall report to the Employer and the Engineer, within 48 hours, any accident or dangerous occurrence involving his personnel or other parties, that occurs on the Site.
- d. Emergency Procedures
 - i. The Contractor shall submit for review by the Engineer and include in the

- Site Safety Management Plan detailed proposals for any reasonably foreseeable emergency, stating the procedures to be adopted for each emergency. The Contractor's emergency plan shall detail the duties and responsibilities of personnel on Site and in particular shall identify a senior site official with responsibility for liaising with the emergency services. The emergency plan shall also include the names and telephone numbers of the Contractor's staff who would be available to organize or assist with emergency action in the event of an incident occurring on the Site outside the Contractor's normal working hours.
- ii. Copies given Notice of No Objection of an emergency plan and procedures shall be produced by the Contractor and distributed and displayed at each place of work together with any other documents, posters or notices which the Employer may direct or are required by law.
 - iii. Arrangements shall be made for emergency medical treatment and evacuation of the victim in the event of an accident or dangerous incident occurring, the chain of command and the responsible persons of the Contractor with their telephone numbers and addresses for quick communication shall be adequately publicized and conspicuously displayed in the workplace.
 - iv. The Contractor shall require to liaise with the hospitals and fire stations located in the neighborhood for attending to the casualties promptly. The Contractor shall conduct an onsite emergency drill in every month for all of his workers and his subcontractor’s workers before starting work on the Site. The Contractor shall ensure that all of his personnel are:
 - Informed of the procedure for calling the Fire Brigade and other emergency services; and
 - Informed of and understand fully the evacuation procedures from the Work site(s).

4.5.2 Personal Protection

- a. Personal Protective Equipment (PPE)
 - i. The Contractor shall undertake a survey and needs analysis of PPE requirements for the Works and shall provide all appropriate PPE for his personnel. In addition, the Contractor shall provide 15 sets of PPE to the Engineer and Employer;
 - ii. The PPEs and safety appliances provided by the Contractor shall be of the required standard. If materials conforming to standards are not available, the Contractor as given Notice of No Objection by the Employer shall procure PPE and safety appliances as soon as possible, in liaison with the Employer;
 - iii. The Contractor shall provide and enforce the wearing of approved safety helmets and footwear and where necessary, eye goggles, ear protectors, safety harnesses, safety vests and other Personal Protective Equipment. The Contractor shall ensure that all persons on Site wear PPE at all times in areas where PPE is required; and
 - iv. Wherever work is carried out on or near to the MCRP and NSRP-South facilities, particularly at a carriage way, or adjacent to a public way, the Contractor shall ensure that personnel shall, at all times, wear high visibility fluorescent garments.

- b. Permit to Work
 - i. Wherever there are potentially hazardous conditions, the Contractor shall consider whether operating a "Permit to Work" system would reduce the hazards; and
 - ii. The Contractor shall secure necessary work permits where statutory requirements exist.
 - The Contractor shall develop a work permit system, which is a formal written system used to control certain types of work that are potentially hazardous. A work permit is a document, which specifies the work to be done, and the precautions to be taken. Work permits form an essential part of safe systems of work for many construction activities. They allow work to start only after safe procedures have been defined and they provide a clear record that all foreseeable hazards have been considered. Permits to work are usually required in high-risk areas as identified by risk assessments.

4.5.3 Safety of Equipment of the Contractor

- a. Contractor's Equipment, Tools, and Vehicles
 - i. The Contractor shall ensure that their own and their subcontractor's tools, equipment and vehicles required for the execution of the Works are maintained in a safe condition and are used only by trained operators; Equipment shall be examined and checked by the Contractor prior to delivery to Site or placed into service to ensure that it is operating in a safe mode;
 - ii. The Contractor shall ensure that all equipment is maintained in a thoroughly serviceable condition and, where appropriate, the equipment shall be included in a preventive maintenance program or subjected to pre-use inspections. Maintenance records and programs shall be made available to the Engineer when required. Any item of tools or equipment considered by the Engineer to be unserviceable or unsafe, shall not be used and shall be removed from the Site without delay;
 - iii. Where appropriate, the Contractor shall provide the Engineer with the most recent statutory inspection certificates in respect of all tools and equipment subject to statutory inspections, together with recent maintenance records for all items of equipment and tools which are being used onsite; and
 - iv. The Contractor shall ensure that any noise-emitting equipment which is required to be operated continuously or at night, shall be housed in a suitable acoustic enclosure. The requirements of Sub-Clause 9.8 shall apply with respect to noise disturbance.

- b. Contractor's Lifts and Hoists and Other Lifting Equipment
 - i. All hoisting facilities shall satisfy the relevant legislative requirements;
 - ii. The Contractor shall operate all cranes strictly in accordance with national standards for the safe use of cranes. All cranes, hoists and the like shall be fitted with overload warning devices;
 - iii. To enable the Engineer to approve the use of the crane, the Contractor shall

provide, as a minimum, the following information at least 12 days before bringing a crane to the Site:

- Information concerning lifting capacity at various radii;
 - Wheel, track and outrigger loads under travelling and lifting conditions;
 - Details of crane positioning and load delivery route required for any lifting operation;
 - The dimensions and weights of the items to be lifted;
 - The positioning of crane outriggers and the tail swing of any counterweights;
 - The proximity of the crane and the working envelope, relative to the nearest operational running line or siding, if any; and
 - The orientation of the crane jib relative to any structure, running line or siding and a risk assessment of the crane jib collapsing or the crane overturning;
- iv. Competent operators and banks men shall be clearly identified and shall be in possession of current certificates of training and personal protective equipment (PPE);
- v. The safe working load shall be clearly and indelibly marked on all lifting equipment; and
- vi. The Contractor shall prepare and maintain an up-to-date register containing test certificates of all lifting and hoisting equipment used on the Site. The register shall be available on Site from the commencement of construction for inspection by the Engineer and other relevant authorities.

c. Contractor's Access Equipment

- i. Work shall not be carried out from a ladder, if the type of work cannot be carried out safely. Ladders shall only be used for the purpose for which they are designed;
- ii. The Contractor shall ensure that all scaffolds erected on the Site shall be erected in accordance with the relevant national regulations. The Contractor shall arrange for full information and details concerning the permitted use and loadings of scaffolds to be clearly displayed on the scaffolds. The Contractor shall not permit any person other than a qualified operative to alter, erect, dismantle or otherwise interfere with any scaffold on the Site. Any scaffold being altered or dismantled or otherwise not suitable for use shall have a notice erected warning that it must not be used;
- iii. The Contractor shall ensure that only experienced persons are permitted to carry out work on staging erected in roof areas and that all necessary safety harnesses and anchorage points are provided and used; and
- iv. No scaffold, ladder, trestle, or staging shall be used unless:
- It has been inspected during the preceding seven (7) days and properly tagged as inspected and is safe for use;
 - It has been inspected after rough set-up, which may have affected stability and safety; and

- The details of each inspection have been recorded. Records are not required for scaffolds under 2 meters in height or for ladder or trestle scaffolds. All inspections shall be made by a competent person.
- d. Temporary Lighting and Power Supplies
- i. If so required under the Project, the Contractor shall provide and maintain adequate lighting and power supplies for all parts of the Site;
 - ii. All electrical installations shall comply with the current regulations for electrical installations;
 - iii. The Contractor shall give to the Engineer a copy of all certificates prepared upon completion of electrical installations and prepared for the periodic checks as required in accordance with the current regulations. Periodic check certificates shall also be supplied whenever substantial alteration is made to an installation. The Contractor shall appoint a certified person to be solely responsible for ensuring the safety of all temporary electric equipment on the Site; and
 - iv. All temporary electrical, installations which are associated with work on the Employer’s property shall be in conformance with the relevant local standards and be made available for an Engineer’s inspection when requested.

4.5.4 Site Hazards

- a. Cleanliness of the Site
- i. The Site shall be maintained in a clean, tidy and safe condition. The Contractor shall ensure that flammable materials, e.g. paper, cardboard, oily rags, etc. do not accumulate. Spillage of hazardous liquids shall be mopped up immediately or absorbed in sand or other suitable material, which shall be disposed of by the Contractor in a manner appropriate to the spillage;
 - ii. The Contractor shall immediately remove and dispose any kind of refuse, inappropriate, loose, redundant materials or sludge that have been dumped either voluntarily or involuntarily. Household waste shall immediately be disposed of to a covered litter box or plastic bags to be collected by the Local Authority. Burning of waste or other materials is strictly prohibited;
 - iii. All access shall be kept clean of obstructions at all times;
 - iv. Air hoses for pneumatic tools and gas hoses for welding equipment shall be kept clear of footways. Electric cables shall be routed to avoid tripping hazards and the possibility of damage by vehicles. Where cables or hoses need to cross routes, they shall be suitably boarded over; and
 - v. Pipe lengths or timber shall not be left lying about, especially pieces of wood with projecting nails or metal with sharp or jagged edges.
- b. Control Against Insects and Rodents
- i. The Contractor shall ensure that the conditions shall not be favorable for the development of insects and rodents in the worksite area. The aforementioned is valid for any areas or installations occupied by the Contractor outside the worksite boundaries, throughout their occupation; and

- ii. Whenever, the presence of insects or rodents is observed, the Contractor shall carry out disinfection/rodent eradication according to the Engineer’s review.
- c. Protection Against Fire
- i. The Contractor shall take strict precautions to protect the Site, the Employer’s property and all personnel on the site from damage or injury due to fire;
 - ii. The Contractor shall not burn any waste or other material on Site;
 - iii. The Contractor shall follow safe procedures for removing tanks and pipes, which may have contained flammable liquids. In particular, the Contractor shall take adequate precautions to prevent fire or explosion caused by gas or vapor;
 - iv. The Contractor shall keep all exits, signs and means of access clear of obstructions, particularly access to fire-fighting equipment and emergency stairs and doors;
 - v. The Contractor shall heat water using electric immersion heaters only and space heating shall be by electric convectors. All appliances shall be securely fixed;
 - vi. The Contractor shall comply with international and national fire safety standards with respect to all materials, which are to be incorporated in the Permanent Works; and
 - vii. The Contractor shall comply with international and national fire safety standards with respect to all temporary works in areas of interface with the existing PNR system.

4.5.5 Health Hazards

- a. Hazardous Materials
- i. The Contractor shall impose necessary controls and procedures for the safe handling of hazardous substances; and
 - ii. Specific requirements related to the control of exposure to asbestos and lead are outlined in Sub-Clauses 4.5.5-2 and 4.5.5-3, respectively.
- b. Asbestos
- i. The Contractor shall not deliver any asbestos materials to the Site;
 - ii. The Contractor shall submit to the Engineer for his review details of any friction materials containing asbestos, which are proposed to form part of the Works. Such materials or the equipment containing such materials shall be clearly labelled in accordance with the relevant regulations;
 - iii. The Contractor shall comply with international and national regulations for the control of asbestos. The Contractor shall immediately cease work, cordon off the area and inform the Employer and the Engineer if any asbestos is discovered during the course of the Works. Qualified personnel shall carry out asbestos surveys;
 - iv. Where any work shall result in exposure to asbestos, the Contractor shall submit for review by the Employer and the Engineer his proposals for

carrying out the remedial measures that may be required to comply with third paragraph of Sub-Clause 4.5.5-2; and

- v. The Contractor shall not commence any work on the MCRP and NSRP-South Line which necessitates contact with asbestos, until the area or installation has been visited by the Employer’s specialist for asbestos control and removal measures as instructed by the Engineer have been completed.
- c. Lead
 - i. The Contractor shall ensure that any work involving the use of lead in any form shall be planned and carried out in accordance with International and National regulations for the control of lead at work. The regulations apply to any work including any type of handling, moving, storing, processing or otherwise, that exposes any person to lead, including any work from which lead arises. This shall include:
 - In the form of lead dust, fume or vapor in such a way that it could be inhaled;
 - In any form which is liable to be ingested such as powder, dust, paint, or paste; and
 - In the form of lead compounds such as concentrated lead alkyl which could be absorbed through the skin.
 - d. Ionizing Radiation
 - i. The Contractor shall implement measures to control exposure and dosage due to all sources of ionizing radiation, if any, which shall be subject to statutory controls.
 - e. Noise
 - i. The Contractor shall impose controls and conduct any assessments as required regarding statutory noise regulations, EIS report and EIA report(s). Copies of noise assessments shall be made available for inspection by the Employer and the Engineer. Further requirements with respect to disturbance from noise are set out in Sub-Clause 9.8.
 - f. Contaminated Water
 - i. The Contractor shall ensure that all personnel working in contact with drainage water are suitably safeguarded. In particular, the Contractor shall ensure that his personnel:
 - Are aware of the provisions related to men working in contact with sewage, etc. The Contractor at a point shall display this notice or a card or a suitable alternative as agreed by the Engineer, which is conspicuous to all personnel working in such conditions;
 - Are provided with and wear all necessary protective clothing and equipment. In addition to overalls and gloves this shall include a facemask (respirator) and goggles where splashing may occur
 - Are advised of the nearest washing area and are provided with waterless

- hand cleanser and towels where clean running water is not available in the working area;
 - Only consume food in a designated rest room or clean area;
 - Cover all cuts, scratches or abrasions with waterproof plasters; and
 - Enforce a no smoking policy.
- ii. The Contractor shall take special precautions to protect all of his personnel and others attending the site from Leptospirosis (Weils’ Disease). Recommended precautions are the wearing of protective clothing and the elimination of rat infestation.

4.5.6 Fire Protection

- a. Minimizing Fire Hazards
- i. Fire hazards include but are not limited to the following:
- Electric traction supplies and contact wire systems;
 - Pantograph and arrestor;
 - Traction controller and traction motor;
 - Auxiliary power supply system and batteries;
 - Air-conditioning system;
 - Electrical wiring;
 - Brake pads;
 - Oil/fuel spillages;
 - General combustible materials (wood, paper, etc.); and
 - Welding tools, grinding tools, cutting tools, etc.
- b. The Contractor shall minimize the potential fire risks in the work. Consideration shall be given to the Site supervisory controls necessary to ensure a low risk of fire. The Contractor shall also:
- i. Establish adequate means of fire-fighting and provide suitable extinguishers, hoses and other appliances at selected locations;
 - ii. Establish arrangements for calling the local fire brigade by telephone and other means such as radio;
 - iii. Pay particular attention to the design of all electrical and mechanical systems, avoid overloading the electrical supply system and maintain equipment in good working order;
 - iv. Ensure that all personnel are fully trained in the use of fire-fighting equipment and rescue procedures;
 - v. Adopt a 'Permit-to-Work' system for special operations, particularly those that carry a relatively high fire risk;
 - vi. Promote general tidiness and cleanliness and ensure the removal of all flammable materials from working places when not required;
 - vii. Identify all possible sources and categories of fire and the appropriate means

- of fire fighting; and
- viii. Strictly enforce a ban on smoking except in designated smoking areas.

c. Control of Dangerous Work

- i. The Contractor shall not carry out any flame cutting, welding, grinding, spark producing or similar hot work operation involving risk of fire without approval from the Engineer and the following shall apply:
 - If hot working is likely to be undertaken, the Contractor shall advise the Engineer of the need for such hot work and agree with the Engineer all precautions to be implemented throughout the duration of the hot work;
 - The use of thermic lance or any paraffin/gas blowpipe shall not be permitted;
 - The Contractor shall limit as far as is reasonably practicable the emission of smoke or any noxious or pungent fumes and he shall protect all persons within the vicinity;
 - The Contractor shall provide a competent and trained fire watchman for the whole duration of any hot working. The fire watchman shall be trained in the use of various types of extinguishers and other fire-fighting equipment and he shall ensure that an adequate supply of appropriate fire-fighting materials and equipment is readily available whilst burning or welding works are underway. The fire watchman shall not be engaged on other duties and shall remain on fire duty for at least one hour after the completion of welding or burning work to ensure there is no possibility of the outbreak of fire; and
 - Only qualified welders or fitters tested in accordance with this Specification shall be permitted to burn or weld. They shall not be permitted to work alone but shall be accompanied by a competent fire watchman.

4.6 Safety Requirements on or Adjacent to the MCRP and NSRP-South Line

4.6.1 Notification of Accidents

4.6.1.1 In the event of any incident or dangerous occurrence on or about the MCRP and NSRP-South Line during the carrying out of the Works, the Contractor shall comply with statutory requirements for notification of accidents. A copy of the notification shall be given to the Employer, in order that the Employer may comply with statutory requirements as appropriate.

4.6.1.2 The Contractor shall maintain records of the activities of its personnel carrying out the Works. In the event of an incident affecting the operation of the MCRP and NSRP-South Line, the Contractor may be required to give evidence to an investigation team if the Contractor's work is involved.

4.6.2 Safety on the MCRP and NSRP-South Line

a. Person in Charge on Site

- i. The Contractor shall appoint a responsible person as the Person in Charge on Site for any work carried out on the MCRP and NSRP-South Line. The Contractor shall ensure that the Person in Charge on Site has been trained

and is clearly identifiable. The Contractor shall provide, for review by the Engineer, the names and details of qualifications, experience and training of the persons so appointed. The appointed Person in Charge on site may also act as Safety Supervisor per Sub-Clause 4.5.1- 1, for any particular shift.

- b. Work in Traffic Hours on the MCRP and NSRP-South Line
 - i. Where the Contractor is required to work in traffic hours on the MCRP and NSRP-South Line but not closer than 2 meters from the nearest track, the following safety precautions shall be observed:
 - The Contractor shall make all arrangements necessary for the safe and efficient protection of the trains and the public and shall provide and maintain all temporary structures, shields, fences, close boarded decks and protective screens to such sizes and of such types as may be given Notice of No Objection by the Employer. The Contractor shall erect such protective arrangements during track occupations;
 - The Contractor shall ensure that his personnel and equipment do not encroach on or cross the track; and
 - When work is being carried out at places where the Track is electrified, the Contractor shall issue to all personnel engaged on the work any instructions supplied by the Engineer/Employer regarding the danger to persons working in proximity to the overhead supply lines, cables, wires and electrical equipment and shall see that such personnel are made fully conversant with such instructions and that they are strictly obeyed. The Contractor shall display warning posters of the potential hazards in prominent positions on the Site.
- c. Work on the Track
 - i. All work, and the movement of men and materials to be executed in any of the circumstances detailed below shall only be carried out during engineering hours:
 - Any work within 2 meters horizontally and 4.2 meters vertically from the nearest running rail, with the exception of work on platforms;
 - Any work involving the lifting or placing of objects in such a position and in such a manner that either the objects or the lifting equipment might be a danger to the MCRP and NSRP-South at any stage during the operation;
 - Any work requiring access to be gained along or adjacent to the track or restricted clearance areas; and
 - Any other work which, in the opinion of the Employer, could endanger the MCRP and NSRP-South.
- d. Track Occupation during Engineering Hours
 - i. Occupation of the track during engineering hours shall be arranged by the Employer and shall normally be granted after the traction current has been switched off. All staff, equipment and materials shall be cleared off the track within not less than 20 minutes, or such other period as the

- Engineer/Employer may decide, before the traction current is switched on again;
- ii. The Contractor shall not commence work without the Engineer’s/Employer’s Safety Officer/s being in attendance to enforce the Employer’s “Site Safe Procedure”;
 - iii. The duration of the period of occupation may be interrupted by the passage of an engineering vehicle and all work shall be suspended as and when directed by the Engineer/Employer during the passage of the vehicle. Under no circumstances shall cranes or machines be allowed to work after the approach of a vehicle has been signalled or warning given of the approach of a vehicle, until such vehicle has been passed clear of the Site;
 - iv. When work has ceased at the end of each shift all exposed uncompleted work shall be protected with hoarding; and
 - v. Panels of hoardings on platforms or adjacent to the track which are removed during engineering hours shall be securely replaced to the Engineer’s/Employer’s satisfaction not less than thirty minutes, or such other period as the Engineer/Employer may decide, before the start of traffic hours.
- e. Engineer’s/Employer’s Safety Officer/s
- i. The Contractor shall, before commencing any work on or adjacent to the Track, give adequate notice to the Engineer/Employer of his intention to work and arrange with the Employer for the attendance for the duration of the work of the Engineer’s/Employer’s Safety Officer(s).

4.6.3 Safety Training Requirements

- a. Training Requirements
- i. No member of the Contractor's personnel shall work on the MCRP and NSRP-South system and in particular on or adjacent to the track without first having attended and passed the relevant safety training courses including those outlined below.
 - ii. All personnel attending the safety training courses shall first undergo a medical appraisal, which shall satisfy the standards for such appraisals. All persons shall be declared medically fit as a pre-requirement to attending the training courses and working on the MCRP and NSRP-South Line.
 - iii. The Contractor shall organize quality SHE training to engage managers, supervisors and other personnel/workers in behavioral change and improve safety performance. The Contractor shall analyze the training requirements for all the employees and initiate a training program to demonstrate that all persons employed, including subcontractors are suitably qualified, competent and fit.
 - iv. A matrix and schedule of training requirements covering general, task-specific and SHE-related training and showing the training frequency and interval between refresher courses shall be maintained.
 - v. The training courses shall be provided by the Contractor. All other expenditure incurred by the Contractor as a result of his personnel attending the courses or medical appraisal shall be borne by the Contractor.

- b. Fire-Fighting and Evacuation
 - i. The Contractor shall ensure that all personnel on Site are properly trained in the fire precautions to be observed in the course of the work, the use of fire-fighting equipment maintained on Site, the actions to be taken in case of fire, and the fire evacuation procedures from sub-surface sections of the MCRP and NSRP-South Line and within station premises.

- c. Training of Contractor's Personnel for the System and the Track
 - i. All Contractor's personnel who shall be or may be carrying out work or who may require access on or adjacent to the MCRP and NSRP-South Line or the track, shall attend a course arranged by the Engineer/Employer before commencing any such work or obtaining any access. Contractor's personnel attending the course shall wear suitable clothing including boots or shoes for walking along the track and shall have in their possession a high visibility vest.

4.6.4 Use of Radios

- 4.6.4.1 The Contractor shall ensure that the use of personal radio sets or other similar electrical equipment (including personal stereo sets with headphones but excluding hearing aids) is forbidden in all areas of the MCRP and NSRP-South Line.
- 4.6.4.2 The Contractor shall seek approval for the use of radio transceivers on the Employer’s premises. A written request shall be submitted to the Engineer/Employer at least 14 days before the proposed use of the radio equipment and the request shall include information on output power and allocated frequency.

4.6.5 (Not Used)

4.6.6 Hot Working

- 4.6.6.1 The Contractor shall ensure that Hot Working is carried out in accordance with the following requirements in addition to those specified in Sub-Clause 4.5.6-2).
- 4.6.6.2 Permits for hot working shall be applied for by the Contractor from the Engineer not less than 48 hours prior to the proposed commencement date of the operation.
- 4.6.6.3 The Contractor shall not undertake any hot work anywhere within the confines of the operating MCRP and NSRP-South Line during traffic hours without the approval of the Engineer.
- 4.6.6.4 Where hot working is to be carried out in any part of the Works which is connected to the MCRP and NSRP-South Line, the Engineer/Employer may also supply a fire watchman in addition to the Contractor's responsibilities as set out in Sub-Clause 4.5.6-2). If the attendance of the Engineer’s/Employer's fire watchman is considered necessary, work shall not commence until he is in attendance.

4.6.7 Safety of Equipment and Plant of MCRP and NSRP-South

- a. MCRP and NSRP-South Line Equipment
 - i. All work shall be carried out in such a manner so as to ensure the safety of the NCSR Line, to prevent damage to MCRP and NSRP-South’s equipment and to require the absolute minimum of alteration to such equipment.

- b. Screening of Lights
 - i. All lights or lasers provided by the Contractor shall be so placed as not to cause any confusion with or so as not to interfere with any signal lights on the MCRP and NSRP-South Line. If directed by the Engineer, the Contractor shall forthwith remove such lights and lasers and replace them in a position given Notice of No Objection by the Engineer. Such approval shall not preclude the Engineer from giving further directions as to such replaced lights or lasers.

4.6.8 Fire Protection Requirements

- a. The Contractor shall ensure that, on the Employer's operating premises, they maintain the integrity of compartmentation of rooms and areas throughout the duration of the Works. The Contractor shall agree with the Engineer/Employer the means of ensuring such integrity of compartmentation and maintenance of the fire protection systems installed on the Employer's premises. The Contractor shall not obstruct access to fire-fighting equipment, nor isolate fixed fire protection or detection equipment unless given Notice of No Objection by the Engineer.
- b. Fire Performance of Temporary Hoardings in Enclosed Areas
 - i. The fire performance criteria and approved painting systems for temporary hoardings in enclosed areas shall be given Notice of No Objection by the Engineer.
- c. Storage and Use of Gas Cylinders, Flammable and Volatile Materials
 - i. The Contractor shall not take or store anywhere on the MCRP and NSRP-South Line any cylinders of industrial or flammable gases, including Oxygen, and containers or flammable and volatile materials without the prior written permission of the Engineer/Employer;
 - ii. The Contractor shall make arrangements for any storage of flammable and volatile material, including Oxygen, to be strictly controlled during the period of the Works;
 - iii. Gas cylinders and flammable and volatile materials shall be stored only at ground level and in locations given Notice of No Objection by the Engineer. The storage areas shall be in a position that shall not cause an obstruction to passageways, and staff accommodation and not be near any source of ignition. Gas cylinders shall be stored in locked cages and be vertical and properly supported. Hoses and cylinder keys shall be removed from cylinders and kept away from the cylinders. Flammable and volatile materials shall be stored in locations separate from gas cylinders and in sealed metal containers with a maximum storage of all materials in one place of 0.025 m³.
- d. No Smoking Policy
 - i. The Contractor shall throughout the progress of the Works, strictly enforce the Employer's ban on smoking in the Project Site, except in the designated smoking areas on the MCRP and NSRP-South System.

4.6.9 Hazardous Materials

4.6.9.1 In addition to the requirements of Sub-Clauses 4.5.5, the Contractor shall comply with the Employer's engineering instructions with respect to the use, storage, licensing and inspection of storage facilities for hazardous materials. All hazardous materials shall be accompanied with a Material Safety Data Sheet (MSDS).

4.6.10 Delivery and Handling of Materials and Equipment

4.6.10.1 The delivery of materials, equipment by the Contractor through public areas of the MCRP and NSRP-South Line shall be undertaken only during engineering hours.

4.6.10.2 The Contractor shall not place any material or equipment within 2 meters from the nearest running rail unless given Notice of No Objection by the Engineer/Employer.

4.6.10.3 The Contractor shall submit to the Engineer, for review, proposals for any lifting of heavy items, storing or transporting of materials and equipment on or along MCRP and NSRP-South premises. The Contractor's proposals shall include information on floor loads. The Contractor shall provide at least two (2) weeks' notice of his intention to carry out such work.

4.6.11 Barriers/Board-ups Protection

4.6.11.1 The purpose of the procedure is to ensure the health and safety of all personnel involved with, and working around the working perimeter including the general public throughout the Project period.

4.6.11.2 Safety measures relating to adequate protection of pedestrian crossings or walkways, covering, protection and securing of cables and hoses, warning signs for display at conspicuous places wherever necessary, adequate lighting at board-ups and barriers and availability of security personnel during work operation and to provide pedestrian and traffic control at the work Site shall be included in the Procedure.

4.6.11.3 Board-ups must be substantially and properly constructed all around the Site perimeter. Periodical checking of Site board-ups is essential and they shall be constructed according to the design requirements.

4.6.11.4 Barriers must be provided and complying with Philippine Department Order 13 and 16 and OSHS, if necessary.

4.6.12 Confined Space Entry

4.6.12.1 Personnel are at times required to enter confined spaces to clean, inspect, repair, and perform other duties associated with the equipment or the process. Confined spaces that are potentially hazardous include but are not limited to a space that:

- a. Is large enough and so configured that an employee can bodily enter and perform assigned work;
- b. Has limited or restricted means for entry or exit (for example: tanks, vessels, silos, storage bins, hoppers, vaults, and pits, or spaces that may have limited means of entry);
- c. Is not designed for continuous employee occupancy; and
- d. Has inadequate flow of natural ventilation.

4.6.12.2 Potential hazards (specifically toxic vapors), in unhealthy or fatal concentrations may result from residue of the last material in the confined space hence, the need for addressing this safety concern.

- 4.6.12.3 In any confined-space activity a confined-space entry permit is necessary.
- 4.6.12.4 The Contractor shall recognize applicable policies and procedures necessity for different standards/policies for different confined space entry applications. However, Occupational Safety and Health Standards, and Philippines’ Department Order 13 and 16, Philippines, shall still be adhered to.

4.6.13 Lock Out and Tag Out

- 4.6.13.1 The Contractor shall establish minimum procedures to ensure the safety and health of personnel who may work on any type of equipment capable of being energized or storing energy.
- 4.6.13.2 Specific energy control procedures must be developed in writing for each operation covered under the purpose and scope of the Lock Out and Tag Out procedure.
- 4.6.13.3 General requirements in performing any undertaking for this safety procedure shall be delineated in detail and pertinent methodology shall be defined, including directives set forth in the work instructions.
- 4.6.13.4 Procedures and programs to be formulated for the Safety Procedure shall be in conformity with the Department of Labor and Employment (DOLE), Occupational Health & Safety Standards, the Philippine Electrical Code and Department Order 13 and 16 of the Philippines.

4.6.14 Energized Electrical Works

- 4.6.14.1 The Contractor shall adopt a procedure that applies in all situations where exposure to energized or potentially energized electrical equipment is possible due to the nature of the work to be performed. Adhering to these procedures shall help to ensure that electrical work is conducted under the safest possible conditions.
- 4.6.14.2 The procedure shall comprehensively define the work practices for these safety matters.
- 4.6.14.3 All works must be performed in accordance with the provisions set forth in the written procedures and in compliance with all other applicable safety requirements.
- 4.6.14.4 Contractor’s employees who perform, or who have potential to perform work on energized, or potentially energized electrical equipment, wiring, distribution systems, circuits, etc. shall be qualified electricians, designated and authorized by the Site Manager once the qualification and training requirements of local legal authorities are met.
- 4.6.14.5 The procedure shall meet the Philippines’ Department of Labor and Employment (DOLE), Occupational Health & Safety Standards and the Philippine Electrical Code requirements.

4.7 Occupational Health and Welfare

4.7.1 Physical Fitness for Workers

- 4.7.1.1 The Contractor shall ensure that his employees/workers subject themselves to such medical examinations as required under the law or under the contract provisions and keep a record of the same.
- 4.7.1.2 The Contractor shall not permit any employee/workmen to enter the work area under the influence of alcohol or any drugs.

4.7.2 Medical Facilities

4.7.2.1 Medical Examination

- a. The Contractor shall arrange a medical examination of all his employees including his sub-contractors’ employees employed as drivers, operators of lifting appliances and transport equipment before employing them, after illness or injury, or if it appears that the illness or injury might have affected their fitness. The Contractor shall maintain the confidential records of medical examination or the physician authorized by the Employer.
- b. No building or other construction shall be charged for the medical examination and the cost of such examination shall be borne by the Contractor employing the said worker.
- c. The medical examination shall include:
 - i. Full medical and occupational history.
 - ii. Clinical examination with particular reference to:
 - General Physique;
 - Vision: Total visual performance using standard orthorator like the Titmus Vision Tester shall be estimated and suitability for placement ascertained in accordance with the prescribed job standards;
 - Hearing: persons with normal hearing must be able to hear a forced whisper at twenty-four feet. Persons using hearing aids must be able to hear a warning shout under noisy working conditions;
 - Breathing: Peak flow rate using standard peak flow meter and the average peak flow rate determined out of these readings of the test performed. The results recorded at pre-placement medical examination could be used as a standard for the same individual at the same altitude for reference during subsequent examination;
 - iii. Spine: adequately flexible for the job concerned;
 - iv. Lower Limbs: Adequate leg and foot mobility; and
 - v. General: mental alertness and stability with good eye, hand and foot coordination.
- d. Any other tests which the examining doctor considers appropriate.

4.7.2.2 First-aid Boxes

- 4.7.2.2.1 The Contractor shall ensure at all construction sites a first-aid box is provided and maintained for providing first-aid to the workers.

4.7.2.3 HIV/AIDS Prevention and Control

- a. The Contractor shall adopt the Employer’s Policy on “HIV/AIDS Prevention and Control for Workers Engaged by Contractors”.
- b. The Employer shall engage a professional agency for implementing the guidelines laid down in the policy and communicate these guidelines to the Contractor.
- c. The Contractor shall extend necessary support to the appointed agency by deputizing the workers to attend the awareness creation programs.
- d. The Contractor shall also extend necessary organizational support to the appointed

agency for the effective implementation of the Employers’ workplace policy on HIV/AIDS for workers of the Contractors.

4.7.2.4 Prevention of Mosquito Breeding

- a. Measures shall be taken to prevent mosquito breeding at Site. The measures to be taken shall include:
 - i. Empty cans, oil drums, packing and other receptacles which may retain water shall be deposited at a central collection point and shall be removed from the Site regularly;
 - ii. There shall not be accumulation of still water at any Site, in case of still water, it shall be covered by earth and leveled;
 - iii. Contractor’s equipment and other items on the Site which may retain water shall be stored, covered or treated in such a manner that water could not be retained; and
 - iv. Water storage tanks shall be provided.

4.8 Noise

- a. The Contractor shall consider noise as an environmental constraint in their design, planning and execution of the Works and provide demonstrable evidence of the same at the Employer’s request and shall refer and comply to the EIA report and EIS report.
- b. The Contractor shall, at his own expense, take all appropriate measures to ensure that work carried out by the Contractor and by his sub-contractors, whether on or off the Site, shall not cause any unnecessary or excessive noise which may disturb the occupants of any nearby dwellings, schools, hospitals, or premises with similar sensitivity to noise.
- c. Without prejudice to the generality of the foregoing, noise level reduction measures shall include the following:
 - i. The Contractor shall ensure that all powered mechanical equipment used in the Works shall be effectively sound-reduced using the most modern techniques available including but not limited to silencers and mufflers; and
 - ii. The Contractor shall construct acoustic screens or enclosures around any parts of the Works from which excessive noise may be generated.
- d. The Contractor shall ensure that noise generated by work carried out by the Contractor and his sub-contractors during daytime and night time shall not exceed the maximum permissible noise limits.

4.9 Welfare Measure for Workers

4.9.1 Latrine and Urinal Accommodation

- 4.9.1.1 The Contractor shall provide sufficient latrine seat and urinal accommodation at Site. When women are employed, separate latrine accommodation shall be provided.

4.9.2 Drinking Water

- 4.9.2.1 The Contractor shall make in every worksite, effective arrangements to provide sufficient supply of portable water with minimum quantity of 5 liters per worker per

day.

4.9.2.2 Quality of the drinking water shall conform to the requirements of national standards on public health.

4.9.2.3 While locating these drinking water facilities due care shall be taken so that these are easily accessible from the place of work for all workers at all location of work Sites.

4.10 Gender and Development (GAD)

4.10.1.1 The Contractor shall adopt the Gender and Development (GAD) policy that comply with but not limited to local authorities’ guideline for GAD. The contractor shall submit within 60 days from the Commencement Date of Works the following for the Employer’s assessment and approval:

4.10.1.1.1 Code of Conduct

- a. The Contractor shall furnish a copy of their Code of Conduct which should include specific prohibition of any sexual activity of any sexual activities with children, defined as anyone under the age of 18, residing in the project area. It shall also further define a range of sanctions proportionate to the event, for example, warnings for incidents of community harassment, such as cat calling, versus dismissal for incidents of sexual abuse.

4.10.1.1.1 Gender-Based Violence (GBV) Action Plan

- a. A GBV Action Plan, which should include mechanisms, sanctions, and mitigation procedures in handling GBV-related cases during project implementation. The GBV Action Plan must be compliant with the Legal and Policy Framework provided by the Employer. It shall properly address the requirements stated under GC 6.8, 6.9, and 6.11.
- b. The Contractor has the following options in formulating the GBV Action Plan:
 - i. Sub-Contracting a local GBV Service Provider
 - The Contractor has the option to subcontract a local GBV Service Provider to handle GBV-related cases during project implementation.
 - The Contractor shall submit a company profile of their nominated GBV Service Provider as part of the Bidding Documents, for the Employer’s assessment and approval. The nominated GBV Subcontractor must provide items listed in Section (ii), to measure their capacity in handling GBV-related cases for the project.

4.2.1.1

ii. Formulation of a project-specific GBV Action Plan

- Contractors should demonstrate that they have the capacity to manage GBV risks. For the project’s GBV risks to be properly addressed, it is necessary to have an effective ‘GBV Action Plan’, which outlines:

5.2.1.1

- (1) How the project will put in place the necessary protocols and mechanisms to address the GBV risks; and,
- (2) How to address any GBV incidents that may arise.

The GBV Action Plan needs to include specific arrangements for the

project by which GBV risks will be addressed. This includes components such as:

- (3) Awareness Raising Strategy, which describes how workers and local communities will be aware and sensitized to GBV risks, and the Employer’s responsibilities under the CoC;
- (4) Policies Governing the Workplace, which details clear policy regarding non-tolerance of sexual harassment in the workplace. These are also expected to be included, as minimum requirements, in the Contractor’s Code of Conduct. Illustrative templates should be developed for these policies.
- (5) GBV Intake Mechanism, which will detail how the Employer will receive GBV-related complaints, data- gathering in relation to the complaints, and the necessary subsequent procedures thereafter;
- (6) GBV Referral Mechanism, to which the Employer will refer GBV survivors to necessary government offices, local police, and other potential sources of further action and services;
- (7) GBV Monitoring and Evaluation Strategy, which describes the safety measures to be implemented for the benefit of monitoring the general condition of the project;
- (8) GBV Allegation Procedures; how the project will provide information to employees and the community on how to report cases of GBV CoC breaches to Grievance Redress Mechanism (GRM).

4.10.1.2 A summary of all recording, monitoring, investigation and mitigation of all gender-based violence and sexual harassment-related cases committed by the Contractor’s and Sub-Contractor’s personnel to person on and near the site.

4.10.1.3 The contractor shall adopt the Gender and Development (GAD) policy by providing the below:

- a. Conduct Ethic and Behavioral Coaching training;
- b. Provide the Gender-Based Violence (GBV) and Sexual Harassment (SEAH) Awareness and Response Training;
- c. Other relevant training that the Employer deem necessary.

4.10.1.4 The employment status shall include monitoring of above-mentioned training content compliance.

5 Safety Considerations for Design

5.1 General

5.1.1 The safety of passengers and staff is of great concern, therefore considerable attention has been paid in setting out the parameters for design to matters that can have an effect on safety and availability. This includes not only the performance of the trains, but also such matters as maintenance of tolerable environmental conditions and standby operation under emergency conditions.

5.1.2 The goal is zero harm for the passengers, staff, project partner staff and customers to prevent injury and ill health. This goal is driven by our expectations of continual improvement in all activities both in this NSCR-EX project and our project partner, based upon risk and organizational benefit.

5.1.3 Hence, the Contractor shall bear in mind the safety requirements and ensure that the

design and performance of MCRP and NSRP-South Rolling Stock and equipment maintain high safety.

- 5.1.4 The Contractor shall pay due attention to the need to safeguard the staff who shall be required to operate and maintain the MCRP and NSRP-South Line. For guidance, but without limiting the Contractor's responsibilities as to safety requirements, the principal aspects to be considered and incorporated into the Works shall include:
- a. The provision of metallic guards to all moving parts such as gears, belt drives, chain drives, interlocking mechanisms and similar items;
 - b. Notices for hazards and high voltages;
 - c. Provision for lubricating, greasing, adjusting and other maintenance facilities that can be reached without hazard; and
 - d. Identification of all equipment, wires, connectors, etc.

5.2 Materials

- 5.2.1 All apparatus, connections and cabling shall be designed and arranged to minimize the risk of fire and any damage, which might be caused in the event of fire. Wherever practicable, materials shall be used which do not support combustion and which do not give off smoke, corrosive or toxic fumes, when heated.
- 5.2.2 Materials shall be selected which provide the minimum practicable hazard, and care shall be taken to minimize the risk of the effects of any fire extending beyond the place of its initiation.

6 Common Technical Requirements for All Equipment

6.1 Standards

- 6.1.1 Where no particular national or international standard is specifically stated in the documents, the Works shall comply with the relevant standard, code, or recommendation of the following organizations:
- a. Philippines National Standards (PNS);
 - b. Japanese Industrial Standards (JIS);
 - c. The International Organization for Standardization (ISO);
 - d. The International Electro Technical Commission (IEC);
 - e. International Union of Railways (UIC);
 - f. European Norm (EN);
 - g. Rolling Stock Industrial Standard (JRIS) – Japan; and
 - h. Ministry of Land Infrastructure, Transport and Tourism (MLIT) - Japan.
- 6.1.2 The standards of the above organizations referred to herein represent the minimum requirements that shall be met. The Contractor may adopt standards of the countries of source, but he shall confirm that such standards are equivalent to or better than those either referred to in the documents or listed above. The Contractor shall submit three copies of such standards in English for the Engineer’s review, drawing attention to all differences. In the case that the Engineer does not approve such standards, the Contractor shall adopt those specified above.
- 6.1.3 It shall be understood where reference is made within these documents to certain standard specifications, the reference shall be construed to mean the standards, with all subsequent amendments, changes or additions as thereafter adopted and published that

are in effect at the date of invitation to tender.

- 6.1.4 It shall be the responsibility of the Contractor to ascertain that all relevant local laws, rules, standards, codes and regulations are strictly adhered to. Unless otherwise reviewed by the Engineer, any reference in any standard to a recommendation shall be interpreted by the Contractor as a requirement of the Employer. Also, unless otherwise reviewed by the Engineer, whenever any such standard provides for alternatives, the most stringent alternative shall apply.
- 6.1.5 The Contractor shall provide one (1) copy of all relevant manufacturing and testing standards for items under his scope of supply.
- 6.1.6 In addition to the above, all standards and codes referred to in Bid Documents to be supplied shall be new, complete and the latest version/issue. The submission shall be within thirty-five (35) days from Commencement Date of the Works in accordance with the Quality Management Plan (QMP).

6.2 Units

- 6.2.1 The International System of Units (SI Units) shall be used for measurement and design criteria for equipment, drawings and materials supplied and installed under this contract, unless given Notice of No Objection otherwise in writing by the Engineer.

6.3 Suitability of Purpose

- 6.3.1 The Rolling Stock shall be designed, and constructed to meet their particular use by the Employer. The design shall facilitate inspection, cleaning, lubrication, repairs and operation in which continuity of service is a major consideration.
- 6.3.2 All materials used shall be of the best quality and of the class most suitable for operating under the conditions specified and shall withstand the variations of environmental conditions without distortion, deterioration or undue stresses in any part, and also without affecting the strength and suitability of the various parts for the work for which it must perform. No welding, filling or plugging of defective parts shall be permitted without the approval in writing of the Engineer.
- 6.3.3 The design shall incorporate every necessary feature to ensure the safety of all those concerned in operation and maintenance.
- 6.3.4 As far as possible, the systems and equipment offered by the Contractor shall be the standard manufactured model with an appropriate documented history of reliable service and performance.
- 6.3.5 All items of systems and equipment shall be new and shall not have been in service at any time prior to delivery, except as required for testing purposes.
- 6.3.6 Corresponding parts liable to renewal shall be interchangeable. When required by the Engineer, the Contractor shall demonstrate this feature.
- 6.3.7 All apparatus shall operate without undue vibration and with the least practicable amount of noise in accordance with the requirements of the Technical Requirements. The system shall meet the overall noise limitations of the applicable Philippine Code. Equipment boxes, cubicles and similar enclosed compartments shall be adequately labelled, ventilated to restrict condensation and, where necessary, suitable integral anti-condensation heaters shall be provided.
- 6.3.8 Carbody structure and equipment to be installed on the exterior shall be so designed from stainless steel or equivalent material and equipped with adequate drain holes so as to avoid pockets in which water can collect.

- 6.3.9 Accessible means shall be provided for the easy lubrication where required of all bearings, mechanisms and moving parts. Grease lubricators shall be fitted with standard nipples.
- 6.3.10 All electrical connections and contacts shall be of ample cross section and surface for carrying continuously the maximum design current without undue heating, and shall be secured by clamps, bolts or set screws of ample size, and fitted with locking devices of approved type and material.
- 6.3.11 Surfaces subject to rubbing or wearing shall be machine finished. Joints employing a gasket material shall be so constructed that the packing is maintained under sufficient compression in all parts, so that an efficient joint can be made without the use of jointing compound. Gasket material shall be of the minimum thickness necessary and of approved composition.
- 6.3.12 All apparatus shall be designed to obviate the risk of accidental short circuit due to animals, birds and vermin. Openings in ventilation enclosures shall be so constructed to prevent entry of vermin and insects.
- 6.3.13 All apparatus incorporating hinged doors shall be provided so that the doors can be opened to at least 90 degrees or can be readily removable after adjacent equipment has been installed.

6.4 Manufacturer’s Standards

- 6.4.1 Unless specified otherwise, all materials and equipment associated with the installation shall be handled and installed strictly in accordance with the manufacturer’s recommendations and by workers who have undergone training by the manufacturer and have previous experience with the equipment and materials.
- 6.4.2 The Contractor shall ensure that his staff and subcontractors use appropriate tooling recommended by the manufacturers for the installation of their materials and equipment.

6.5 Right of Rejection

- 6.5.1 The Employer and the Engineer shall have the right to reject all material or work that is non-compliant, and require the replacement and rectification of the Works at the sole expense of the Contractor.

6.6 EMI/RFI

- 6.6.1 Electro-Magnetic Interference/Radio Frequency Interference (EMI/RFI) shall be held to a minimum commensurate with good design practices, and in no case shall signal levels be permitted which interfere with, or compromise, the operation of any of the Employer’s systems.
- 6.6.2 Test data shall be submitted indicating compliance with the latest industry guidelines. The Contractor shall demonstrate by test that electromagnetic interference levels do not exceed the current pertinent recommendations of the International Electro- technical Commission. In addition, the Contractor shall demonstrate by test that his equipment does not interfere with any of the Employer’s existing systems. Should testing prove that the Contractor’s equipment interferes with any of the Employer’s systems, as judged by the system supplier, the Contractor shall ensure modifications are carried out to the equipment to bring it into compliance with this requirement.
- 6.6.3 The Contractor is required to submit for review and approval the EMI/RFI study report which shall be prepared in accordance with IEC 62236 or equivalent.

7 Quality Assurance

7.1 Quality Management Plan (QMP)

- 7.1.1 Within thirty-five (35) days from Commencement Date of the Works, the Contractor shall submit a detailed Quality Management Plan (QMP) to the Engineer for his review and comments.
- 7.1.2 The Quality Management Plan shall define the Contractor's management structure and the quality management system for the execution of the Contract Works and shall, without limitation, define as follows:
- a. Project details including name, Contract Number;
 - b. A summary of the Project requirements including all proposed quality activities;
 - c. All Quality Assurance system details including proposed reporting and quality control procedures, proposed by the Contractor for his use in the execution of the Works;
 - d. A list of all the Codes of Practice, Standards and Specifications that the Contractor proposes to apply to his work. These shall include those that differ from or complement the requirements of the Contract or those specified in the Contract;
 - e. The Contractor's proposals for internal, subcontractor and contractor-under-subcontractor quality assurance audits, including a schedule;
 - f. A statement detailing the records that the Contractor proposes to keep, the time during which they shall be prepared and the subsequent period and manner in which they shall be indexed, prepared and stored;
 - g. Inspection and test plans for every activity requiring inspection and testing. The plans shall identify the level of inspection and testing required and shall stipulate who is responsible for releasing an activity from a "Hold Point";
 - h. The Contractor’s organization managerial staff, with particular reference to any member of a partnership, consortium or joint venture, and the main subcontractors. Organization charts shall be produced to illustrate the subdivision of the Project Works into elements for effective technical and managerial control, the reporting structure and the relationship between all parties involved;
 - i. The appointment of a Quality Assurance Manager;
 - j. The specific allocations of responsibility and authority given to managerial and technical staff with particular reference to the design and site supervision of the Project Works;
 - k. The hierarchy and structure of the overall quality system documents to be applied to the Contracts, and clearly indicating any particular documents to be followed by individual key members of the Contractor if applicable;
 - l. The Contract specific quality procedures, works instruction and/or standard forms, if applicable; and
 - m. A full list of quality procedures, works instructions, and/or standard forms, including any Contract-specific documents to be applied to the Project shall be defined. The specific ways to perform the related activities and the records to be generated shall be defined as objective evidence of the activities performed Results achieved shall be demonstrated and shall cover all the requirements of the Project including, but not limited to, the following activities:
 - i. The review, approval and updating of the quality system documents to ensure

their continuing suitability and effectiveness;

- ii. Design control for all permanent works and/or temporary Works, including design Works carried out by subcontractors and sub-consultants. The procedures shall clearly define the review and verification;
- iii. Drawing management in main office and Site office(s), including production, approval, updating, maintaining, storage and distribution;
- iv. Project document management, including registration, updating, indexing, filing, maintenance, storage and distribution;
- v. Monitoring and control of subcontractors with respect to programme, submission and quality of Works;
- vi. Monitoring of the submission and re-submission to the Engineer;
- vii. Monitoring of the ordering and delivery of materials, plant and equipment;
- viii. Quality control of the Project Works;
- ix. Quality audits on the Contractor and subcontractors of any tiers; and
- x. Establishing and maintaining a record in accordance with the Contract requirement provision.

7.1.3 The Quality Management Plan comprise of management quality, Planning Design Quality Plan Manufacturing Quality Plan (including inspection and testing) and Testing and Commission (including integrated testing and commissioning Quality Planning).

7.1.4 The QMP shall be updated as necessary from time to time to incorporate for continuous improvement, aspects, subject to Engineer review and possible change to the Contractor’s control procedures.

7.1.5 Design Quality Plan

7.1.5.1 The Contractor shall prepare a Design Quality Plan for all design Works. The Design Quality Plan shall define the Contractor's and the Designer's policy for the design works and shall, without limitation, define:

- a. The organization of the Contractor's and the Designer's design staff; Manufacturing Quality Plan, Testing and Commissioning Quality Plan;
- b. The specific allocations of responsibilities and authorities given to identified design staff or subcontractors for particular design works;
- c. The hierarchy of quality management system documentation for managing and controlling design works, including design works of subcontractors of any tier; and
- d. The list of procedures and instructions to be applied to manage and control the quality of the design works.

7.1.6 Manufacturing Quality Plan

7.1.6.1 The Manufacturing Quality Plan shall define the Contractor's management structure and quality management system for the manufacture of the key items of the Contract Works, and for the items as requested by the Engineer. Separate Manufacturing Quality Plans shall be prepared for each item of the Contract Works.

7.1.6.2 The Contractor shall prepare and maintain a full list of all the Manufacturing Quality Plans required for the Contract with submission status, and shall submit to the Engineer upon request.

7.1.6.3 Each Manufacturing Quality Plan shall define, without limitation:

- a. The scope of Works and the item covered by the plan;
- b. The organization of the Contractor and/or the subcontractor responsible for the day-to-day management of the manufacture of the item;
- c. The specific allocations of responsibility and authority given to personnel for the day-to-day management of the manufacturing activities, with particular reference to the supervision, inspection and testing of Works; and
- d. The specific methods of manufacture, including but not limited to the following:
 - i. The particulars of the material to be incorporated into the items;
 - ii. The manufacturing process in compliance with drawings and specifications;
 - iii. The identification or referencing requirements for traceability of the manufactured items;
 - iv. The identification of the inspection and test status of the materials and final manufactured items;
 - v. The disposition of nonconforming materials and manufactured items; and
 - vi. The handling, storage, packaging, preservation and delivery of the manufactured items.

7.1.7 Inspection and Test Plans

7.1.7.1 Under the Manufacturing Quality Plan, inspection and testing plans shall be produced for all activities requiring inspection and/or test.

7.1.7.2 The Contractor shall prepare and maintain a full list of all the Inspection and Test Plans required for the Project with submission and review status, and this shall be submitted to the Engineer on request.

7.1.7.3 Each inspection and test plan shall define, without limitation:

- a. The scope of activity covered by the plan;
- b. The sequence of work related to the activity covered by the plan;
- c. The personnel responsible for undertaking the inspection and/or test;
- d. The personnel responsible for certifying the inspection and test;
- e. The inspection and/or test method or a reference to the relevant standard of inspection and/or test;
- f. The frequency of the inspection and/or test;
- g. The compliance criteria of the inspection and/or test;
- h. The quality hold point and quality assurance points;
- i. The documents to be used for reporting the results of the inspection and/or test, and with examples of such documents incorporated into the Inspection and Test Plan; and
- j. The storage locations and filing of the records of the inspection and/or test.

7.2 Quality Assurance Manager

7.2.1 The Contractor shall appoint a suitably qualified and experienced full-time person as the Quality Assurance Manager to be responsible for the task of establishing the

documented quality management system and ensuring that the quality management system is implemented and maintained effectively.

- 7.2.2 The Quality Assurance Manager shall be directly responsible to the senior level of management and is able to discharge his duties without hindrance or constraint. In addition, the Contractor shall make available any such resources that are necessary to ensure the effective implementation of the quality management system.
- 7.2.3 The Contractor shall submit for review by the Engineer details of qualifications, experience, authority and responsibility of the proposed Quality Assurance Manager, as part of the Quality Organization Plan.

7.3 Quality Audits

- 7.3.1 The Contractor shall carry out Quality Audits on the Project Works at regular intervals, or at such other intervals as the Engineer may require, ensuring the continuing suitability and effectiveness of the quality management system. Reports of each such audit shall be submitted promptly to the Engineer for review.
- 7.3.2 The Contractor shall submit for review by the Engineer details of the authority, qualifications and experience of personnel assigned to quality audit activities before carrying out quality audits.
- 7.3.3 The Engineer may require quality audits on the Contractor and his subcontractors of any tier to be carried out by his representative or the Employer’s staff. In such case, the Contractor shall afford to such auditors all necessary facilities and access to the activities and records to permit this function to be performed.
- 7.3.4 Upon receipt of Corrective Action Request (CAR) or similar document issued by the Engineer as a result of quality audits, the Contractor shall promptly investigate the matter and submit the proposed corrective and preventive actions within 14 days to the Engineer for review. The Contractor shall take timely corrective and preventive actions to rectify the matter and to prevent re-occurrence. Evidence to demonstrate effective implementation of corrective and preventive actions shall be submitted by the Contractor to the Engineer for review.

7.4 Notification of Non-conformities

- 7.4.1 If, prior to issue of the Taking Over Certificate for the Contract Works or the relevant Section, the Contractor has used or proposes to use or repair any item of the Contract Works that does not conform to the requirements of the Contract, the Contractor shall immediately submit for review by the Engineer of such proposal and supplying full particulars of the non-conformity and, if appropriate, the proposed means of repair.
- 7.4.2 If the Engineer issues a non-conformity report or similar documents to notify the Contractor of any item of the Contract Works which does not conform to the requirements of the Contract, the Contractor shall promptly investigate the matter and, within 14 days of notification by the Engineer, submit to the Engineer for review the remedial measures and necessary actions to be taken to rectify the item and to prevent re-occurrence.
- 7.4.3 The Contractor shall maintain and update a non-conformity register to indicate the status of all non-conformities that are identified by the Engineer and/or the Contractor. The Contractor shall submit the register for review upon request by the Engineer.

7.5 Monthly Progress Report on Quality Management System

- 7.5.1 The Contractor shall continuously monitor the performance of the Quality Management

System and shall include in each Monthly Progress Report:

- a. The submission status and review status of the quality system documents;
- b. An up-to-date audit schedule and status;
- c. An up-to-date non-conformity register providing the status of all non-conformities identified by the Engineer or the Contractor within the reporting period and those non-conformities not yet satisfactorily closed; and
- d. A narrative appraisal of the performance of the quality system, including any non-conformities, shortcomings or problem areas identified and the corrective and preventive action taken or proposed.

7.5.2 The Contractor shall provide and maintain at all stages of the Contract Works a quality control register or registers to identify the status of inspections, sampling and testing of the work and all certificates. Such register shall be updated by the Contractor to show all activities in previous months and shall reach the Engineer’s office before the 7th day of each month.

7.5.3 Each register shall:

- a. List the certificates received for each batch of goods and materials incorporated in the Contract Works and compare this against the certification required by the Contractor and the Contractor’s quality plans;
- b. List the inspection and testing activities undertaken by the Contractor on each element of the Contract Works and compare these activities against the amount of inspection and testing required by the Contract and the Contractor’s quality plans;
- c. Show the results of each report of inspection and/or test and any required analysis of these results and compare these results against the pass/fail criteria; and
- d. Summarizes any actions proposed by the Contractor to overcome any nonconformity.

7.6 Quality Records

7.6.1 The Contractor shall ensure that all the quality records as objective evidence of the implementation of the Quality Management System are properly indexed, filed, maintained, updated and stored in an acceptable software system. These records shall be delivered to the Engineer in CD form upon completion of the Contract Works.

7.7 Information Management

7.7.1 The Contractor shall submit an Information Management Plan as part of the Quality Management Plan describing how the Contractor shall create, collect, store, search, manage and distribute information.

7.7.2 The Information Management Plan shall:

- e. Include system architecture and process to describe how the Contractor shall provide information to the Engineer in a controlled, efficient, transparent, auditable and timely manner;
- f. Contain information on workflow, metadata, Contractor’s approval process and status;
- g. Be compatible with the Contractor’s other software used on the Contract;
- h. Reference the Contractor’s Electronic Document Management System (EDMS) document management plan;

- i. Detail how data and information shall flow between the Contractor’s CAD engineering environment to the Contractor’s document control EDMS environment;
- j. Detail how assigned authority is controlled through workflows and permissions to ensure any sign-off function shall only be presented to the correct authority; and
- k. Detail how object data from the CAD Model shall populate areas in the Configuration Model.

7.8 Electronic Document Management System (EDMS)

- 7.8.1 The Contractor shall use an Electronic Document Management System (EDMS), which is compatible with the Employer’s EDMS, to coordinate and control the document flow (creation, processing, storage, retrieval and distribution) of electronic and paper documents in a secure and efficient manner.
- 7.8.2 All the Contractor’s documents shall be controlled via the EDMS system for the work under the Contract. The Contractor’s EDMS shall remain in effect during the Contract and Defects Notification Period.
- 7.8.3 These requirements cover all types of documents including, but not limited to:
 - a. management plans, procedures, method statements;
 - b. quality documentation, norms, standards;
 - c. design documents;
 - d. design models;
 - e. as-built drawings;
 - f. operation and maintenance manuals;
 - g. engineering calculations;
 - h. reports - progress, construction, test & commissioning, technical and non- technical;
 - i. time, schedules and cost; and
 - j. certification.
- 7.8.4 The Contractor’s EDMS shall:
 - a. provide a storage and backup infrastructure to prevent data loss and provide data recovery mechanisms;
 - b. provide a single, controlled source for each document;
 - c. provide an efficient search and retrieval of specific documents;
 - d. provide measures to control restricted access to programme documents and provide access to all documents to all team members;
 - e. identify document development and approval processes that promote quality and consistency;
 - f. provide clarity regarding which version of a deliverable is the latest version;
 - g. provide a clear record of deliverables;
 - h. enable quick and direct propagation of changes; and
 - i. provide an accurate and complete archive of documents to the Employer.

7.9 Electronic Document Management

- 7.9.1 The Contractor shall submit an Electronic Document Management procedure as part of the Quality Management Plan for review by the Engineer, detailing how the Contractor shall implement and maintain a web-based EDMS.
- 7.9.2 The EDMS shall give an overview of the strategy and shall include a permissions matrix mapped to roles and responsibilities, workflow, systems architecture, resilience and disaster recovery.

7.10 Software Management and Control

7.10.1 Prescriptive Framework

- 7.9.1.1 All software to be developed or modified shall follow the normative requirements of standards proposed by the Contractor. The Contractor shall define the Software Quality Assurance Management section within the Quality Management Plan what techniques and measures are to be applied for software development;
- 7.9.1.2 The section shall require the Contractor to provide all changes, bug fixes, updates, modifications, amendments and new versions of the programs, as required by the Engineer;
- 7.9.1.3 The Contractor shall provide all tools, laptop computers or any special device to upload / download the software, equipment, manuals and training necessary for the Engineer to maintain all software provided under this Contract;
- 7.9.1.4 When a fault is discovered in delivered software, or an error in the associated documentation, the Contractor shall take the necessary steps to rectify such faults and errors at the earliest opportunity. The Contractor shall supply to the Engineer, full details, in writing, as to the nature of the corrective action proposed or taken. These changes shall be documented in the form of Software Engineering Change Proposal (SECP), which shall be reviewed by the Engineer; and
- 7.9.1.5 It will be incumbent upon the Contractor to take responsibility for any changes required to the software.

7.10.2 Software Framework

- 7.9.2.1 All the software produced or supplied for the Project shall be subject to a defined quality framework. The Contractor shall use a Quality Assurance System which is compliant with ISO 9000 series and meet the requirements as stipulated in the ERG and ERT. ISO 9000-3 is considered appropriate for any software framework.

7.10.3 Software Management Control

- 7.9.3.1 The Contractor shall assign the Software Manager and Software Quality Manager for software development, if software development or modifications are required under the Contract.

7.10.4 Auditing

- 7.9.4.1 The Engineer may carry out an audit of the software. Further external independent audits may also be arranged at the Engineer discretion.

7.10.5 Software Acceptance

- 7.9.5.1 The Contractor shall also submit an Operational Safety Report (Software) for software acceptance by the Engineer.
- 7.9.5.2 The Operational Safety Report (Software) shall include, as a minimum
- a. Introduction
 - b. Shall describe the nature of software sufficiently to ensure that the Engineer is given a comprehensive overview of primary characteristics such as structure, functions, criticality, volume and language;
 - c. Evidence of Quality Management
 - d. Shall provide evidence to demonstrate that the software development has been subject to acceptable quality assurance;
 - e. Evidence of Safety Management
 - f. Shall provide evidence to demonstrate that the software development has been subject to acceptable safety management;
 - g. Technical Report
 - h. Shall describe how software integrity has been achieved;
 - i. Operation and Maintenance Report
 - j. Shall describe the software operation and maintenance characteristics; and
 - k. Restrictions for Use
 - l. Shall define what restrictions are applied to the use of the software.

7.10.6 Availability of Application Software and Development Tools

- 7.9.6.1 With the exception of commercial, off-the-shelf software, the Engineer shall be provided with access to full software documentation listings and development tool details for the application and maintenance of that software. For such commercial software, the Contractor shall provide all available documentation for the application and maintenance of that software;
- 7.9.6.2 Complete documentation along with the software to be supplied by the Contractor, as above, shall comprise of signal flow diagram, detail of signals, interpretations so as to enable the Employer to debug and implement the parameter of the system, if considered necessary. The Employer’s engineers shall be fully trained and made conversant with the software and other related issues as found necessary during the Contract execution to enable the Employer to operate, maintain, repairing system efficiently; and
- 7.9.6.3 After loading, and the satisfactory functioning of the software, the Contractor shall supply two back-up copies of the software, including any new versions adopted.

7.10.7 Re-Use of Existing Software

- 7.9.7.1 Where existing software (defined to module level) is to be re-used without modification, the Contractor shall provide acceptable evidence to the Engineer as to why that software is suitable for use in the proposed application. This evidence may be historical (certified evidence of previous satisfactory use in a similar environment and application), or it may be sought as cross acceptance from another railway authority or statutory body. Software re-use shall not be acceptable, without detailed review, where the proposed application is of the same or lower safety than the current application.

7.10.8 Test Software

7.9.8.1 All test software, with the exclusion of built-in test software, shall be produced in accordance with a quality system controlled under the requirements of accepted international standards. Test software shall be developed and documented using structured techniques and shall be designed to be maintainable throughout the duration of the Contract. All test software shall be documented to be supportive of maintenance. Any test software, which is to be delivered to the Engineer (for long term testing use), shall be fully documented including source code listings to allow the Engineer to maintain the software for the life of the supported system.

7.10.9 Software Rights

7.9.9.1 The Contractor shall ensure that the Employer/the Engineer or its licensee is granted all necessary rights to use software embodied in the equipment and there are no restrictions attached to the use of any information supplied by the Contractor which might later prevent or hinder the Employer/the Engineer or its licensee from modifying or adopting or extending the system. The Contractor shall indemnify the Employer/the Engineer, its heir or licensees against the claim of any party, subcontractor for the unauthorized possession or use of the software supplied.

7.10.10 Security

7.9.10.1 The Contractor shall define the procedures to maintain the security of the software. Aspects to be considered include:

a) Sabotage

The Contractor shall describe what measures are to be taken to protect the software against sabotage during the development phase. This description shall define the physical restrictions as well as procedural measures and specific tests to be carried out on the software.

b) Unauthorized Access

The Contractor shall describe what measures are to be taken to protect the software against unauthorized access and subsequent modification. The description shall define both physical and procedural methods.

c) Virus

The Contractor shall ensure software, which is susceptible to viruses, is developed in environment certified free from computer viruses. To achieve this, the Contractor shall use propriety virus detection software and suppression tools.

7.9.10.2 All software delivered to site shall be accompanied by evidence that demonstrates the media is free of viruses.

7.10.11 Security Obligations

- a. Within 14 days of the installation of any safety critical software or software which may impact the train operation, into the Works, the Contractor shall deposit the software in the escrow account, which shall include, without limitation:
 - i. All design documentation relating to the software; and
 - ii. Any specified development tools required for maintenance of the software, including, but not limited to, editors, compilers and linkers.

- b. The access to the above-mentioned escrow account shall be given to the Employer for him to translate or modify the software in case of:
 - i. The owner of the software becomes insolvent or has a receiving order made against them or makes an arrangement or assignment or composition with or in favour of its creditors (including the appointment of a committee of inspection) or goes into liquidation or commences to be wound up or has a receiver, liquidator, trustee or similar officer appointed over all or any part of its undertaking or assets or if distress, execution or attachment is levied on, or if another party takes possession of, any of its assets or any proceeding or step is taken which has an effect comparable to the foregoing in any relevant jurisdiction; or
 - ii. The owner of the software ceases to trade; or
 - iii. The owner of the software assigns copyright in the software and the Contractor fails within 60 days of such assignment to procure in favour of the Employer, a license from the new owner in the same terms as that required by the Contract; or
 - iv. The Contractor is in breach of any of his obligations under the Contract.
- c. The cost of opening and maintaining the escrow account until end of the DNP shall be borne by the Contractor.

7.10.12 Software Documentation

- 7.9.12.1 The documentation of software shall be supplied to the Engineer/Employer before the completion of the DNP.

7.11 Quality Organization

- 7.11.1 The Contractor shall submit a detailed organization chart. It shall identify the responsibilities, authority and interrelation of all personnel who manage, perform and verify items affecting quality system and the Works. The organization chart shall be specific only to this Contract.
- 7.11.2 The chart shall identify the quality management representative who shall act as the quality coordinator(s) for the Contractor in all dealings with the Engineer.

7.12 Identification and Traceability

- 7.12.1 The Contractor shall produce and maintain procedures for identifying the product from applicable drawings, specifications and other documents during all stages of production, delivery and installation. Traceability of materials and equipment shall be documented in accordance with the Contract and the QMP.
- 7.12.2 Notwithstanding the requirements of the Contractor's quality system, the Contractor shall retain all inspection certificates, test certificates and certificates of conformity, which shall be collated to allow easy traceability and made available for inspection by the Engineer at the Contractor's premises.

7.13 Quality Audit

- 7.13.1 The Contractor shall make available on request any documents, which relate to their recent internal audits.

- 7.13.2 Periodically during the life of the Contract, the Engineer shall conduct compliance audits of the quality system. During any audits by the Engineer, the Contractor shall provide qualified staff to accompany the auditor.

8 System Assurance

8.1 General

- 8.1.1 System Assurance Management is applicable for all stages of the Rolling Stock development, including design, manufacture, testing, commissioning, systems integration, trial operations, and in-service operations.
- 8.1.2 The Contractor shall submit a comprehensive System Assurance Management Plan (SAMP) which contains all requirements within this ERG Section 8 of this document, for the Engineer’s review.
- 8.1.3 The SAMP shall also include a configuration management tracing system. This system shall be in place throughout the contract to ensure that all deliverable items of equipment are of the same configuration. All changes to equipment and configuration change control process shall include the phases of configuration identification, control of change and configuration verification.
- 8.1.4 The SAMP shall be certified by the Contractor’s internal department or by a third-party independent engineer from the design and manufacturing section. The SAMP shall be specifically developed for this Contract. The SAMP shall address the Performance (Reliability, Availability, Maintainability) and Safety of the Rolling Stock.
- 8.1.5 A Taking Over Certificate (TOC) will be issued for each train set. In order to obtain a TOC for the Rolling Stock from the Engineer, it is required that each train set achieves 1,500 km of Fault-Free Running (FFR) during system integration and trial operations.
- 8.1.6 A Performance Certificate will be issued by the Engineer for the total performance of the fleet. This Performance Certificate is required to be achieved by the end of the Defect Notification Period (DNP). Prerequisites to obtain the Performance Certificate includes: each train set shall achieve 10,000 km or 2 months of FFR, the fleet (38 train sets) shall achieve a Mean Distance Between Failures (MDBF) of 50,000 km causing a delay greater than 5 minutes, a fleet in-service Operational Mean Time To Restore (OMTTR) of 15 minutes, and the fleet maintainability of capital components a Corrective Mean Time To Repair (CMTTR) of 4 hours.
- 8.1.7 The Contractor shall provide sufficient documented information for review by the Engineer. It is expected that the design demonstration of the Rolling Stock performance shall be achieved through supplier-based material self-certification, including cross-references to proven and accredited in-service performance of Rolling Stock equipment supplied in a similar railway application.
- 8.1.8 The Contractor shall establish a Data Reporting and Corrective Action System (DRACAS) to monitor the performance of the equipment, from testing and commissioning and into operation. The system shall be used to monitor the performance of components and to identify patterns of failures so that corrective action can be taken to improve both current and future systems.
- 8.1.9 With regard to Safety, it is expected that certification shall be achieved through supplier-based information via application of cross references to previously certified acceptances from a reputable body (e.g., train operators, national railways authorities, independent accredited safety bodies, etc.) of similarly supplied Rolling Stock equipment, with a product-generic safety case application to be made based on existing safety certification.

8.2 Performance Assurance Plan (PAP)

- 8.2.1 Within the SAMP, the Contractor shall provide a Performance Assurance Plan (PAP) for the Engineer’s review. The PAP shall describe the activities that the Contractor proposes to carry out during the life cycle of the design, implementation and operation of the Rolling Stock, and shall demonstrate compliance with the Employer’s Requirements, achievement of a TOC for each train set, and a Performance Certificate for the total fleet (38 train sets).

8.2.2 Performance Acceptance Criteria (PAC)

- 8.2.2.1 Each train set shall achieve:
- a. **Trial operations** – 1,500 km FFR.
 - b. **In-service Operations** - 10,000 km or two (2) months of continuous in-service operational FFR.
- 8.2.2.2 The train fleet (38 train sets) as a whole shall achieve:
- a. **MDBF** – In service operational faults, MDBF no less than 50,000 km causing a delay greater than 5 minutes.
 - b. **OMTTR** – Operational Mean Time To Restore (OMTTR) capital components; the train sets shall be restored to operational order in an OMTTR of 15 minutes.
 - c. **CMTTR** – Corrective Mean Time To Repair (CMTTR) capital components shall not be greater than 4 hours.

8.3 Performance Reports

- 8.3.1 The Contractor shall provide Performance Reports to support the applications for Rolling Stock TOC for each train set and the Performance Certificate for the fleet (38 train sets).
- 8.3.2 The Rolling Stock TOC Performance report shall be issued for each train set prior to operational acceptance and shall provide:
- a. Technical design justification of performance;
 - b. Cross reference to Rolling Stock performance in a similar application;
 - c. The design prediction for MDBF, OMTTR and CMTTR of all capital components; and
 - d. Individual train set FFR trial operations performance.
- 8.3.3 The Rolling Stock Performance report shall be issued progressively on a monthly basis, shall be finalized at the end of DNP, and shall provide:
- a. In-service FFR operational performance of individual train sets;
 - b. In-service operational performance of the fleet (38 train sets) MDBF; and
 - c. The in-service OMTTR and CMTTR of all capital components

8.4 Performance Certificate

- 8.4.1 During the in-service Defects Notification Period (DNP), the fleet (all 38 train sets) in total shall demonstrate successful achievement of the Performance Acceptance Criteria (PAC) which will be a prerequisite of the application for a Performance Certificate to be issued by the Engineer.
- 8.4.2 Failure to meet the PAC within the DNP shall mean that the DNP shall be extended until

such time as the PAC of the total fleet has been met.

- 8.4.3 The DNP shall be up to a limit of 4 years from the date of commencement of the first train in-service operation.

8.5 Safety Assurance

8.5.1 Safety

8.5.1.1 Safety is defined as freedom from those conditions that can cause death, injury, occupational illness, or damage to or loss of equipment or property. All circumstances susceptible to cause injuries or fatalities of passengers, operation staff, and maintenance staff are considered as risks, and by extension, includes all events leading to a partial or total destruction of costly equipment. The objective of safety is expressed by the capability of the Rolling Stock to keep the physical integrity of the asset and to preserve the safety during railway operations and maintenance for passengers, staff and persons in general. The safety assurance program aims to reduce to a tolerable level the probability of occurrence of catastrophic or critical events causing damage to assets or harm to any person.

8.5.1.2 The Contractor shall bear the duty of safety in design for the assurance of safety for the life cycle of MCRP and NSRP-South operations. The Rolling Stock shall fulfil the safety requirements of all General Requirements and Technical Requirements and shall demonstrate that the train is fit for purpose to be operated and maintained in a safe manner for the MCRP and NSRP-South project.

8.5.2 Safety Assurance Plan (SAP)

8.5.2.1 Within the SAMP, the Contractor shall provide a Safety Assurance Plan (SAP) for review by the Engineer. The SAP shall cover the design, manufacture, testing, commissioning and integrated testing phases, and safety management for in-service passenger operations. The Plan shall further identify how the magnitude and seriousness of events or malfunctions which could result in harm to passengers or staff and damage to equipment or property will be minimized.

8.5.3 Safety Report

8.5.3.1 The Contractor shall carry out Safety Assurance and provide Safety Reports to the Engineer to support the Rolling Stock safety application, in coordination with the Operator, to gain a TOC from the Engineer, and a final in-service safety report to support the Performance Certificate application.

8.5.3.2 The Rolling Stock Design Safety report shall provide:

- a. Technical Justification for Rolling Stock safety; and
- b. Cross reference to a generic Rolling Stock safety application of similar product provided.

8.5.3.3 The Rolling Stock Operational Readiness Safety report provided for each train set at their TOC shall provide:

- a. The Safety application for in-service operations; and
- b. The Safety Management System to be applied for in-service operations.

8.5.3.4 The Rolling Stock In-service Final Operational Safety reports shall be issued progressively on a monthly basis and finalized at the end of DNP, they shall provide:

- a. Safety performance; and

- b. Safety recommendations.

6.2.1.1

8.6 Independent Assessment

- 8.6.1 The Employer may appoint independent engineers and/or Independent Safety Assessors (ISAs) to assess on compliance with contract requirements on System Assurance. The Contractor, subcontractors and suppliers shall provide assistance to the appointed engineers and assessors, as required.
- 8.6.2 The independent assessor may undertake the following:
 - a. Safety audits;
 - b. Design reviews;
 - c. Witnessing of testing activities;
 - d. Review of the safety and quality organizational activities;
 - e. Review of the safety processes;
 - f. Assessment of safety applications; and
 - g. Provision of safety recommendations to the Employer.

9 Contract Procedures

9.1 Management of the Contract

- 9.1.1 On or before the commencement of the Works, the Contractor shall prepare and submit for review by the Engineer, details supplemented by diagrams as necessary, of the organization which he proposes to adopt for the management of the Contract. The details shall cover all aspects of the Contract and the function, responsibility and authority of each person represented shall be defined.
- 9.1.2 Prior to their commencing work on the Contract, the Contractor shall submit for review by the Engineer, names, qualifications and experience of all the key personnel in their organization.
- 9.1.3 Any changes or additions either to the organization or to key personnel shall be subject to review by the Engineer.

9.2 (Not used)

9.3 Design Submission and Review Procedure

- 9.3.1 The Contractor shall transmit all submissions to the Engineer as required under the Contract and shall establish and implement a comprehensive Digital Electronic Information Management System at their own cost as given Notice of No Objection by the Engineer to suit the Project requirements for the transmittal of formal correspondence, documents, drawings and information and ensure efficient information management on the Project including the tracking of Progress with user friendly Monitoring, Tracker Modules, Dash boards, Triggers and reminders throughout the project life from Design stage to Testing & Commissioning and trial run.

9.4 Submission of Information – General

- 9.4.1 The Contractor shall submit to the Engineer, designs, general arrangement and detail drawings, specifications, reports and other technical literature, method statements,

calculations, schedules, programs, samples, patterns and models for review in accordance with the requirements of the Contractor's final time schedule.

- 9.4.2 The Contractor shall be responsible for the completeness of all information submitted.
- 9.4.3 The Contractor shall submit his designs for the works to the Engineer for review. The design shall be submitted in the following stages as stated in Sub-Clause 22.2 of the Technical Requirements:
- a. Conceptual design;
 - b. Preliminary design; and
 - c. Final design.

9.5 Submission of Information for Review

9.5.1 Drawings, diagrams, specifications, calculations, technical details, reports, method statements, technical literature, schedules and all other documents submitted by the Contractor for review shall comply with the following:

- a. The drawings, diagrams, specifications, calculations, schedules and all other documents shall be complete, duly signed and of good legible quality;
- b. Drawings and diagrams shall be submitted on "A" series sheets. Drawings shall be titled, numbered and dated;
- c. All specifications, calculations, schedules and documents shall have a front cover sheet stating the title, date and document reference number;
- d. When schematics or diagrams are submitted, they shall be accompanied by all of the necessary supplementary information to describe the function and operation of the equipment;
- e. When drawings, diagrams, specifications, calculations, schedules and other documents are revised and/or resubmitted for review approval, all the revisions shall be clearly defined and located on all copies, and the document reference number shall contain a revision letter or number. The letter accompanying the drawings shall list the following information in tabular form:
 - i. The drawing number, including the current revision letter or number;
 - ii. The drawing title;
 - iii. A brief description of the latest revision; and
 - iv. The reference number of the Engineer’s letter, to which the revisions correspond.
- a. The Contractor shall issue to the Engineer six (6) prints of each drawing and a copy of the electronic files. The electronic format shall be as given Notice of No Objection by the Engineer, but must allow the Engineer to clearly document future changes;
- b. The Contractor shall provide to the Engineer six prints of all networks and programs and a copy of the electronic files. The electronic format shall be as given Notice of No Objection by the Engineer; and
- c. If original text of any technical literature provided by the Contractor is not in the English language, the Contractor shall submit an unofficial but accurate English translation of the text.

9.5.2 Detailed manufacturing drawings shall not be required for review, but shall be made available for examination or shall be submitted for comment if the Engineer so requires.

9.5.3 Nothing in the foregoing shall preclude the Engineer from requiring the Contractor to submit any further design, drawings, specifications, calculations, schedules, samples, patterns or models in connection with the Contract, or to explain any point of design, installation, operation or maintenance of the equipment.

9.6 Review of Drawings, Documents and Other Information

9.6.1 Based upon the final time schedule, the Contractor shall allow for a period of twenty-one (21) days from the date of receipt of submittals by the Engineer to the issue of his comments.

9.6.2 Any action taken by the Contractor to proceed with any part of the Works before the drawings are reviewed by the Engineer shall be entirely at the Contractor’s risk, and any subsequent addition or modification to the Works requested by the Engineer shall be carried out by the Contractor at his own expense.

9.6.3 The Contractor shall also submit to the Engineer any further detailed drawings the Engineer may reasonably require of any components or equipment, in order to assess the design and its compliance with the Contract.

9.6.4 The Engineer shall respond in one of the following four ways:

- a. Category A - No Comment;
- b. Category B - Comments as Noted;
- c. Category C – Resubmission; and
- d. Category D – For Information Only.

9.6.5 Definition of the Engineer’s Responses:

9.6.5.1 **Category A - “No Comment”**; Where the Engineer has no comment pursuant to review of a submission, the Engineer shall so notify the Contractor.

9.6.5.2 **Category B - “Comments as Noted”**; If, following review of the submission, the Engineer discovers discrepancies, deficiencies, omissions or the like that are not of a critical nature, the Engineer shall respond to these comments with proposals on how they shall be addressed. Following the issue of “Comments as Noted” by the Engineer, the Contractor is entitled to proceed to the next stage of the related works subject to the inclusion of amendments necessary to address the comments. No issue of a notice of “Comments as Noted” concerning a Contractor’s document or a sample shall be a ground for extension of time or claim for additional cost.

9.6.5.3 **Category C - “Resubmission”**; The Engineer may provide comments with reasons to the Contractor that the Contractor’s document or sample in its current form does not comply with one or more of the requirements of the Contract. Such comments shall be addressed by resubmission of the Contractor’s documents or sample at the current stage before proceeding with any of the related works. In its response to the comments, the Contractor shall advise which elements of the Contractor’s document or sample it intends to resubmit. No review or comment provided by the Engineer - or the absence of review or comment – shall be construed as derogation of the Contractor’s responsibility for fulfillment of the requirements of the Contract. No request for “Resubmission” of a Contractor’s document or a sample shall be a ground for extension of time or claim for additional cost.

9.6.5.4 **Category D – “For Information Only”**: for submittals of Contractor’s documents that do not require the Engineer’s consent.

9.6.5.5 The Contractor shall be responsible for preparing and keeping up to date a contract drawing list showing the numbers and titles of each drawing and the current status of

approval by the Engineer. Two copies of the whole list shall be sent to the Engineer at monthly intervals. Copies of revised pages of the list shall be distributed whenever a drawing is revised and resubmitted.

- 9.6.5.6 Following approval of drawings, the Contractor shall issue to the Engineer six (6) prints of each drawing given Notice of No Objection and a copy of the electronic files. The electronic format shall be as given Notice of No Objection by the Engineer, but must allow the Engineer to clearly document future changes.
- 9.6.5.7 No approval by the Engineer shall absolve the Contractor from any of their duties, responsibilities or liabilities under the Contract.

9.7 Employer's Plant, Equipment and Property

- 9.7.1 Plant forming part of the Works may be used by the Contractor only with the approval of the Employer and if so used, the Contractor shall be responsible for restoring it to an 'as new' condition before carrying out the completion tests.
- 9.7.2 The Contractor shall be responsible for the protection, watching, lighting and safe custody of all plant, equipment and property being used by the Contractor for the Works or left on the Site.
- 9.7.3 If and when such plant or equipment is loaned free of charge to the Contractor by the Employer, the Employer shall reserve the right to provide operators, attendance, fuel and lubricants together with routine maintenance required for the operation of the plant or equipment. If the equipment is not self-propelled, the Contractor shall be responsible for the collection and transportation of the equipment to and from the Site.
- 9.7.4 If and when the Employer’s plant or equipment is hired to the Contractor, the Contractor shall be required to enter into a formal agreement setting out the conditions of hire.
- 9.7.5 The Employer shall not accept liability for any loss or damage caused or alleged to be caused to the Contractor in the event of breakdown or non-availability of any plant, equipment, etc.

9.8 Minimizing Nuisance and Disturbance

- 9.8.1 All work on Site shall be carried out in such a manner as to minimize nuisance and disturbance to others working on the Site, or to persons outside the Site, from smoke, fumes, noise, vibration, discharge of water from the Site or from any other cause.
- 9.8.2 All plant and equipment used by the Contractor on the Works shall be effectively attenuated by means of efficient silencers, mufflers, acoustic linings, shields, acoustic enclosures or screens. Plant and equipment shall be maintained in good order and operated to minimize noise emissions. Plant and equipment shall be sited, as far as practicable, away from adjacent occupied buildings.
- 9.8.3 The provisions shall not be applicable in the case of emergency work necessary for the saving of life or property, or the safety of the Works.
- 9.8.4 Truck loading, unloading and hauling operations shall be conducted so that noise is kept to a minimum.

10 Project Implementation

10.1 Project Management

10.1.1 Project Management Plan

- 10.1.1.1 The Project Management Plan, to be prepared by the Contractor, shall be submitted

within 28 days following the Commencement Date, to the Engineer for review, and shall conform to the minimum requirements specified below. It shall clearly demonstrate the integration of all entities which comprise the Contractor and any Subcontractors of the Contractor into one management structure.

10.1.1.2 The Project Management Plan shall contain an overview or document tree showing in schematic form, supplemented as necessary by text, how the various other Contractor’s management plans interrelate. This schematic overview shall show the titles of the various Management Plans and the main headings of the contents.

10.1.1.3 The Project Management Plan shall reference, and where necessary be referenced in, the various other Contractor’s management plans in order to provide an integrated set of documents containing all that is necessary to manage the Project and achieve the requirements specified in, or reasonably inferred from, the Contract.

10.1.1.4 The Project Management Plan shall describe the procedures, practices, and sequence of activities necessary to fulfill the requirements. As a minimum, the Project Management Plan shall include:

- a. Scope of the Plan;
- b. References to all requirements relevant to the scope of the Plan;
- c. Organizational chart(s) identifying the parties involved, their roles, main tasks and the responsibilities of key personnel;
- d. Descriptions of what is to be done, how, by whom, with what and by when;
- e. Definition of the interfaces within the team, including interfaces between design, construction, sub-contractors and suppliers;
- f. Description of the interrelationships with other contractors employed for the MCRP and NSRP-South Project;
- g. Description of the interrelationships with other third-party contractors that shall interface with the MCRP and NSRP-South Project; and
- h. Description of what records are to be produced, when, by whom and how these records are to be controlled and maintained.

10.1.2 Communication (Internal and External)

10.1.2.1 Procedures and guidelines for communications both internal to the Contractor’s organization and externally with the Engineer, statutory authorities, utility owners, third parties, and other contractors and suppliers employed by the Employer for implementation of the MCRP and NSRP-South Project shall be incorporated in the Contractor's Project Management Plan and shall include, but not be limited to:

- a. A distribution structure which details to whom information shall flow and what methods shall be used to distribute various types of information. This must be compatible with the responsibilities and reporting relationships outlined in the Contractor’s organizational chart; and
- b. Plans and procedures for communication between the Contractor and third-party stakeholders with respect to statutory permits and approvals.

10.1.3 Contract Directory

10.1.3.1 The Contractor shall establish and maintain a contract directory containing the following information for its organization:

- a. Full name, title and postal address;

- b. Telephone number(s); and
- c. Corporate email address(es).

10.1.3.2 For the Contractor’s key personnel:

- a. Full name and title;
- b. Individual telephone number and mobile telephone number; and
- c. Individual email address.

10.1.3.3 For the Contractor’s main sub-contractors and suppliers:

- a. Scope of work;
- b. Full name, title and postal address;
- c. Telephone number(s); and
- d. Email addresses.

10.1.3.4 For the key personnel of the main Sub Contractors and Suppliers:

- a. Full name and title;
- b. Individual telephone number and mobile telephone number; and
- c. Individual email address.

10.1.3.5 The Contractor shall notify its contract directory to the Engineer within 28 days of the Commencement of the Works and shall keep the Engineer informed of any changes thereto. Within 14 days thereafter, the Engineer shall notify to the Contractor the names, title and contact details of the authorized representatives of the Engineer and the other Contractors engaged on the MCRP and NSRP-South Project, by submission of the Employer’s Project directory.

10.1.4 Inception Report

10.1.4.1 An Inception Report shall be submitted by the Contractor to the Engineer within 30 days following the Contract kick-off meeting convened by the Engineer, and shall identify any critical activities to be initiated within the following 90 days.

10.1.4.2 The report shall include as a minimum:

- 1) Requests for any additional information and/or clarifications required by the Contractor which have not been provided in any of the documents that comprise the Contract;
- 2) Identification of the preparation activities planned by the Contractor to facilitate the design process;
- 3) Identification of activities in connection with the provision of design input to the utility companies;
- 4) A provisional schedule of initial organizational meetings between the Employer and the Contractor;
- 5) Identification of any issues which may threaten the planned progress of the Works during the next 90 days;
- 6) A list of contacts and/or meetings with LGUs, other statutory authorities and/or third parties for the next 90 days; and
- 7) The first three-monthly rolling program.

10.1.4.3 The Contractor may issue supplements to this report if the need for additional data is recognized within 30 days following submission of the report.

10.1.5 Liaison with Others

10.1.5.1 Approvals from Government Authorities and Agencies

The Contractor shall make all necessary arrangements with and obtain all necessary approvals from Government departments, utility agencies and other relevant/competent authorities.

10.1.5.2 Meetings with Government Departments and Agencies

When the Contractor arranges meetings with external interfacing parties, including Government departments and utility undertakings or interface contractors, it shall inform the Engineer at least four (4) official working days (excluding general holidays) or such shorter period permitted by the Engineer, before they are to be held and shall give the Engineer and the Employer the agenda and objective of the meetings.

10.1.5.3 Correspondence with Government Departments and Agencies

Copies of correspondence received from or dispatched to Government departments, utility undertakings, and interface contractors shall be submitted to the Engineer for information within two (2) days of receipt or dispatch.

10.1.6 Reporting

The Contractor shall prepare and submit all types of reports if necessary or as required by the Employer.

10.2 Contract Programs

10.2.1 Programming Software and Structure of Programs

10.2.1.1 Programming software to be used shall be Primavera P6 (Release 8.2 or later). The program submission shall be in both hard copy and soft copy. All Programs shall be prepared in terms of durations of days and weeks from the Commencement. “Day” used throughout the contract shall mean “calendar day” and “Week” shall mean “calendar week”. All programs shall be developed as critical path networks, and the Critical Path shall be clearly shown in the bar charts or networks. All programs should be submitted with standard Activity Reports (showing Times, Floats etc.) and Narrative statements, explaining the programs.

10.2.1.2 During the initial mobilization period, the Contractor shall provide the Engineer with two (2) complete sets for each of these software packages together with all documentation, standalone licenses and maintenance contracts covering the full duration of the Project from Commencement Date to the issue of the Performance Certificate. The Contractor shall arrange the installation of these software packages as directed by the Engineer.

10.2.1.3 All programs shall be developed by computerized Critical Path Method (CPM) network using the Precedence Diagramming Method (PDM) and shall be presented in both bar chart and time-scaled network diagram format, suitably colored to enable easy reading. Critical path shall be clearly marked on the bar charts and networks. Cost and resource loading will be done on the program only if the Engineer asks for it. All programs shall be submitted with standard activity reports (showing times, floats etc.) and narrative

statements, explaining the programs.

- 10.2.1.4 The narrative shall be a description of the order of procedure in which the Contractor proposes to carry out each main item of work. Personnel schedules and equipment schedules shall be prepared showing the complement of personnel and equipment proposed for the execution of the Works.
- 10.2.1.5 The critical path shall be clearly marked on the bar charts and networks. Cost and resource loading shall be indicated in the programs where required by the Engineer.
- 10.2.1.6 All programs shall be submitted in hard and soft copies.

10.2.2 Contractor’s Mobilization Program

- 10.2.2.1 No more than 30 calendar days after the Commencement of the Works, the Contractor shall submit a mobilization program to the Engineer for his review.
- 10.2.2.2 The program shall include a schedule noting the anticipated arrival of all Railway System construction equipment and facilities as well as the arrival of all of the Contractor’s and subcontractor’s key personnel.
- 10.2.2.3 The mobilization program shall include a layout plan noting the location, size and arrangement of all temporary facilities for the Contractor, including Site office, stores, security fencing, entrance and exit gates, sewage and water lines systems, electrical supply, access and facility roads.
- 10.2.2.4 The program shall clearly list all activities requiring the Engineer input and reflect any agreements regarding responses outside the standard 30-day response time.
- 10.2.2.5 The program shall include but not be limited to mobilization of staff, procurement of facilities, information required from the Engineer and deliverables to be submitted.
- 10.2.2.6 A narrative that clearly states any assumptions made by the Contractor, any items that the Contractor identifies as being at risk and any action required to be undertaken by the Engineer shall support the mobilization program.

10.2.3 Design Submission Program

- 10.2.3.1 The Contractor shall prepare the Design Submission Program, developing it from the tender submission, which is to set out fully the Contractor's anticipated program for the preparation, submission and review of the design packages, the final design submission and the installation and manufacturing drawing submissions and for the issue of notices in relation thereto.
- 10.2.3.2 The design submission program shall:
 - a. Be consistent with and its principal features integrated into the Detailed Works Program, and show all relevant major activities;
 - b. Identify dates and subjects by which the Engineer’s decisions shall be made;
 - c. Make adequate allowance for periods of time for review by the Engineer;
 - d. Indicate the design interface and coordination periods for each Interface Contractor;
 - e. Include a list of requisite design details for each and every component or equipment of all systems; and
 - f. Show the development, submission and review by the Engineer of all commissioning, maintenance, operations and training manuals and spare parts lists required by the Contract.

10.2.3.3 The Contractor shall update the design submission program suitably if the Engineer observes any deviation.

10.2.3.4 For system and components of the Works or the plant, the Contractor shall submit documents and drawings describing function description, product description, interface requirement description, RAM requirements description, life cycle calculations, type & routine test specifications, list and details of spares, related calculations, etc. The design submission program shall also include a listing of various plans, processes and other submissions.

10.2.4 Detailed Works Program (Project Implementation Program)

10.2.4.1 Within 28 days from the Commencement of the Works, the Contractor shall submit to the Engineer for review, a detailed Works program that includes, but is not limited to the following:

- a. A PERT/CPM network diagram of all activities involved in the execution and completion of the works within the time for completion, identifying the critical path;
- b. A time-sequenced bar chart based on the PERT/CPM diagram with the progress S-Curve super-imposed thereon, indicating the monthly progress estimates of accomplishments for every pay item in terms of percentages or quantities;
- c. An updated construction methodology which shall embody a narrative description of the order of procedure in which the Contractor proposes to carry out each main item of work;
- d. An updated Contractor's organization charts including:
 - i. A structural chart showing the hierarchical order of personnel the Contractor shall assign for supervision of the execution of the Works; and
 - ii. Functional chart showing the respective duties, roles, etc., of every aspect of the chart.
- e. A personnel schedule versus time showing the complement of personnel proposed for the execution of the Works;
- f. An equipment schedule over time showing the complement of equipment for the execution of the Works;
- g. A cash flow of payment schedule showing a detailed cash flow estimate, in monthly and quarterly periods, of all payments the Contractor shall be entitled to receive under the Contract; and

10.2.4.2 The detailed works program shall show, inter alia, the following:

- a. All procurement items including lead times and delivery times and dates;
- b. Manufacturing activities indicating the relationship and duration of the activities necessary to procure, fabricate/manufacture, assemble equipment / complete car tests, shipping and delivery in time to support the activities on Site; establishing Schedule of Prices for monitoring the progress of the manufacturing process. The activities shall also cover works of subcontractors as appropriate, including testing;
- c. The assembling section showing the construction of the car body, piping and wiring, installation of equipment and furnishing of the interior;
- d. The Testing section shall show individual car tests and train consist tests;
- e. Testing, commissioning and acceptance: the factory and on-site testing and commissioning activities shall present the relationship and duration of those items

- relating to commissioning tests including those related to the interface contractors. (the activities shall present the testing approach and sequence to be used, the deployment of resources in accordance with Key Dates);
- f. Integrated testing: The integrated testing activities indicating the activities required to verify the functioning of the Rolling Stock in conjunction with activities of the interface contractors;
 - g. Trial Runs: After completion of commissioning, the Contractor shall be required to take part in trial runs with other interface contractors as decided. The activities shall indicate tests, measurements and interface tests required to be carried out to verify system performance and readiness for revenue service;
 - h. Times allowed for review of submissions especially where the Engineer or Contractor has to liaise with other parties;
 - i. The dates by which the Contractor requires information from the Engineer and/or interface contractor(s) (if any);
 - j. The dates by which the Contractor requires instructions from the Engineer to carry out work described in the Contract under Provisional Sums;
 - k. The delivery periods and dates of arrival on Site of all major plant and materials and their relationship with any climatic or hydrological constraints; and
 - l. The dates and periods during which the Contractor shall enter onto Sites allocated to other contracts for execution of its Works (if applicable).

10.2.5 Detailed Works Program Updating and Revisions

- 10.2.5.1 The Contractor shall revise the initial reviewed (Baseline) detailed Works program and re-submit at intervals as required under the Contract or as directed by the Engineer; however, the period between such updates shall not exceed one month.
- 10.2.5.2 In addition, the Contractor shall immediately advise the Engineer of any proposed changes in the program.
- 10.2.5.3 Revised changes in the program shall show all operations of each major item of work from the time of commencement to the anticipated completion date, thereby indicating the periods during which work was previously underway as well as estimated future periods of design/manufacture/construction operations.
- 10.2.5.4 Each revised program shall indicate time periods ahead or behind the schedule for both completed activities and future activities, relative to the baseline program. The revised program and supporting report shall describe the revised methods which the Contractor proposes to adopt in order to expedite progress and complete within the time for completion.
- 10.2.5.5 No revisions shall be made to the completion date, except as formally instructed by the Engineer through a variation order.

10.2.6 Three-Monthly Rolling Program

- 10.2.6.1 Within 15 days from the commencement of the Works, the Contractor shall submit to the Engineer for review an initial Three-Monthly Rolling Program. The initial submission shall show in detail all activities that have commenced or are due to start within the first three-calendar-month period to meet Key Dates and any other dates set out in the Contract. Thereafter, the Contractor shall submit a new three-monthly rolling program every month as part of the Monthly Progress Report.

10.2.6.2 The Three-Monthly Rolling Program shall after the initial submittal:

- a. provide details of all activities that are in progress, or are due to start, within the forthcoming two-month period (the previous one-month period shall also be shown);
- b. be updated every month and be submitted concurrent with the monthly progress report;
- c. highlight all required dates for transmittal or receipt of information to or from the Engineer, sub-contractors or interfacing parties; and
- d. consist of a three-month time window extracted from the detailed works program.

10.2.7 Three-Weekly Rolling Program

10.2.7.1 Prior to the start of the site mobilization and each week during the construction and testing and commissioning phases, a time-scaled Three-Week Rolling Program shall be prepared and submitted to the Engineer for each section of the Works. The Three-Weekly Rolling Program shall show in detail the current week's progress, and the following two weeks' plan. The program shall clearly tie into the Three-Monthly Rolling Program in all respects.

10.2.7.2 The activities shown on the Three-Weekly Rolling Program shall be an amplification of and compatible with the latest version of the Three-Monthly Rolling Program in all respects.

10.2.7.3 The Three-Weekly Rolling Program need not be computer-generated and does not require a detailed program analysis report. Any activity exceeding one week in duration shall be divided into sub-activities, the duration of which shall not exceed one week.

10.2.8 Other Programs

10.2.8.1 The Contractor shall provide any other programs or sub-programs of a particular portion of the Works as instructed by the Engineer.

10.3 Monthly Progress Report

10.3.1 General

10.3.1.1 The Contractor shall prepare and submit to the Engineer, six (6) hard copies and one (1) soft copy of the Monthly Progress Report (MPR) detailing the progress and current status of the Works.

10.3.1.2 The MPR shall be submitted by the 7th day of each calendar month and shall account for all work actually performed from the first day of the preceding month up to and including the last day of that month. It shall be submitted in a format agreed with the Engineer and shall contain sections and sub-sections for, but not be limited to, the topics listed below.

10.3.2 Executive Summary

10.3.2.1 The Contractor shall provide an Executive Summary covering the major achievements made during the reporting period, the activities planned for the next month and any issues that are affecting or may affect future works progress. These items are to be dealt with fully in the body of the report.

10.3.3 Financial Status

10.3.3.1 The financial status of the Contract shall include:

- a. a narrative review of all significant financial matters and actions proposed or taken in respect to any outstanding matters;
- b. a spreadsheet summarizing the contract value, value of work during the period, value of work to date, remaining work value, cash flow forecast and variance (difference between cost forecast and contract value);
- c. a spreadsheet indicating the status of all payments due and made;
- d. a graphical presentation of cost forecast (S-Curve) and actual cost to date;
- e. a report on the status of any outstanding claims. The report shall in particular provide interim updated accounts of continuing claims; and
- f. a report on the status of the Contractor’s claims and potential claims and variations.

10.3.4 Manufacturing Status

10.3.4.1 For the manufacture of each main item of plant/equipment or component thereof, the name of the manufacturer, manufacturer’s location, percentage progress, and the actual or expected dates of:

- a. Commencement of manufacture;
- b. Contractor’s inspection;
- c. Tests and Commissioning; and
- d. Shipment and arrival at the Site.

10.3.5 Contractor’s Personnel and Equipment and Employer’s Equipment

10.3.5.1 A detailed description and record of Contractor’s Personnel and Equipment and the Engineer’s and Employer’s equipment shall be provided by the Contractor, such as vehicles (if any).

10.3.6 Physical Progress

10.3.6.1 Detail description of work performed, significant accomplishments, including critical items and problem areas, corrective actions taken or planned and other pertinent activities, and in particular, shall address interface issues, problems and resolutions.

10.3.6.2 It shall include a simplified representation of progress measured in percentage terms compared with percentage planned as derived from the current detailed works program and the baseline program.

10.3.7 Program Update

10.3.7.1 The detailed works program shall be updated by recording actual activity completion dates and percentage of activities completed up to the end of the previous month together with estimates of remaining duration and expected activity completion based on current progress. The program update shall be accompanied by an activity report and a narrative statement. The narrative statement shall explain the basis of the Contractor’s submittal:

- a. Early work and baseline submittals - explaining determination of activity duration and describes the Contractor’s approach for meeting required dates as specified in

the Contract;

- b. Updated program submittals - stating in narrative the works actually completed and reflected along critical path in terms of days ahead or behind allowable dates;
- c. Actual or potential delay to the Key Dates and/or the Contract Completion Date - identifying causes of delays and providing explanation of the Works affected and proposed corrective action to meet Key Dates or mitigate potential delays. Identify deviation from previous month’s critical path;
- d. Identify by activity number and description, activities in progress and activities scheduled to be completed; and
- e. Discuss variation order work items, if any.

10.3.8 Program Status

10.3.8.1 The Program Status shall:

- a. Show the detailed works program status up to and including the current report period, display cumulative progress to date and a forecast of remaining work; and
- b. Be presented as a bar-chart size A3 and as a time-related logic network diagram on an A1 media, including activity listings.

10.3.9 Activity Variance Analysis

10.3.9.1 The activity variance analysis shall analyze activities planned to start prior to or during the report period but not started at the end of the report period as well as activities started and/or completed in advance of what is indicated in the detailed works program.

10.3.10 Procurement Report

10.3.10.1 A summary of all significant procurement activities undertaken by the Contractor during the month, including actions taken to overcome problems shall be given.

10.3.10.2 A report listing major items of plant, equipment and materials that shall be incorporated into the Works shall be provided. The items shall be segregated by type as listed in the Specifications and the report shall show as a minimum the following activities:

- a. Purchase order date - scheduled/actual;
- b. Manufacturer/supplier and origin;
- c. Letter of credit issued date;
- d. Manufacturer/supplier ship date - scheduled/actual;
- e. method of shipment; and
- f. arrival date in Philippines - scheduled/actual.

10.3.11 Production and Testing

10.3.11.1 A review of all production and manufacturing activities during the month shall be supplied to the Engineer.

10.3.11.2 Summaries of all production and manufacturing outputs during the month together with forecasts for the next month shall be given.

10.3.11.3 Review of all testing activities (either at Site or at the manufacturer's premises) during

the month.

10.3.12 Defects Notification Management Plan

10.3.12.1 The Contractor shall submit for review by the Engineer three months before the delivery of the first train a Defects Notification Management Plan as part of the Monthly Progress Report, to describe DNP activities such as repair, replace and perform any remedial item upon the Works identified by the Engineer. The Contractor shall:

- a. Complete all necessary work in a timely responsible manner;
- b. Not proceed with any remedial work without the Engineers review;
- c. Detail the methods and timing of any proposed work; and
- d. Update the plan monthly within the Monthly Progress Report, showing progress of the work and the time to completion.

10.3.13 Other Matters

10.3.13.1 The Contractor shall also include the following items within the MPR:

- a. Key Dates and progress status - A report on the status of all work item is due to have been achieved during the month and forecasts of achievement of any missed Key Dates, and those due in the next month;
- b. Three-Monthly Rolling Program - The monthly issue of the three (3) month rolling program;
- c. Interfacing and coordination - A summary of all interfacing and coordination activities during the month with external interfacing parties and interface contractors and details of outstanding actions;
- d. Safety - a review of all safety aspects during the month including reports on all accidents, actions proposed to prevent further occurrence, and safety statistics;
- e. Environmental -a review of all the environmental issues during the past month to include all monitoring reports, mitigation measures undertaken, and activities to control environmental impacts;
- f. Quality Assurance - a review of all quality assurance issues during the past month including all audits undertaken (internal and external) with a schedule detailing the status of outstanding actions;
- g. Public relations issues including complaints received, public notices, consultation meetings, etc.;
- h. Weather and other conditions, including daily temperature range, humidity, rainfall, wind speed and direction, river levels etc.;
- i. Labor returns - summary of staff and labor employed on the Site;
- j. Equipment - schedule of the Contractor’s equipment on Site with dates of arrival and departure as appropriate;
- k. Material transportation status as per the material transportation plan given Notice of No Objection;
- l. Record of documentation submitted within the month including a schedule of all submissions and consents/approvals obtained/outstanding; and
- m. Monthly photographs and video productions.

10.4 Meeting Requirements

10.4.1 Progress Meetings

- 10.4.1.1 The Engineer shall conduct progress meetings with the Contractor throughout the Contract period to enable an orderly review of the progress of the Works to be undertaken, and to provide for systematic discussion of problems and key issues. The Employer may or may not attend the progress meetings.
- 10.4.1.2 The frequency of the meetings shall be as determined by the Engineer, however, shall not be less than monthly.
- 10.4.1.3 The Contractor shall attend the meetings including the Contractor’s representative QC Manager and Safety Manager and other key personnel as appropriate. Additionally, the Contractor shall ensure that its sub-contractors, suppliers and consultants attend meetings when so required.
- 10.4.1.4 The meetings shall follow an agenda to be issued forty-eight (48) hours prior to the meeting. The agenda may vary from time to time but shall in general be focused on progress made, measurement against Key Dates and Schedule of Prices, problems encountered and solutions to such problems.
- 10.4.1.5 Persons designated by the Contractor to attend and participate in the progress meetings shall have all required experience and authority to commit the Contractor to solutions agreed upon in the meetings.
- 10.4.1.6 The Contractor shall advise the Engineer at least twenty-four (24) hours in advance of progress meetings regarding items to be added to the agenda.
- 10.4.1.7 The Engineer shall compile minutes of each meeting and shall furnish to the Contractor for review and acceptance prior to issuance by the Engineer.
- 10.4.1.8 The agreed minutes of meeting shall be considered as formal correspondence and shall be binding on all parties. The meetings shall be held in a venue or by audio / video conference determined by the Engineer; however, to the maximum extent practicable, meetings shall be held at the Engineer's office.

10.4.2 Operation Meetings

- 10.4.2.1 Besides the progress meetings above, the Employer and the Engineer shall also conduct operational meetings with the Contractor and PNR as required. These meetings shall cover train operation issues related with the construction Works, including train operation, Works in the vicinity of the PNR railway, window time and material transport, etc.

10.4.3 Progress Reporting

- 10.4.3.1 The Contractor shall submit fortnightly a progress dashboard. This dashboard shall be accompanied by a detailed Material Control Schedule which tracks and records all material procurement activities. The formats used are to be agreed and given Notice of No Objection by the Engineer..

11 Parts List, Special Tools and Test Equipment

11.1 Details of Supply

- 11.1.1 Not later than two months before manufacture of a system/sub-system, the Contractor shall submit to the Engineer a parts list for delivery, including parts numbers, description/name and quantities for all delivery to be done.

11.1.2 The Contractor shall submit for review for the systems/sub-system one copy of a complete list of spare parts, special tools, jigs, fixtures and gauges, supplementing, adding or elaborating the list submitted with his Bid and finalized during the award, for the supply of spares during the Defects Notification Period. All additions shall be at no extra cost to the Employer.

11.2 Manufacture and Delivery

11.2.1 Spares shall be manufactured, works tested and delivered to the Employer by the Contractor, at such times as required by the Engineer, suitably packed and identified for prolonged storage.

11.2.2 They shall be considered and delivered in accordance with the Engineer’s instructions. The Engineer reserves the right to order spares to be inspected or tested on receipt and re-packed if given Notice of No Objection. The information supplied in respect of each spare part or special tool shall include, but not be limited to, the following:

- a. The manufacturer's part number;
- b. Space for the Employer's part number;
- c. Description - a full description of the spare part, including a note as to whether it is a sealed unit or whether it is an assembly or sub-assembly which can be broken down into component parts. The detail of the breakdown shall be included as part of the submission under Sub-Clause 13.4;
- d. Quantity supplied;
- e. Expected utilization in twelve months;
- f. Overall dimensions and weight including packing (if any) for shelf space purposes;
- g. A note as to interchangeability or otherwise with similar parts;
- h. The unit price;
- i. The source - the manufacturer's name and address; and
- j. The normal manufacturing and shipment lead times for additional quantities.

11.2.3 The presentation of the above information shall be reviewed by the Engineer on behalf of the Employer.

11.3 Special Tools and Test Equipment

11.3.1 One set of special tools, test equipment, jigs, fixtures and gauges required to carry out all functions described in the maintenance instructions or as required by the Particular Technical Requirements shall be delivered before the issue of Taking Over Certificate, which shall not be less than the list of equipment provided by the Contractor, along with his bid. The Contractor may add any additional equipment required, but, at no extra cost to the Employer. The extent of supply shall include protective or carrying cases, as may be appropriate for the storage and use of each item.

11.4 Capital Spares

11.4.1 The Contractor shall provide sufficient number of capital spares which shall not be less than the list of equipment provided with the Bid and finalized during the award, to ensure that the operation of the MCRP and NSRP-South Line shall not be interrupted for longer than it takes to install the capital spare or to ensure that the operation of the system is not degraded longer than the time it takes to expedite the spare. The Contractor

may provide additional capital spares, but at no extra cost to the Employer.

11.5 Consumable Spares

- 11.5.1 The Contractor shall provide all spare parts for all of its supplied equipment necessary during the Defects Notification Period, the price of which shall have been included in the Schedule of Prices.
- 11.5.2 The spare parts shall be listed in a practical format.
- 11.5.3 The stock of all consumable spare parts shall be replenished at the end of the Defects Notification Period to match as a minimum the list of consumables of the bid and be handed over to the Employer.

11.6 Start-Up Material

- 11.6.1 The Contractor shall provide all material for testing and commissioning and sufficient material to start the service.

11.7 Spare Parts Installation Support

- 11.7.1 The Contractor shall provide sufficient maintenance support staff to ensure that the all spares can be efficiently installed during the Defects Notification Period.

11.8 (Not Used)

11.9 Train Operation Simulator Parts

- 11.9.1 The Contractor shall transport, set up and adjust the train operation simulator parts by the designated date.

12 Inspection, Testing and Commissioning

12.1 General

- 12.1.1 The Contractor shall perform all necessary testing and commissioning activities in order to ensure satisfactory operation of the Rolling Stock completed system plus compliance with the requirements of the Technical Requirements. The Engineer shall witness the tests as set out in the test plan.
- 12.1.2 The test of the signaling Equipment provided by the CP NS-01 Contractor shall be part of the test plan and the technical responsibility for integrated performance sets with the CP NS-01 Contractors.
- 12.1.3 All inspections, testing and commissioning shall be clearly identified in the Quality Management Plan identifying the witness, inspection and hold points as required by the Contractor, the Engineer or both. The quality management plan shall be submitted by the Contractor to the Engineer for review in accordance with the Quality Management Plan (refer Sub-Clause 7.1).
- 12.1.4 All tests shall be carried out by the Contractor in the presence of the Employer and the Engineer in accordance with the agreed Quality Management Plan.
- 12.1.5 The Contractor shall provide testing procedures that shall be in accordance with the Technical Requirements and the International and Philippine Standards (as specified in the Technical Requirement Sub-Clause 1.2.2, Codes, Standards and Requirements).

- 12.1.6 The Contractor shall appoint a dedicated test and commissioning manager, to coordinate all activities of the commissioning schedule.
- 12.1.7 All costs associated with testing shall be borne by the Contractor, including any expenses incurred due to re-testing caused by defects or failure of equipment to meet the requirements of the Contract in the first instance.
- 12.1.8 The cost of permanent power which is consumed in testing and commissioning by the Contractor as part of the Works shall not be the responsibility of the Contractor.
- 12.1.9 The cost to provide water and other services including train operation personnel (train operators and rolling stock personnel) required for inspection, testing and commissioning including integrated testing and commissioning and trial run shall be borne by the Contractor. Train operator and associated rolling stock personnel required for all Interfacing Contractors will be provided by the CP NS-02 Contractor (24/7) as required) for the completion of testing & commissioning.

12.2 Inspection, Testing and Commissioning Plan

- 12.2.1 According to Sub-Clause 20.2.2 of the ERT the Contractor shall submit to the Engineer for review an inspection, testing and commissioning plan giving full details of all tests to be carried out under the Contract with an explanation of the planned achievements.
- 12.2.2 The plan shall demonstrate that the Rolling Stock conforms to specifications, standards and other normative documents.
- 12.2.3 Testing and commissioning shall be in accordance with the Railway Application Standard JIS E4041 for testing of Rolling Stock or on completion of construction and before entry into service and according to Clause 20 of the ERT.
- 12.2.4 The inspection, testing and commissioning plan shall include as a minimum the following tests:
 - a. Design Qualification Testing: As part of the design verification process, type tests shall be carried out to demonstrate that the design of the Rolling Stock and its systems are in full compliance with the requirements;
 - b. First Article Inspection: The first component produced shall be subjected to a rigorous test and inspection to confirm that the hardware fully complies with the Contractor’s design and manufacturing process requirements;
 - c. Factory Acceptance Tests: Tests to be performed at the factory, before equipment is shipped as it is set out in the Sub-Clause 20.4.2 of the ERT;
 - d. On-Site Testing and Commissioning: Tests to be performed after delivery of the Rolling Stock at the Site comprising static and dynamic tests. After static tests at the depot, dynamic tests shall be carried out on the main line; and
 - e. Trial Operations: The Contractor shall undertake Trial Operations which shall take place at the completion of the testing and commissioning process. The Trial Operations shall be supported by the Engineer and other interested parties. It consists of operating the newly procured Rolling Stock, consideration simulating requirements of operating the trains for revenue service, but without active passengers.

12.3 Test Procedures

- 12.3.1 The Contractor shall supply his proposed Test Procedures for review by the Engineer 3 months prior to the scheduled commencement of the testing (refer to Sub-Clause 20.6.1 of the ERT).

12.4 Conditions Prerequisite to Inspection by Engineer

- 12.4.1 Written notice submitted by the Contractor requesting Inspection shall mean that the work is ready and the Contractor have themselves:
- a. Inspected and checked all work completed;
 - b. Compared all work with the drawings, specifications, and submittals as given Notice of No Objection;
 - c. Confirmed that all conditions, provisions and requirements of the Contract documents have been fulfilled, other than any maintenance and incidental work and procedures necessary to follow; and
 - d. Systems, equipment and devices are properly adjusted, serviced, tested and fully operable.

12.5 Test Instruments

- 12.5.1 All test instruments used during the testing and commissioning phases shall be calibrated in accordance with industry standards. Calibration test certificates shall be supplied in duplicate at the Contractor's expense and shall be signed and dated clearly identifying the type of test equipment, serial number, date of calibration test and expiry date of the calibration period. All calibration checks shall be undertaken prior to testing and, if required by the Engineer, shall be repeated afterwards.
- 12.5.2 All test instrumentation shall carry a self-adhesive calibration identification label which clearly identifies the serial number of the equipment, the date when calibrated and the expiry date of the calibration.

12.6 Test Reports

- 12.6.1 After completion of each test, whether witnessed by the Engineer or not, the Contractor shall no later than fifteen (15) additional elapsed days prepare and forward the Test Report to the Engineer for review (refer to Sub-Clause 20.6.2 of the ERT). A punch list shall be created that identifies any deficiencies and or deviations from the detailed design given Notice of No Objection and shall be attached to the test results.

12.7 Commissioning Coordination

- 12.7.1 The Contractor shall appoint a test and commissioning manager who shall work very closely with the Engineer to coordinate all activities of the commissioning schedule.
- 12.7.2 The Contractor shall ensure that they have produced the testing & commissioning procedures and reports for the Rolling Stock and as far as is practicable, they have advanced the Rolling Stock testing. In the areas where the CP NS-01 Contractor has scope of work, e.g. driver’s cab, signaling, installation, then the CP NS-01 Contractor shall take the lead for the integrated testing & commissioning in areas like this for CP NS-02 and other CP NS-01 Contractors, e.g. the on-board signaling equipment shall be provided by the CP NS-01 Contractor, as is described in Clause 16 of the ERT.
- 12.7.3 The on-board signaling equipment shall be provided by the CP NS-01 Contractor as it is described in Section 16 of the Technical Requirements.

13 Operation and Maintenance Manuals and Drawings

13.1 General

13.1.1 No later than two months prior to commissioning, the Contractor shall submit to the Employer and the Engineer for review, six (6) preliminary copies of operating instructions, maintenance instructions, maintenance drawings and illustrated parts catalogs (IPC) for the Rolling Stock in accordance with the requirements stated herein and Section 19 of this ERT.

13.2 Operating and Maintenance Instructions

13.2.1 The Operating & Maintenance instructions shall be in sufficient detail to enable the Employer to operate, maintain and repair each part of the electrical and mechanical system. This shall include but not be limited to the following:

- 1) A description of all the equipment and its component parts;
- 2) Original Equipment Manufacturer’s brochures shall be in English language;
- 3) The characteristics, ratings and any necessary operating limits for all the equipment;
- 4) Recommended interval of inspection/replacement;
- 5) Inspection/measuring point/item and criteria;
- 6) Instructions for lubrication and recommended lubricant;
- 7) Instruction of removing and re-installing consumable parts;
- 8) Instruction on dismantling and re-assembly at overhaul; and
- 9) Testing and re-commissioning procedures after re-assembly, overhaul or replacement of equipment.

13.2.2 The version given Notice of No Objection of all manuals shall be provided in electronic format, indicating revision and which shall not allow changes and six hard copies, properly bound and oil and dirt resistant.

13.3 As-Built Drawings

13.3.1 Drawings showing the Works as-built, shall be prepared by the Contractor and submitted for approval. The Contractor shall submit to the Employer six (6) prints of each drawing and six (6) copies of the electronic files. The electronic format shall be given Notice of No Objection by the Employer.

13.4 Maintenance Drawings

13.4.1 The Contractor shall provide maintenance drawings as it is required for the maintenance of the Rolling Stock by the Employer. Drawings shall be provided as detailed by Section 19 the ERT.

13.4.2 Information contained on the drawings shall include but not be limited to:

- a. Setting dimensions, parameters and tolerances, specifications, ratings, etc.;
- b. Sizes and materials of all fixtures and threads;
- c. Weights of assemblies;
- d. Wiring diagrams to appropriate standards, including internal wiring of sealed unit items; and
- e. Type and manufacturer’s codes of parts/sub-assemblies.

- 13.4.3 The version given Notice of No Objection of all drawings shall also be provided in electronic format which shall not allow changes. Six (6) properly bound with oil and dirt resistant hard copies shall be provided.

13.5 Illustrated Parts Catalogs

- 13.5.1 The Contractor shall submit six (6) copies of complete illustrated parts catalogs (IPC) and overall "exploded views" of assemblies and sub-assemblies for Rolling Stock which shall include also reference to all assemblies, sub-assembly special tools, jigs, fixtures and gauges required for the operation and maintenance of the Rolling Stock. All sub-assemblies shall have separate detailed specification and part numbers for ordering/re-ordering requirements.
- 13.5.2 The IPC shall be provided in electronic format, the format shall be given Notice of No Objection by the Engineer and for hard copies properly bound and oil and dirt resistant.

13.6 Modifications, Configuration Tracking

- 13.6.1 The Contractor shall provide a vehicle history book for each vehicle at the time of acceptance. Each vehicle history book shall contain the vehicle specific information as well as the history of all maintenance and modifications as it is set out in the ERT (refer to Sub-Clause 19.9).
- 13.6.2 It may prove the case that the Contractor shall need to amend his submissions during commissioning of the Rolling Stock and/or during the Defects Notification Period.
- 13.6.3 In this case it is the Contractor’s responsibility to document and to show the change of the configuration. This shall be amended to the History Book. This shall also include the tracking of the software release in case of updating software, operating and maintenance instructions, maintenance drawings, As-built drawings and IPC, etc.

14 Training

14.1 Training Requirement

- 14.1.1 The Contractor shall be required to train or arrange training for Employer’s Personnel in accordance with the requirements of the Railway Operator’s program. These staff shall include the Railway Operator’s key instructors who shall require training in technical matters in order to conduct future training courses.
- 14.1.2 The Contractor shall assume on the part of the Employer’s personnel that they are starting on the premise of zero (0) knowledge of the equipment, etc. and the training must be designed to upgrade the delegate’s knowledge to that where they are proficient.
- 14.1.3 Training shall include provision of all required training materials, appropriate training venues, competent instructors, plant, equipment and all necessary aids to support training courses.
- 14.1.4 The Contractor shall recognize the dates for Trial Operations and shall ensure that all appropriate personnel have received adequate training to equip them for all of the tasks required during Trial Operations before the commencement of the Trial Operations.
- 14.1.5 Additional training may be required during Trial Operations as may be identified by the Employer /Engineer.

14.2 Training Objectives

- 14.2.2 The Contractor shall provide comprehensive training to the Employer’s personnel to

enable all of the systems and equipment supplied, installed or modified to be operated and maintained in the designated manner safely and efficiently so as to achieve the maximum reliability and economy.

- 14.2.3 Training objectives in terms of minimum standards to be achieved by each trainee role shall be clearly defined by the Contractor.

14.3 Types of Training

- 14.3.1 The Contractor shall be required to provide training for:

- a. Operations staff who are required to operate the equipment or system under normal, degraded and emergency situations and recover from minor faults;
- b. Maintenance staff who will undertake recovery or corrective maintenance, routine or preventive maintenance and specialize in repair and overhaul of Rolling Stock equipment;
- c. Engineering Design Staff who are technical support staff specializing in system administration, fault analysis and investigation techniques associated with the particular type of equipment and system; and
- d. Key instructors who shall be required to develop the skills necessary to conduct future training courses.

- 14.3.2 The Contractor shall provide additional training and training materials where appropriate to impart the skills and knowledge required for the maintenance and/or operation of any part of the Works which is subjected to modification under the Contract.

14.4 Training Plan

- 14.4.1 The Contractor shall submit a Training Plan to the Employer and the Engineer for review within twelve (12) months from the Commencement Date.

- 14.4.2 The Training Plan shall provide a structured training program to educate and train the Employer’s personnel in all aspects of the system operation and maintenance and shall include, but not be limited to, the following:

- a. Approach to structuring and providing the courses required;
- b. Schedule of training courses;
- c. Title, objective, syllabus, method, location, number of classes, class size, course contents and estimated duration of each training course;
- d. List of training materials, documentation and equipment to be included with the training courses;
- e. Testing and assessment to be utilized;
- f. Qualifications and experience level necessary for the trainees;
- g. Qualifications of Contractor’s instructors; and
- h. Course evaluation methods.

- 14.4.3 The Contractor shall use a modular approach in developing the training curriculum in order to facilitate the O&M trainers to adopt the courses for different level of staff who may have different needs in terms of depth of knowledge and skills of a specific system.

14.5 Training Method

- 14.5.1 The training shall be planned and carried out in a manner suitable for the intended role, and shall at a minimum consist of the following:
 - a. Classroom (theory) training; and
 - b. Practical (hands on) training.
- 14.5.2 Other training methods, for example, computer based interactive computer-based training (CBT), simulator training, on-the-job training shall be adopted where applicable.
- 14.5.3 All training courses shall be conducted in English.

14.6 Training Location

- 14.6.1 The training shall be carried out at such locations where the greatest benefit for trainees may be gained. This may be in the Philippines, at places of manufacture, assembly or testing, or at such other locations as may be necessary. All places of training shall be subject to the approval of the Employer.
- 14.6.2 The Contractor shall be responsible for the reception of employees, plus hotel and travel arrangements and costs for each trainee in regions other than Manila.

14.7 Contractor’s Training Staff

- 14.7.1 The Contractor shall provide competent instructors to carry out training to a high degree of proficiency in areas where the Contractor has the specialized knowledge. All instructors shall have a good command of English language and training skills. Should, in the opinion of the Engineer, any of the Contractor’s instructors not be considered to be competent or do not have a suitable aptitude for carrying out training courses for whatever reason, the Contractor shall remove the said person and replace him or her as soon as possible with a competent substitute.
- 14.7.2 The Contractor shall assign a training coordinator from his organization to be responsible for training. The training coordinator shall be the main contact for all matters related to training.
- 14.7.3 The Contractor shall provide full time on-site management and coordination of the training to ensure continuity of classes and proper distribution of training materials and to be responsible for interfacing with the Contractor’s instructors.
- 14.7.4 Where the trainees are attached to the Contractor or his subcontractors for the purpose of gaining job experience, all such trainees shall be properly supervised and monitored by a qualified training supervisor to ensure that each trainee has the best opportunity to benefit from the practical experience.

14.8 Pre-requisite of Trainees

- 14.8.1 The Contractor shall submit measurable criteria for selection of trainees, indicating minimum standards desired in each course, in terms of:
 - a. qualification and/or educational standards required;
 - b. skills and knowledge levels desired, or any special aptitude necessary; and
 - c. oral and written ability.

14.9 Training Materials, Plant and Equipment

- 14.9.1 The Contractor shall provide, at their own cost, such written or printed matter, samples, models, cut-away equipment, devices, slides, films and other instructional material, as may be necessary for training. Such materials shall be retained by the Employer at the end of the training.
- 14.9.2 Manuals to be used during training shall be developed based on the O&M Manuals and delivered to the Engineer at least eight (8) weeks prior to the commencement of the first training session of the course for review and comment. The manuals shall be accurate, complete and of professional quality.
- 14.9.3 The Contractor shall provide a full set of training manuals, including an individual training plan, an instructor guide and a trainee manual for each training course. The instructor guide shall include the course agenda, objectives, list of resources and facilities required, detailed lesson plans, presentation notes, discussion guides, training aids, test papers, criteria and methodology for testing and assessment, and all other things that shall enable the railway operator’s key instructors to roll out the training.
- 14.9.4 All training manuals shall be written in English and in a specified standard format.
- 14.9.5 All training manuals are to be submitted to the Engineer for the review initially with further copies dispatched during the training delivery including a soft copy that allows easy reproduction.
- 14.9.6 In general, the Contractor shall use plant and materials specifically set aside for training purposes. However, the Contractor may use, subject to the agreement of the Engineer, installed plant and equipment when no other such plant and materials are otherwise available. The Contractor may use spare parts or assemblies that form the Contractor’s spares for this purpose, provided that the Contractor shall replace any component or parts which incurred damaged due to mishandling and improper procedure during the training at no cost to the Employer.
- 14.9.7 The supply of training materials and equipment shall be sufficient both for the trainees trained by the Contractor and for those to be subsequently trained in the rollout training.

14.10 Testing and Assessment

- 14.10.1 The Contractor shall conduct periodical theoretical and practical tests for all trainees to assess the level of knowledge and understanding of the course content.
- 14.10.2 The Contractor shall, at the completion of each training course, issue an appropriate certificate to each trainee who has successfully completed the course.

14.11 Monitoring & Course Evaluation

- 14.11.1 The Engineer and railway operator’s relevant department shall have free access to all training sessions to monitor the progress of the trainees and the Contractor’s instructors.
- 14.11.2 The Contractor shall, at the conclusion of each training course, issue questionnaires to all trainees directed at determining the level of satisfaction with the course content.
- 14.11.3 The Contractor shall review the responses to questionnaires and forward a summary to the Engineer. If the Engineer considers that the course has not achieved the required objectives, the Engineer shall advise the Contractor who shall then organize and implement appropriate re-training at no additional cost.

14.12 Records

- 14.12.1 The Contractor shall permit the Employer and railway operator to record video images

of any of the training and to have the right to use these recordings at any time.

- 14.12.2 The Contractor shall, at the completion of each training course, provide the Engineer with a consolidated training record listing the course title, date of training, name of all trainees, training result and relevant information.
- 14.12.3 Training records shall be kept up-to-date and made available to the Employer or to his representative for examination when required to do so.

14.13 Administration

14.13.1 The Contractor shall:

- a. be responsible for the safety, health and general welfare of trainees under his control; and
- b. submit for the Employer’s approval, procedures which shall enable them to control, and to repatriate where necessary those trainees not found to be responding to training as a result of aptitude, discipline and any other cause.

15 Equipment Identification

- 15.1 All labels on any piece of equipment, cable, pipe, etc. shall be identified as shown on the drawings given Notice of No Object and or circuit diagrams.
- 15.2 All equipment and materials supplied shall be indelibly labeled or otherwise identified to show its identity, type, version, function, location, rating or limitation as appropriate. Removable modules such as relays, breakers, etc. shall have the same indelible labeling on the fixture to which the module is attached. The label shall be adjacent to or on the module and shall not be obscured.
- 15.3 All warnings, instructions or identification labels shall conform to current directives and a unified system of labelling for all services shall be used subject to the approval of the Engineer.
- 15.4 All wires shall be labelled at connection of terminal or connectors with identifying numbers indicated in wiring diagrams and terminal numbers or pin numbers of connectors.
- 15.5 All labels used shall be highly durable, scratch and chemical resistant and have high UV resistance.

16 Publicity and Public Relations

16.1 General

- 16.1.1 The Contractor shall prepare and submit a Public Relations (PR) plan as part of the Project Management Plan to the Engineer. The Contractor shall also carry out PR activities and public consultation works with the instruction and guidance of the Engineer. The responsibilities of the Contractor shall, without limitation, include:
 - a. Coordinate public relations matters and exercises with the Engineer and keep the Engineer informed at all times of relevant issues;
 - b. Engage and liaise with relevant local government departments, other authorities and key stakeholders to develop and coordinate public relations exercises;
 - c. Establish a sense of partnership among the government and stakeholder groups in the implementation of the Project;
 - d. Promote the Project to the public and the parties concerned with a positive message

- and explain the benefits which shall be realized by the development of the Project;
- e. Gain support and minimize objections from the community and concerned parties;
- f. Ensure adequate transparency of the Project to the public and key stakeholders;
- g. Implement a robust process for receiving, addressing and tracking comments, criticism and complaints from all parties during the Contract;
- h. Resolve public relations issues arising during the course of construction and elevate major issues to the Employer via the Engineer, as required;
- i. Prevent and/or mitigate any nuisance or disturbance to the public due to the construction activities at the earliest possible time;
- j. Attend and answer queries for the purpose of public consultation including but not limited to LGUs, MMDA, PNR, Emergency Services, Stakeholders, the Employer, related competent agencies, Non-Governmental Organizations (NGOs) or individual members of the public, local authorities and people in the affected areas, during and outside normal office hours;
- k. Prepare and supply all necessary drawings, photomontages, documents, consultation papers, presentations, display materials, etc. for public consultations; and
- l. Provide assistance and information to facilitate all Public Relations (PR) activities as per the PR Plan and as instructed by the Employer and the Engineer.

16.1.2 The Contractor shall nominate a qualified and experienced Public Relations Manager to manage and coordinate the required public relations responsibilities.

16.2 Public Relations Plan

16.2.2 The PR Plan shall include the methodology, specific ways and actions to be carried out for informing and consulting the public and promotion of the Project. The PR Plan shall also include the methodology specific ways and actions to handle reactions from the public, in particular issues relating to congestion, pollution, vibration, ground movement, noise, nuisance, compensation, etc.

16.2.3 The PR Plan shall give proposals and details on effective liaising, consulting, informing, meeting, contacting, clarifying with the public and gaining their support and understanding on the importance and benefits of the MCRP and NSRP-South Project and the mitigation measures to reduce the impacts which may generate during execution of the Works.

16.2.4 The Contractor shall update quarterly and submit the PR Plan including a summary of PR events conducted and complaints, queries handled in the past quarter and PR events to be conducted and complaints and queries envisaged in the future, throughout the Contract period.

16.3 Public Consultation

16.3.1 The Contractor shall undertake public consultation works with the guidance of the Engineer, including but not limited to, the following:

- a. Inform and consult the relevant Government departments and authorities concerning the Project, local residents, property developments, shops, schools and sensitive receivers at least two months prior to the commencement of construction works;
- b. Attend and participate in all public consultations and PR exercises;

- c. Gain support, ease concerns and minimize objections from the public affected by the construction works through public consultation;
 - d. Address public concerns and feedback as far as possible to minimize disturbance to the public during construction, at the Contractor’s own expenses; and
 - e. Report and give presentations to the Engineer, Employer, stakeholder agencies, NGOs and local authorities of the affected areas, about the progress of the construction works and other information as requested.
- 16.3.2 The Contractor shall ensure proper communications with the public by establishing an effective communication channel. The communications shall be open and transparent in the form of an interactive two-way system. Stakeholders and parties concerned shall be updated regularly on the progress of the Works and implementation of the Project through an easily accessible system, in particular on matters relating to local traffic control arrangements, expected delays, etc. Queries, feedback and comments from the stakeholders and parties concerned shall be considered and handled properly in an effective manner. An effective communication system of on-site notices, website and phone hotlines shall be established by the Contractor.

16.4 Public Relations Tools

- 16.4.1 The Contractor shall provide and make use of, but not be limited to, the following Public Relations tools in carrying out its PR duties.

16.4.2 Newsletter

- 16.4.2.1 The Contractor shall design and produce newsletters with the guidance of the Engineer at three-monthly intervals throughout the construction period and distribute to concerned Government departments, the Employer, stakeholders, related competent agencies, NGOs or individual members of the public, local authorities and people in the affected areas, etc. The newsletters shall be published in both English and Filipino Language providing in depth descriptions of the MCRP and NSRP-South Project and the latest development and construction progress of the Works. It shall highlight the benefits of the Project, Schedule of Prices events of the construction activities and mitigation measures taken to minimize the impact to the public. Ways of communication channels shall also be published in the newsletters such as the website, and phone numbers of the enquiry hotline.

16.4.3 Website

- 16.4.3.1 The Contractor shall establish a website with the guidance of Engineer and Employer which gives a clear description of the MCRP and NSRP-South Project, the Works, indication of anticipated completion date, public relations exercises, traffic control issues and details of the enquiry hotline. The website shall be updated regularly to ensure that the information is up to date. The site shall make provision for the public and stakeholders to submit comments, feedback and complaints, which shall be addressed and responded to by the Contractor as per the PR Plan.

16.4.4 On-Site Notice

- 16.4.4.1 The Contractor shall post on-site notices with the guidance of the Engineer with a clear description of the Works and indication of anticipated completion dates together with the enquiry hotline and internet website information. Advance notices shall be given in carrying out the Works which maximize the impact on local residents.

16.4.5 Hotline

- 16.4.5.1 The Contractor shall set up a twenty-four (24) hour hotline with the guidance of the Engineer to provide enquiry services to the public and the Contractor shall ensure queries and enquiries regarding the Works are taken seriously and dealt with swiftly.
- 16.4.5.2 Whenever a complaint is received, response shall be made within seven (7) calendar days. If a longer processing time is needed, an interim reply shall be served to the complainant within seven (7) calendar days.

16.4.6 Construction Site Tour

- 16.4.6.1 The Contractor shall cooperate with and provide periodic tours of the Works to the public and stakeholders during the construction period. The main target audiences are stakeholders, ordinary families and students. Site visitors can become a means for advertising and promoting the benefit of the MCRP and NSRP-South Project. Tours shall be planned at least once in every three months, subject to the Engineer’s review.

16.4.7 Coordination with Other Contractors

- 16.4.7.1 The Contractor shall coordinate with external interfacing parties and interface contractors in the implementation of public relations activities.

16.4.8 Measurement and Payment

- 16.4.8.1 No separate payment shall be paid for preparing and submitting the public relations plan, public consultation, and public relation tools all associated costs shall be deemed to be included in the other BOQ items describe above.

17 (Not Used)

18 Requirement Management

- 18.1 The Contractor shall use requirement relational data base software similar or equivalent to the Engineer and Employer software. All the cost associated to the software usage and maintenance shall be under contractor own cost.
- 18.2 The Contractor shall appoint a suitably qualified and competent person to carry out requirements management.
- 18.3 The Requirements Management Database shall be populated with V&V evidence. The V&V process aim to reduce risk and evolve a fully integrated system in order to provide confidence in the ‘as designed’ and the ‘as built’ solutions.
- 18.4 The Contractor shall prepare and submit to the Engineer a Requirement Management Plan within thirty (30) days of the date of the commence date. The Requirement Management Plan shall define the processes employed by the Contractor to ensure that all appropriate requirements are managed to ensure the proposed design solution meets the design requirements and demonstrated through verification and validation evidences. The Requirement traceability database will be managed through the relational database.
- 18.5 The Contractor shall develop a database of all requirements associated with a number of definition documents defined such as but not limited to, the ERG and ERT. The Contractor will then provide evidence that the identified requirements have been managed

appropriately. The database shall:

- (a) Ensure that the criteria for the purpose of verification and validation of the Requirements has been recorded with appropriate attributes assigned;
- (b) Ensure that compliance of the complete set of the Requirement can be demonstrated with evidence formally recorded;
- (c) Ensure that the Requirements are consistent and traceable back to their sources, and any gap/mismatch in the Requirements are clearly identified;
- (d) Establish formal deliverable which will support stage design reviews and the overall engineering management processes;
- (e) Track and record Requirement changes and facilitate impact analysis on Requirement changes; and
- (f) Track and record assumptions, if there are any, evaluating the stability of, and the impact on, the Project if any of the assumption prove to be true or false, defining the actions necessary to make progress and monitor the assumptions, and scheduling when assumptions are to be validated and reviewed throughout the Project’s life duration.

18.6 The Contractor shall issue a monthly status report by providing status information on issues such as the number of open and closed requirements.

19 Asset Management

- 19.1 All assets will be subject to the requirements set out in the Asset Management Plan.
- 19.2 Asset management, work planning, work history and asset performing reporting will be carried out using a Computerized Maintenance Management System (CMMS). The CMMS is a software based system that will be available to the maintenance and operation organization with equipment at the Depots and OCCs.
- 19.3 The Contractor shall provide asset data for input into CMMS.
- 19.4 Plant and Material shall be designed to meet the Requirement for the for the specified design life in ERT.
- 19.5 The design life of the system and components shall be considered during the project design stage.
- 19.6 The total life cycle cost approach shall be adopted in evaluating design alternatives. System design shall be optimized with respect to the total cost of initial acquisition, operation, maintenance, system support and disposal over the life cycle. The Contractor shall provide supporting data and technical analysis to demonstrate compliance with this requirement.
- 19.7 An adequate supply of spare parts and test equipment shall be made available for a period of time from completion of the Works in accordance with Obsolescence Management Plan. The Contractor shall notify the Employer/Operator at least six (6) months prior to deleting any component of the supplied equipment from general availability and guarantee to provide functionally replacement units for the remainder of such specified period of time.
- 19.8 All assets data are to be deposited and managed in the System Configuration Database Platform as part of the delivery of CMMS.
- 19.9 The Contractor shall provide an asset register for populating the CMMS Database server. The register shall comprise, but not limited to:
 - a. Part name;
 - b. Part number;
 - c. Functional use;
 - d. System, sub0system, equipment and component level hierarchy for populating the CMMS Database configuration;
 - e. Maintenance requirements.
 - f. Maintenance history;
 - g. Spares stock holding;
 - h. Supplier;
 - i. Contact name and address.
- 19.10 The Contractor shall provide administrative schedule information for populating the CMMS database server. The schedule shall include but not limited to:
 - a. Personnel details;
 - b. Training;
 - c. Warranties;
 - d. Work schedule;
 - e. Job cards.
- 19.11 All warranties shall be transferred to the Employer/Operator. All spares, special tools and

equipment shall be supplied to the owner/Operator.

- 19.12 The Contractor shall produce an Obsolescence Management Plan for review within ninety (90) days upon commencement of work.
- 19.13 The plan shall consider the project related risk associated with the obsolescence issue in connection with equipment/spare parts, hardware and software during the design. And though to its first estimated obsolescence phase.
- 19.14 Obsolescence shall be evaluated by the Contractor when planning the levels of spares holding.
- 19.15 The Contractor shall submit an Obsolescence Management Report for review at the conclusion of the final design. The report shall contain details of the management of the system and components throughout the life of each asset.

20 Interface Management

20.1 General

- 20.1.1 The Contractor’s responsibility for interface coordination shall include interfacing with the following interface contractors and those who may be identified in the future such as local authorities, statutory bodies, utility undertakings, private service providers, consultants or other contractors whether or not specifically mentioned in this Contract. This responsibility is not limited to a particular number of interface contractors.
- 20.1.2 The Contract Package shall be stated as follows:
 - 1) CP N-01~04: CIVIL Works
 - 2) CP N-05: DEPOT Works
 - 3) CP S-01~06: CIVIL Works
 - 4) CP S-07: DEPOT Works
 - 5) CP NS-02: Rolling Stock – Commuter Trainsets;
 - 6) CP NS-03: Rolling Stock – Limited Express Trainsets; and
 - 7) CP NS-01: E&M System and Track Works.

20.2 Exchange of Information with External Interfacing Parties and Interfacing Contractors

- 20.2.1 The Contractor shall communicate, coordinate and exchange information directly with external interfacing parties and interface contractors. Information necessary to fulfil the Contractor’s interface obligations shall be directly requested and obtained from the external interfacing parties and interface Contractors. Information receipt and acknowledgment procedures shall be implemented by the Contractor. Conversely, the Contractor shall provide information which is related to the Contractor’s scope of work, as required, directly to the relevant external interfacing parties and interface contractors.
- 20.2.2 The Contractor shall communicate and cooperate with the interface contractors to identify and resolve potential interface problems and to coordinate the works.
- 20.2.3 The Contractor shall allow for the fact that many of the design activities of the interface contractors may proceed concurrently with the Contract. Specific dates for the delivery of this and other required information shall be confirmed between the Contractor and the interface contractors.
- 20.2.4 The Contractor’s program shall allow for the timing of availability of necessary

interface information from the interfacing parties.

20.3 Request for Information

20.3.1 All Requests for Information (RFI), acknowledgement of receipt of information, and any official communications between the Contractor and the interface contractors/external interfacing parties shall be made in writing with a copy to the Engineer for information.

20.4 Interface and Coordination with Interfacing Contractors/External Interfacing Parties

20.4.1 The Contractor shall advise the Engineer in writing of any problems encountered in obtaining necessary information and/or lack of cooperation from any interface contractor/ external interfacing parties. In the event that the Engineer considers that the resolution of an interface is not proceeding satisfactorily, the Engineer shall review the matter and establish a coordinated plan directing the Contractor and the interface contractors as to the required action.

20.4.2 The Contractor is responsible for detailed coordination of their design and manufacturing activities with those of the interface contractors and consultants whether or not specifically mentioned in the Contract, who may be working for the purpose of the Project.

20.4.3 The Contractor shall note that there are other contractors, consultants, agencies etc., which the Employer may engage from time to time, and with whom the Contractor shall have to similarly coordinate. Such coordination responsibilities of the Contractor shall include the following, but not be limited to:

- a. Provide all information reasonably required by the Interface Contractors in a timely and professional manner to allow them to proceed with their design, manufacturing, construction activities, and to meet their Schedule of Prices and work program dates, if any;
- b. Ensure that the Contractor's requirements are provided to all other interface contractors, in a timely and reasonable manner;
- c. Obtain from the Interface Contractors information reasonably required, to enable the Contractor to meet their own design submission dates;
- d. Where the execution of the work of the interface contractors depends upon the Site management or information to be given by the Contractor, the Contractor shall provide to such interface contractors the services, or the correct and accurate information required, enabling them to meet their own program or construct their own works;
- e. To ensure that there is no interference with the works of the interface contractors; and
- f. To attend regular coordination meetings convened by the interface contractors and the Engineer. The Contractor shall conduct separate meetings with the interface contractors as necessary to clarify particular aspects of the designated requirements of the Works. A record of the decisions taken in each such meeting shall be furnished to the Engineer. The party who convenes the meeting shall prepare minutes recording all matters discussed and agreed at the meeting.

20.4.4 The Contractor shall establish a dedicated coordination team, led by an interface coordinator reporting to the Contractor's Project Manager. The primary function of the team is to provide a vital link between the Contractor's design and manufacturing teams

and the interface contractors. The Engineer shall have the right to require the replacement of the Coordinator if in his opinion the coordinator is unable to meet the coordination requirements of the Contract. The Contractor's attention is drawn to the need for the coordinator to establish effective dialogues and communication links with the interface contractors. The Contractor's coordination team shall comprise a mix of personnel with experience in both design and manufacture of Rolling Stock necessary for effective coordination.

- 20.4.5 The coordinator shall assess the progress of coordination with the interface contractors by establishing lines of communications and promoting regular exchange and updating of information so as to maintain the Contractor's program.
- 20.4.6 The complexity of the Project and the importance of ensuring that the work is executed within time limitations require detailed programming and monitoring of progress so that early program adjustments can be made in order to minimize the effects of potential delays.
- 20.4.7 The coordinator in conjunction with the interface contractors shall identify necessary provisions in the works for plant, equipment and facilities of the Interface contractors. These provisions shall be allowed for by the contractor in his design of the Works.
- 20.4.8 During the course of the Contract, information shall be obtained in a number of ways, including direct inspection, regular Site meetings, the obtaining of progress reports and the use of turnaround documents to obtain design and program data. Turnaround documents shall be issued to the interface contractors to be returned giving the current positions on their program.

20.5 Meetings with External Interfacing Parties and Interfacing Contractors

- 20.5.1 The Contractor shall conduct regular meetings with the external interfacing parties and interface contractors to clarify particular aspects of the interface requirements of the Contract works and the related works. The party who convenes the meeting shall prepare minutes recording all matters discussed and agreed at the meeting. The Contractor shall advise the Engineer in advance the date, time and location of such meetings as they may elect to attend.

20.6 Issuance of Information Related to Interfaces and Coordination

- 20.6.1 The Contractor shall ensure that copies of all correspondence, drawings, meeting minutes, programs etc. relating to the Contractor’s coordination with the interface contractors are issued to all concerned parties and the Engineer no later than two (2) calendar days from the date of such correspondence and meetings.

20.7 Liability for Failed Interfaces

- 20.7.1 Any claim of additional costs by the interface contractors or external interface parties resulting directly from the Contractor's failure to keep to specified dates or due to incorrect or delayed information provided by the Contractor, shall be borne by the Contractor. The Contractor shall note that the information exchange is an iterative process requiring the exchange and updating of information at the earliest opportunity and shall be carried out on a regular and progressive basis in order for the process to be completed for each stage of the Works.

20.8 Design Coordination with Interface Contractors

- 20.8.1 The Contractor shall undertake design coordination with the interface contractors within periods for design interfacing and coordination. The Contractor may commence design interfacing with interface contractors prior to the given period once information has been developed to a level where meaningful interaction can take place. The end of the design interfacing and coordination period indicates the deadline for receipt by the Engineer of a notice from the Contractor and each of the interface contractors stating that design coordination has been completed and that designs have been reviewed to ensure consistency between the designs proposed by the Contractor and the respective related interface contractor. Typically, design interaction shall include the following:
- a. Definition and agreement with interface contractors of interface areas, contract limits, shared loads, physical work interfaces, sequence of installation and/or testing of systems;
 - b. The Contractor shall fully coordinate the design of the Contract works with the design of interface contractors and shall follow the interfacing requirements detailed in the ERT;
 - c. The Contractor shall ensure that the requirements of each interface contractor are fully coordinated and provided for in the design of the Contract Works. The Contractor shall interface and liaise with interface contractors and other contractors in accordance with the requirements of the ERT.
 - d. Definition and design approach by the Contractor with the interface contractors for civil and structural works or type, size and location of equipment and control rooms, access routes thereto, embedded ductwork and other cast-in items such as lifting hooks and eyes, fixing bolts and sockets, agreement of installation programming, preparation of coordinated installation plan etc. shall be done; and
 - e. Combined services drawings, i.e. drawings showing the locations, layouts and sizes of all services, shall be managed, so as to eliminate all clashes with interface contractors’ requirements.

20.9 Construction Interface and Coordination

- 20.9.1 The Contractor shall undertake installation during periods for installation interfacing and coordination. The installation interface and coordination period indicates when its subcontractors and/or interface contractors shall have access to areas within works areas for interface contractors to undertake their work. It shall be incumbent on the Contractor to define more closely with each interface contractor the details of its activities within areas where work is to be carried out and to require the same to be described in interface documents. During the installation interface period, the Contractor shall have priority in working within areas to which access has been granted. The end of the installation interface period indicates when the Contractor shall finish their principal installation work within the given areas to which access has been given.
- 20.9.2 The Contractor shall coordinate and cooperate with the interface contractors on all Site-related matters, including but not limited to Site access and occupation, safety, verification of work compatibility and survey control. The Contractor shall advise the interface contractors in advance when a construction item is ready for field inspection to verify compatibility with the interfacing parties’ needs and shall facilitate access to the Site for the interface contractors.
- 20.9.3 On advice from the interfacing parties that an as-constructed interface-related element is ready for inspection, the Contractor shall:
- a. Conduct on-site inspections of the work elements, and give comments in writing

- to the interface contractors; and
- b. Agree in writing to the interfacing parties that the as-constructed work meets the interface requirements.

20.10 Interface Requirements with External Interfacing Parties

20.10.1 The Contractor shall as and when required interface with other railway disciplines and outside authorities as well as contractual responsibilities with the Employer. These interface requirements and obligations shall include but are not limited to the following:

- a. DOTr;
- b. PNR;
- c. All other railway disciplines (signaling, overhead catenary system, civil, power, communications, Rolling Stock etc.);
- d. Local Authorities (municipalities, barangays etc.);
- e. DPWH;
- f. MERALCO;
- g. Telecom amenity suppliers;
- h. National Telecommunications Commission (NTC) Police Authorities; and
- i. Philippine Government departments (local and national).

20.11 Interface Management Plan

20.11.1 The Contractor shall develop and submit for the Engineer’s review an Interface Management Plan within 42 days following the commencement of the Works, which is mutually acceptable to both the Contractor and the interface contractors. The Interface Management Plan shall:

- a. Identify the equipment as well as the civil works and facilities with interfacing requirements;
- b. Define the authority and responsibility of the Contractor's and Interface Contractors' (and any relevant subcontractors') staff involved in the interface management and development;
- c. Identify the information to be exchanged, precise division of responsibility between the Contractor and interface contractors and integrated tests to be performed at each phase of the Contractor's and interface contractors' works;
- d. After the review of the interface management plan by the Engineer, the Contractor shall execute the works in accordance with the Plan;
- e. Require the Contractor to identify all interfaces with third parties, Subcontractors and the designated Contractor for other packages. The Contractor shall be responsible for liaising with the interface partners;
- f. Establish the methods and procedures used by the Contractor for controlling and ensuring compatibility of physical, functional and environmental interfaces of Contractor-supplied equipment with the Employer’s systems or equipment and other facilities under construction and/or under the control of the Employer;
- g. Establish the requirements, methods and procedures to ensure formal, accountable channels of communication for the exchange of technical information; and

- h. Such methodology shall include both initial definition and formal change information when a change on one side of the interface shall require a corresponding change to the other. After the review of Interface Management Plan by Engineer, the Contractor shall execute the Works in accordance with the plan.
- 20.11.2 The Contractor shall fully coordinate the design of the Contract Works with all relevant bodies and entities, in particular government authorities, departments and regulatory bodies, utility companies, and the consultants and contractors of adjacent projects, whether ongoing or planned.
- 20.11.3 Interface issues and their resolution shall be regularly addressed in the monthly progress report. All submissions shall conform to interface requirements.
- 20.11.4 As a minimum, the IMP shall contain the content as in Table 20.1 below. The intention of each section of IMP is described by the text inside the right-hand column in italics.
- 20.11.5 In the event of delay in the procurement of interface contractor or other parties, the Employer shall be responsible in providing the interface related information to the Contractor.

Table 20.1 Interface Management Plan

1	Introduction	
1.1	Purpose of the Document	Describe the methodology to be adopted by the Contractor in managing all interface issues
1.2	Overview	Project overview of the Contractor and interface contractor interfaces
2	Resource Management	
2.1	Organization and roles & responsibilities	Description of organization structure
2.2	Resource requirements	Detailed description of the personnel, tools, logistics that shall be included in this section
3	Interface Requirements	
3.1	Allocation of interface requirements	This is an introduction to Section 3.2 below
3.2	Interface description between contractors	Task Allocation Table (TAT) shall be included in this section
3.3	Areas of concern	Process for managing the interface concerns
4	Process Management	

4.1	Change of interface requirements	The process for the management of interface requirement change shall be addressed in this section
4.2	Verification and validation of interface requirements	The approach to be adopted by the Contractor to manage verification and validation of interface requirements shall be addressed in this section
4.3	Testing and commissioning on interfaces	The approach to be adopted by the Contractor for the management of interface in the Testing and Commissioning stage shall be addressed in this section
4.4	Quality procedures	Contractor’s internal quality procedures applicable for the interface management shall be listed here
5	Document Management	
5.1	Reference documents	All applicable reference documents shall be listed in this section
5.2	Structure of reference documents	The structure of reference documents shall be addressed in this section
5.3	Version control of interface documents	Configuration management of interface documents shall be addressed in this section
6	Communication	
6.1	Terms of reference of interface meetings	The terms of reference of interface meetings shall be addressed here
6.2	Exchange of information between contractors	The process for the exchange of information between the pair-wise contractors (interface contractors) shall be stated here
6.3	Submission to Engineer	The approach to be adopted by the pair-wise contractors on the submission of the Interface Management Plan to the Engineer shall be described here

6.4	Request for Employer Attention	The criteria and methodology on requesting for the Employer’s attention shall be mentioned here.
-----	--------------------------------	--

20.11.6 Once the Interface Management Plan has been reviewed by the Engineer and the Contractor, the Contractor shall develop and submit to the Engineer for review a detailed interface document for each other contractor that is mutually acceptable to all interfacing contractors. The detailed interface document shall address in detail how the dates identified in the Interface Management Plan shall be achieved and shall identify the data required by the interfacing designated contractors to meet the contractual requirements.

20.11.7 The interface requirements shall form the basis of the detailed interface document, but does not relieve the Contractor's obligation to identify any new interface to meet the Contract requirements. Any revision to the detailed interface document shall be mutually acceptable by the contractors on all sides and submitted to the Engineer for review.

20.12 Clarification of Design, Supply and Fixing of Items

20.12.1 The Contractor must adhere to the requirements under Appendix B of this General Requirements.

(This page is intentionally left blank)

APPENDIX TO GENERAL REQUIREMENTS

TABLE OF CONTENTS

Appendix A: Definitions and Abbreviations

Appendix B: Split Responsibility on Rolling Stock and Other Works

Appendix C: (Not Used)

Appendix D: Work Programme Reference

(This page is intentionally left blank)

Appendix A: Definitions and Abbreviations

This section defines the terms used in this General Requirements and, Technical Requirements for Rolling Stock.

Table A.1 Definitions

Original terms	Definition
Applicable Laws	The governing laws and regulations in force in the Philippines.
As-Built Drawings	Drawings produced by the Contractor and endorsed by the Engineer as true records of the construction of the Permanent Works and which have been agreed with the Engineer, if the Employer’s Design is changed during the course of the Works, the As-built Drawings shall be prepared by the Contractor and endorsed by the Engineer.
ATO Operation	Train operated under ATO.
ATP Mode (Train Operation)	The mode of train operation when train speed is controlled manually but is supervised by the primary ATP system to ensure safety speed limits are not exceeded
Combined Services Drawings	Drawings showing the locations, layouts and sizes of all services including those of the Contractor, and the interfaces with interface contractors, so as to eliminate all clashes.
Commencement Date	The date specified in the Contract, or by some other arrangement with the Employer, upon which operations and activities required for the execution of the Works are to commence.
Commissioning	The process of setting to work relevant electrical and mechanical elements of the building services or complete transportation system through a series of integrated tests that demonstrate the installation and performance in accordance with the specified criteria.
Consist	Any collection of cars, serviceable and operable, of minimum 2 vehicle length and maximum 8-vehicle length with a cab at each end
Consumables	those parts that are not repairable and usually have a relatively short life span.
Contract Completion Date	the date specified in the Contract upon which the Works are to be completed and handed over to the Employer.
Defects Notification Period	Period for notifying Defects in the works calculated from the date on which the works completed as certified by taking over certificate.
Detailed Works Program	The Contractor’s Works program, showing the sequence, design, manufacture, delivery to the site, erection, construction, installation, testing, commissioning of the works and related activities in the form and content prescribed by the specification, or any amended or varied version thereof, as submitted by the Contractor and given Notice of No Objection by the Engineer in accordance with the Contract.
Disadvantaged Persons	Passengers who are physically handicapped or have physical difficulty. These shall include senior citizens, the blind, people in wheelchairs, pregnant woman, and the like.
Dwell Time	The elapsed time from when a train stops alongside a platform until it starts again.

Original terms	Definition
Execution of the Works	The manufacture, supply, transportation, delivery to the Site, construction, erection, installation, testing, commissioning, performance testing, completion, and training in the use of the Works in accordance with the Contract; the preparation and/or delivery (as appropriate) of all information, drawings and manuals in respect of the Works required by the Contract, the provision of such spare parts, consumables, tools and spare materials as are required by the Contract to be provided by the Contractor for the performance of its defects liability obligations, and the management of all such matters.
External Interfacing Parties	Those parties with whom it is the Contractor’s responsibility to coordinate the Works with and includes all relevant bodies and entities, in particular Government authorities, departments and regulatory bodies, utility companies, property developers, consultants, and contractors of adjacent projects (other than MCRP and NSRP-South), whether ongoing or planned. The Contractor shall identify all such interfacing parties in the Interface Management Plan (IMP).
Interface Contractors	The Contractors, other than the Contractor, engaged by the Employer, who are undertaking works on the other MCRP and NSRP-South contract packages. The Contractor shall identify all such interface contractors in the interface management plan.
LGU	A Local Government Unit, which refers to the local council or administrative body for a geographical area.
Main Line	All tracks over which trains carry fare paying passengers, including all berths, plus sidings and connections between, up to the limits leading into a yard.
Manual Operation	Train operated by operator under one of the following modes: ATP, ROS, RM or ATP Cut-out modes.
Project: MCRP and NSRP-South	Railway projects which extend North-South Commuter Rail Project for north and south, which is the entirety of the project for which this specification applies and which the Works shall construct.
GCR	General Consultant for MCRP and NSRP-South
Operational Mean Time to Restore (OMTTR)	Is defined as the average time to restore/normalize Rolling Stock with a fault on the main line
Spare Parts	Those parts which are generally repairable and normally have a service life of several years.
Taking Over	The point where the Works or any part thereof has passed all relevant tests and can be Taken-Over by the Employer in accordance with the GC and PC, notwithstanding the Works may have certain outstanding minor works to be completed, but nonetheless such shall not affect the Employer’s beneficial use of the Works or part as intended by the Contract.

This section lists out all the abbreviations used in the ERG and ERT.

Table A.2 Abbreviations

Abbreviation	Original terms
μsec	Micro Second
°C	Degree Celsius
A or Amp	Ampere
ABS	Anti-lock Braking System
AC or ac	Alternate Current
ACU	Air-Conditioning Unit
AIDS	Acquired Immune Deficiency Syndrome
ANSI	American National Standards Institute
APSE	Auxiliary Power Supply Equipment
ASHRAE	The American Society of Heating, Refrigerating and Air-Conditioning Engineers
ATC	Automatic Train Control
ATO	Automatic Train Operation
ATP	Automatic Train Protection
AUGT	Automatic Urban Guided Transport
BCU	Brake Control Unit
BDS	Bid Data Sheet
BF	Bidding Forms
BFP	Bureau of Fire Protection
BOQ	Bill of Quantities
BS	British Standards
CAD	Computer Aided Design
CAR	Corrective Action Request
CBT	Computer-Based Training
CBTC	Communications Based Train Control
CCTV	Closed Circuit Television
CEMS	Crash Energy Management System
CENELEC	European Committee for Electro Technical Standardization
CF	Contract Forms
CMMS	Computerized Maintenance Management System
CMTTR	Corrective Mean Time To Repair
CPM	Critical Path Method
CSM	Common Safety Method
Days	Calendar days including all weekends
dB (A)	Decibel, A-weighted
DC or dc	Direct Current
DID	Detail Interface Design
DIIT	Dynamic Integrated Interface Test
DOLE	The Philippines' Department of Labor and Employment

Abbreviation	Original terms
DOTr	Department of Transportation
DNP	Defects Notification Period
DRACAS	Data Reporting Analysis and Corrective Action System
ED	End Device
EDMS	Electronic Document Management System
E&M	Electrical & Mechanical
EMC	Electro-Magnetic Compatibility
EMI	Electro Magnetic Interference
EMP	Environmental Management Plan
EN	European Norm
EQC	Evaluation and Qualification Criteria
ER	Employer’s Requirements
ERG	General Requirements
ERT	Technical Requirements
ESC	Eligible Source Countries of Japanese ODA Loans
ETFE	Ethylene Tetrafluoroethylene Fluoropolymer
FACI	First Article Configuration Inspection
FAT	Factory Acceptance Tests
FEM	Finite Element Model
FFR	Fault Free Run
FIS	Fault Indication System
FMECA	Failure Mode, Effects and Criticality Analysis
FMI	Field Modification Instruction
FTA/ETA	Fault Tree Analysis/ Event Tree Analysis
GC	General Conditions
GSM(R)	Global System for Mobile Communications(Railway)
HIV	Human Immunodeficiency Virus
HMI	Human Machine Interface
HSCB	High Speed Circuit Breaker
HV	High Voltage
Hz	Hertz
IEC	International Electromechanical Commission
IFAT	Integrated Factory Acceptance Test
IFBT	Integrated Factory Bench Test
IGBT	Insulated Gate Bipolar Transistor
IMP	Interface Management Plan
IP	Ingress Protection
IPC	Illustrated Parts Catalogs

Abbreviation	Original terms
ISA	Independent Safety Assessor
ISO	International Organization for Standardization
ITB	Instructions to Bidders
ITCP	Inspection, Testing and Commissioning Plan
ITU	International Telecommunication Union
ITU-R	ITU Radio Communication Sector
ITU-T	ITU Telecommunication Standardization Sector
JICA	Japanese International Cooperation Agency
JRIS	Rolling Stock Industrial Standard
kg	Kilogram
km	Kilometer
km/h	Kilometers per hour
kN	Kilonewton
kV	Kilovolt
kW	Kilowatt
LB	Line Breaker
LGUs	Local Government Units
LCD	Liquid Crystal Display
LED	Light Emitting Diode
LLRU	Lowest Line Replaceable Units
LTE(4G)	Long-Term Evolution (Fourth Generation)
LVPS	Low Voltage Power Supply
m²	Square meter
m/s²	Meters per square second
m/s³	Meters per cubic second
MDBF	Mean Distance Between Failure
MLIT	Ministry of Land, Infrastructure, Transport and Tourism
mm	Millimeter
MMDA	Metro Manila Development Authority
MMS	Maintenance Management System
MPa	Megapascal (Pressure Unit)
MSDS	Material Safety Data Sheet
ms	Milisecond
MWI	Maintenance Work Instruction
N	Newton
NAIA	Ninoy Aquino International Airport
NDT	Non Destructive Tests
NGOs	Non-Government Organizations
NSCR	North-South Commuter Railway
NSRP-South	North-South Railway Project-South line
NTC	National Telecommunications Commission
NTO	Non-automated Train Operation

Abbreviation	Original terms
O&M	Operation and Maintenance
OCC	Operation’s Control Center
OCS	Overhead Catenary System
ODA	Official Development Assistance
OEM	Original Equipment Manufacturer
OH&S	Occupational Health and Safety
OMTTR	Operation Mean Time To Restore
OS	Operating System
PA	Public Address
PAC	Performance Acceptance Criteria
PAGASA	Philippine Atmospheric, Geophysical and Astronomical Services Administration
PAP	Performance Assurance Plan
PCC	Particular Condition of Contract
PDM	Precedence Diagram Method
PCE	Power Conversion Equipment
PEC	Philippine Electrical Code
PECE	Power Electronics Control Equipment
PEI	Passenger Emergency Intercom
PERT	Program Evaluation and Review Technique
PID	Platform Information Display
PLC	Programmable Logic Processor
PID	Passenger Information Display
PMP	Project Management Plan
PNR	Philippine National Railways
PNS	Philippine National Standards
PPE	Personal Protective Equipment
PR	Public Relation
PTT	Press to Talk switch
PTU	Portable Test Unit
QMP	Quality Management Plan
RAM	Reliability, Availability & Maintainability
RFI	Request For Information
RFI	Radio Frequency Interference
RM	Restricted Manual
ROS	Running On Sight
RS	Rolling Stock
SAMP	System Assurance Management Plan
SAP	Systems Assurance Plan
SAT	Site Acceptance Test
SBD	Safe Braking Distance
SHE	Safety, Health and Environment
SI	Le Système International d'Unités (International System of Unit s)

Abbreviation	Original terms
SIFIT	Static Integrated Factory Interface Test
SIL	Safety Integrity Level
SIT	System Integration Tests
SMP	Site Management Plan
SOW	Scope of Works
SSAMP	System Safety Assurance Management Plan
SSMP	Site Safety Management Plan
STI	Speech Transmission Index
STO	Semi-automatic Train Operation
SUV	Sport Utility Vehicle
t	Ton
T&C	Testing and Commissioning
TCN	Train Communication Network
TFE	Tetrafluoroethylene
TMS	Train Management System
TOC	Taking Over Certification
TOCP	Train Operator Control Panel
ERT	Technical Requirements
UIC	International Union of Railway Standards
UL	Underwriters’ Laboratories
UPS	Uninterruptible Power Supply
UV	Ultra Violet (Light Spectrum 400 Nm to 100 Nm)
V&V	Verification and Validation
V ac	Voltage alternative current
V dc	Voltage direct current
VAC	Ventilation and Air-Conditioning
VDT	Visual Display Terminals
Vnom	Nominal Voltage
Vpk	Peak Voltage
VS	Vehicle Switch
VVP	Verification and Validation Plan
VVVF	Variable Voltage Variable Frequency
V-LAN	Virtual LAN
W0	Vehicle Tare Weight
W1	W0 + Seated Passenger
W2	W1 + 4 passenger/meter standee
W3	W1 + 7 passenger / meter standee
W4	W3 + dynamic load and safety margin
WBS	Work Breakdown Structure
XLPO	Cross-linked polyolefin

Appendix B: Split Responsibility on Rolling Stock and Other Works

1. Clarification of Design, Supply and Fix Items.

The Contractor shall prepare the detailed interface document in order to coordinate with the interface contractors in the construction/installation works as mentioned in the ERG and ERT. The Contractor shall include, but not be limited, to the following design requirement, design, supply and fix items:

The Contract Package shall be stated as follow:

- 1) CP N-01~04: CIVIL Works
- 2) CP N-05: DEPOT Works
- 3) CP S-01~06: CIVIL Works
- 4) CP S-07: DEPOT Works
- 5) CP NS-02: Rolling Stock – Commuter Trainsets;
- 6) CP NS-03: Rolling Stock – Limited Express Trainsets; and
- 7) CP NS-01: E&M Systems and Track Works.

Table B.1 Interface Responsibility Matrix

No.	Interface Item	Design Requirement	Design, Size & Location	Supply	Fix	Remarks
1	Description of on-board Signaling & Communication Equipment’s but not limited to the following: 1) On-board signaling system racks/cubicles 2) Wheel sensors SIG 3) Accelerometer SIG 4) Radar SIG 5) Antenna SIG 6) On boards data communication System (DCS) for ETCS Level 2 (900MHz frequency for ETCS Level 2 to be confirmed) 7) Driver Machine Interface SIG 8) Cables for interlink with signaling equipment 9) Cable connectors for signaling equipment 10) Train Radio- com 11) Antenna- com 12) Antenna cable - com 13) Connectors for communication equipment	CP NS-01	CP NS-01 and CP NS-02	CP NS-01	CP NS-02 Installation on the first train-set is supervision by CP NS-02 & CP NS-01 Contractors.	CP NS-01 and CP NS-02 Contractors shall coordinate and agree on the size, space and location.

No	Interface Item	Design Requirement	Design, Size & Location	Supply	Fix	Remarks
2	Cable description but not limited to the following: 1) Power supply cable for train radio 2) Power supply cable for Signaling & Communication equipment 3) Cables for train lines to signaling equipment 4) Power supply cable for Advertising Equipment.	CP NS-01	CP NS-01 and CP NS-02	CP NS-02 and CP NS-01	CP NS-02	CP NS-01 and CP NS-02 Contractors shall coordinate and agree on the size and location
3	Fixtures and Fittings: Disconnection and terminal blocks, device mounting brackets and plates, flexible conduit assemblies complete with connectors and cables from speed measurement devices to the junction boxes.	CP NS-01	CP NS-01 and CP NS-02	CP NS-02 and CP NS-01	CP NS-02 Installation on the first train-set is supervision by CP NS-02 & CP NS-01 Contractors.	CP NS-01 and CP NS-02 Contractors shall coordinate and agree on the size and location
4	Power Supply and Earthing Arrangements: Power supply circuits, including positive and negative poles, for the on-board signaling equipment. Dedicated earthing arrangements for the on-board signaling equipment	CP NS-01	CP NS-01 and CP NS-02	CP NS-02	CP NS-02 Installation on the first train-set is supervision by CP NS-02 & CP NS-01 Contractors.	
5	Overhead Catenary System (OCS): OCS height, staggering, sag and other required	CP NS-01 and CP NS-02	CP NS-01	CP NS-01	CP NS-01	CP NS-01 and CP NS-02 Contractors shall coordinate

No	Interface Item	Design Requirement	Design, Size & Location	Supply	Fix	Remarks
	parameters with reference to the Rolling Stock supplied pantograph.					and agree on the OCS height, staggering, sag and other required parameters with reference to the Rolling Stock supplied pantograph.
6.	Computerized Maintenance Management System (CMMS) consisting of software and hardware for the planning and management of all maintenance work and associated function, including but not limited to following: Assets Management, Material Management, Maintenance Schedule, work order, Maintenance Record, failure log etc.	CP NS-01 and CP NS-02	CP NS-01	CP NS-01	CP NS-01	CP NS-01 and CP NS-02 Contractors shall coordinate and agree for the CMMS requirements and CP NS-02 shall provide all the necessary required data for CMMS.
7	Voltage Drop in Traction System and Rectifier Capacity	CP NS-01 and CP NS-02	CP NS-01	CP NS-01	CP NS-01	CP NS-01 and CP NS-02 Contractors shall

No	Interface Item	Design Requirement	Design, Size & Location	Supply	Fix	Remarks
						coordinate and exchange the information.
8	The CP NS-02 shall provide six (6) units of couplers and deliver to the CP NS-01 Contractor	-	-	CP NS-02	CP NS-01	CP NS-01 & CP NS-02 Contractors shall coordinate and exchange the information for schedule of delivery, location and other related requirements (if any).

Please note that design requirement mentioned above are not exhaustive, Contractor shall further elaborate the requirements in close coordination with interface Contractors. Associated interfaces works not mentioned in the above table but which may be inferred to be necessary for stability, or completion, or effective interface & integration or the safe reliable and efficient operation of the Works shall be carried out by the Contractor. The Interface work shall include any work which is necessary to satisfy the Employer’s Requirements, the Contractor’s proposal and schedules, or is implied by the Contract, or arises from any obligation of the Contractor and shall be fit for the purposes for which they are intended.

Table B.2: Split Responsibility in Special Tools for Rolling Stock and Depot Equipment

ITEM	DESCRIPTION	SUPPLY
1	Workshop Facilities	
1.1	Turn table for bogie	CP NS-01
1.2	Lifting jack for car body	CP NS-01
2	Testing Equipment	
2.1	Portable test unit for traction controller (with software)	CP NS-02
2.2	Portable test unit for auxiliary power supply equipment (with software)	CP NS-02
2.3	Portable test unit for air conditioning unit (with software)	CP NS-02
2.4	Portable test unit for brake control unit (with software)	CP NS-02
2.5	Portable test unit for TMS (with software)	CP NS-02
2.6	Test equipment for ACU	CP NS-02
2.7	Test equipment for brake control unit	CP NS-02
2.8	Testing equipment for relays	CP NS-01
2.9	Testing equipment for magnetic valves	CP NS-01
3	Jigs/Test Stands	
3.1	Test stands for bogie	CP NS-02
3.2	Lifting jig for ACU	CP NS-02
3.3	Test stand for ACU	CP NS-02
4	Machining Tools	
4.1	Wheel re-profiling machine	CP NS-01
4.2	Wheel lathe	CP NS-01
5	Tools for Maintenance Work	
5.1	Refrigerant retainer	CP NS-02

5.2	Not used.	CP NS-02
5.3	Window glass lifting fixture (vacuum)	CP NS-02
5.4	Crimping tool for electric connector (for each equipment)	CP NS-02
5.5	Wrenches	CP NS-01
5.6	Power supply for testing electrical equipment	CP NS-01
5.7	Welding machine	CP NS-01
5.8	Soldering iron	CP NS-01
6	Cleaning Facilities	
6.1	Train washing plant	CP NS-01
6.2	Parts washer	CP NS-01
7	Measuring Tools	
7.1	Digital multi-meter	CP NS-01
7.2	Ohmmeter	CP NS-01
7.3	Wheel diameter measuring equipment	CP NS-02
7.4	Back gauge measuring equipment	CP NS-02
7.5	Wheel profile gauge	CP NS-02
7.6	Coupler head wear gauge	CP NS-02
7.7	Leak detector for refrigerant	CP NS-02
7.8	Tension gauge for measuring upward force of pantograph	CP NS-01
7.9	Vacuum pump for refrigerant	CP NS-01
8	Transportation Equipment	
8.1	Shunting vehicle	CP NS-01
8.2	Truck for transporting air conditioning unit	CP NS-01

Appendix C: (Not used)

Appendix D: Work Programme Reference

APPENDIX D: WORK PROGRAMME REFERENCE

1 Time Scaled Network/ Bar Chart

- 1.1 The coding structure shall be such that the activities can be summarized to the various levels. The Contractor shall comply with the Employer’s Work Breakdown Structure (WBS), Activity codes, Activity ID, etc. Refer to the Tables shown in this Appendix for the detail on WBS and Activity Codes. The Contractor is allowed to propose further breakdown and additional codes for project use upon the review and approval by the Employer or the Engineer. Each activity in the network shall be coded, as a minimum, with the following:
 - (1) Contract number, activity type, and unique identification numbers,
 - (2) Activity codes to indicate Unit, Segment, Stage or Phase, for e.g. design, manufacturing, delivery, installation, etc., and
 - (3) The Contractor shall note that breakdown of system into sub-systems is essential and shall be carried out not through further coding but through activity descriptions in a consistent manner.
 - (4) For more details, the Contractor can refer to the Employer’s Planning and Schedule Manual.
- 1.2 All logical and necessary relationships between activities shall be shown.
- 1.3 All key dates (if any) indicated in the Contract shall be shown. In addition to the key dates, the Contractor may require certain events that are critical to his work to be reflected in his programs as “milestones”.
- 1.4 All the activities shall be loaded with associated cost in accordance with Accepted Contract Amount (ACA) and Bill of Quantity (BOQ). A S-Curve should be generated accordingly to demonstrate the physical progress throughout the project period. A cashflow shall be prepared based on the forecast progress and contract terms & conditions.
- 1.5 If payment milestones are applicable for the contract, all the payment milestones shall be created and allocated with agreed amount. A cashflow shall be generated accordingly.
- 1.6 The level of program development, information and detail shall be sufficient to permit the Engineer to have a good appreciation of the Contractor's project management plan especially with regard to the co-ordination and timing of his work in relation to the work of the Interface Contractors and the obtaining of necessary approvals from the relevant local authorities. It shall demonstrate ability to meet specified key dates through a logical work sequence that has taken account of the Project constraints.
- 1.7 Activities pertaining to review/acceptance by the Engineer and local authorities shall be identified. Where duration for review of the Contractor's submissions are specified elsewhere in the Contract, they shall be used.
- 1.8 Activities outside the scope of the Contract that may affect the Contractor's progress shall be shown.
- 1.9 The activity network shall be organized so that major work sections are carefully coordinated with Interface Contractors to allow opportunity for all to work with as minimal disruption as possible. Critical paths shall be identified.
- 1.10 Activity descriptions shall be brief and shall convey the nature and scope of the work. Uncommon abbreviations shall be explained in the legend. Float time shall be distinguished from schedule performance.
- 1.11 The CPM Network Diagram shall be developed to permit modification to the schedule

and allow for impacts on the schedule to be analyzed by introduction of "what if" statements into the input data.

- 1.12 The constraint shall be applied to only the Key Dates and Access Dates for calculating the floats. All the schedule assumption shall be described and schedule lag shall be explained in the narrative.

2 Time Scaled Network/Bar Chart Details

- 2.1 Mobilization: The mobilization network/bar chart shall include key personnel, major team, major subcontractors, and setup of office, camp, plant & equipment, as well as the early procurement for long lead time items. In general, for those activities shall be carried out within first 120 days after the commencement of works, but not specific to the following phases.
- 2.2 Design: The design network/bar chart shall detail the various design, submission and acceptance stages including approval by local authorities (if any) and no objection from the Engineer, preparation, submission and no objection of drawings, manuals and all other activities related to the design.
- 2.3 Manufacturing: The manufacturing network chart shall indicate the relationship and duration of the activities necessary to procure, fabricate, manufacture assemble equipment/complete car tests, ship and deliver rolling stock in time to support the activities at the Site. It shall establish milestones for monitoring the progress of the manufacturing process. The network shall also cover activities of Subcontractor as appropriate, including testing.
- 2.4 Construction and Installation: The on site construction and installation activities shall detail the relationship and duration of the activities required for preparing, constructing, erecting, cabling all the Civil, MEP Trackwork, System works in the final location as per the drawings. The interface should be identified if multiple contractors have to carry out their works in parallel / in specific sequence at the same site throughout a period. Certain intermediate milestones could be added to monitor and measure the key achievement.
- 2.5 Testing, commissioning and acceptance: The factory and on-site testing and commissioning activities shall present the relationship and duration of those items relating to commissioning tests including those related to the Interface Contractors. The network/bar chart shall present testing approach and sequence to be used, the deployment of resources in accordance with signaling milestone dates.
- 2.6 Integrated testing: The integrated testing network/bar chart shall indicate the activities required to verify the functioning of all subsystems and the rolling stock in conjunction with activities of the Interface Contractors.
- 2.7 Trial Runs: After completion of commissioning, the Contractor shall be required to take part in trial runs with other interface contractors as decided. The network/chart shall indicate tests, measurements and interface tests required to be carried out to verify system performance and readiness for revenue service.

3 Program Standards

- 3.1 All the programs shall be prepared, monitored, updated and revised based on good project planning, scheduling and monitoring practices as accepted internationally, and under guidance of ISO 21500 – 2012.

Table D - 1: DOTr Primavera Cloud – Schedule Work Breakdown Structure (WBS) Page 1 of 2

Primavera Cloud - Work Breakdown Structure (WBS)				
Structure	Level	Status	Description	Values
Work Breakdown Structure	L01	Client defined	Contract	Predefined by DOTr
	L02		Stage	Predefined by DOTr
	L03		Location	<i>As applicable (to be reviewed / approved by DOTr/GCR)</i>
	L04		Disciplines & Systems L1 - aligned to BOQ	Predefined by DOTr
	L05		Disciplines & Systems L2 - aligned to BOQ	Predefined by DOTr
	LNN	Optional	<i>As applicable</i>	<i>As applicable (to be reviewed / approved by DOTr/GCR)</i>

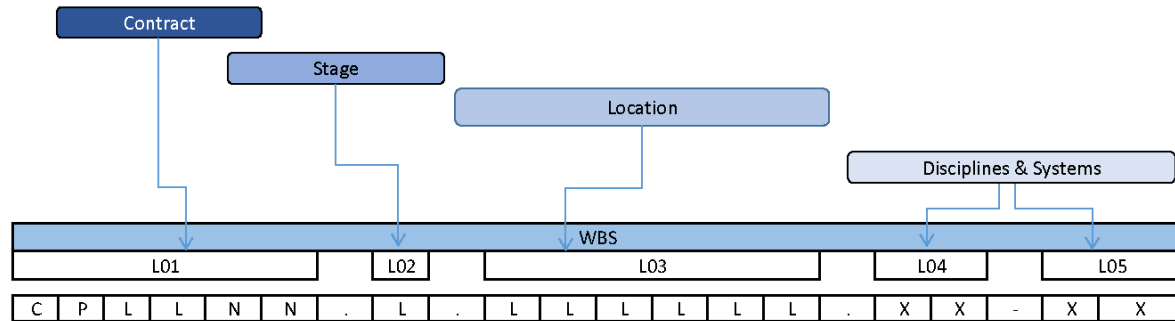

Table D - 2: DOTr Primavera Cloud – Schedule Work Breakdown Structure (WBS) Page 2 of 2

Example:

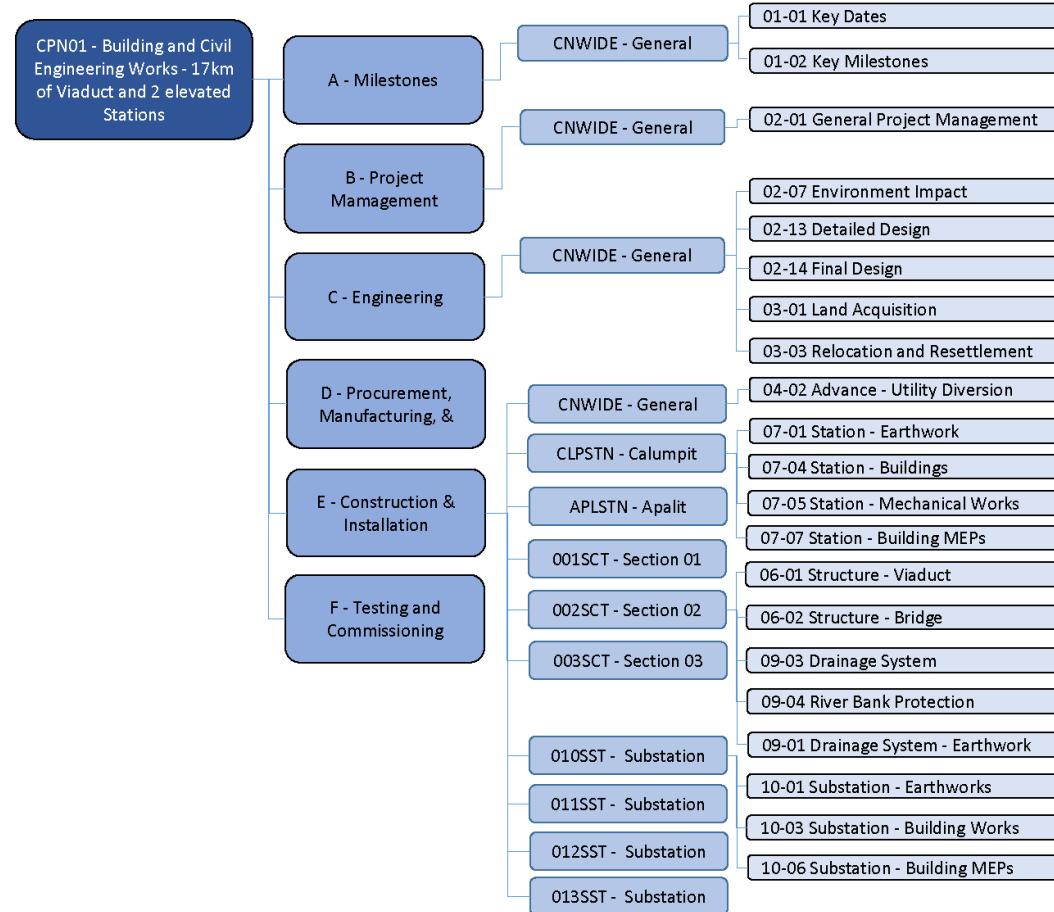

Table D - 3: DOTr Primavera Cloud – Schedule WBS Dictionary Page 1 of 7

Work Breakdown Structure (WBS) Dictionary (Level 1 to Level 5)

WBS Level 1 - Contract										
C	P	L	L	N	N	Description				Remarks
C	P		O	0	1	Building and Civil Engineering Works				
C	P		O	0	2	Building and Civil Engineering Works				
C	P		O	0	3	Rolling Stock - Commuter Trainsets				
C	P		O	0	4	E&M Systems and Track Works				
C	P		O	0	5	Building and Civil Engineering Works				
C	P		N	0	1	Building and Civil Engineering Works - 17km of Viaduct and 2 elevated Stations				
C	P		N	0	2	Building and Civil Engineering Works - 16km of Viaduct and 1 elevated Stations				
C	P		N	0	3	Building and Civil Engineering Works - 16km of Viaduct and 2 elevated Stations				
C	P		N	0	4	Building and Civil Engineering Works - 6.5km of mainline and 1.1km depot access line, 1 U				
C	P		N	0	5	Building and Civil Engineering Works - Depot (approx. 33ha)				
C	P		S	0	1	Building and Civil Engineering Works - 1.1 km of Viaduct and 1 Elevated Station				
C	P		S	0	2	Building and Civil Engineering Works - 7.9 km of Viaduct and 3 Elevated Station				
C	P		S	3	a	Building and Civil Engineering Works - 4.5 km of Viaduct, Atgrade, 1 atgrade Station and 1				
C	P		S	3	b	Building and Civil Engineering Works - 10.7 km of Viaduct, Atgrade, 1 semi U/G, 1 atgrade				
C	P		S	0	4	Building and Civil Engineering Works - 8.5 km of Viaduct and 2 Elevated Station				
C	P		S	0	5	Building and Civil Engineering Works - 12.8 km of Viaduct and 3 Elevated Stations				
C	P		S	0	6	Building and Civil Engineering Works - 10.3 km of Viaduct and 3 Elevated Stations				
C	P		S	0	7	Building and Civil Engineering Works - Depot (Approx. 20ha)				
C	P	N	S	0	1	E&M Systems and Track Works including PSD at all NSCR stations				
C	P	N	S	0	2	Rolling Stock-Commuter Trainsets (38 trainsets consisting of 8 cars, total 304 cars)				
C	P	N	S	0	3	Rolling Stock-Limited Express Trainsets (7 trainsets consisting of 8 cars, total 56 cars)				
						To be added when new contract is initiated				
WBS Level 2 - Stage (EPC/D&B phases)										
					L	Description				Remarks
					A	Milestones				
					B	Project Management				
					C	Engineering (Concept, Preliminary, Detailed, Final, ICD, NOC etc)				
					D	Contract & Procurement (including manufacturing & delivery)				
					E	Construction & Installation				

Table D - 4: DOTr Primavera Cloud – Schedule WBS Dictionary Page 2 of 7

C	P	L	L	N	N	Description	Remarks
					F	Testing & Commissioning (static, interface, dynamic, integration, Trial Operation)	
					G	Operation & Maintenance	
WBS Level 3 - Location / Section / Construction Front							
L	L	L	L	L	L	Description	Remarks
Pre-defined by DOTr							
P	R	W	I	D	E	Program Wide	
N	1	W	I	D	E	N1 Wide	
N	2	W	I	D	E	N2 Wide	
S	C	W	I	D	E	SC Wide	
C	N	W	I	D	E	General (Contract Wide)	
A	L	A	S	T	N	Station - Alabang	
A	N	G	S	T	N	Station - Angeles	
A	P	L	S	T	N	Station - Apalit	
B	A	L	S	T	N	Station - Balagtas	
B	A	N	S	T	N	Station - Banlic	
B	C	T	S	T	N	Station - Bicutan	
B	I	N	S	T	N	Station - Binan	
B	L	U	S	T	N	Station - Blumentritt	
B	O	C	S	T	N	Station - Bocaue	
B	C	L	S	T	N	Station - Bucal	
B	U	E	S	T	N	Station - Buendia	
C	B	Y	S	T	N	Station - Cabuyao	
C	M	B	S	T	N	Station - Calamba	
C	A	L	S	T	N	Station - Caloocan	
C	L	P	S	T	N	Station - Calumpit	
C	R	K	S	T	N	Station - Clark	
C	I	A	S	T	N	Station - Clark International Airport	
E	D	S	S	T	N	Station - EDSA	
E	S	P	S	T	N	Station - Espana	
F	T	I	S	T	N	Station - FTI	
G	U	I	S	T	N	Station - Guiguinto	
M	A	B	S	T	N	Station - Mabalacat	
M	L	B	S	T	N	Station - Malabon	
M	A	L	S	T	N	Station - Malolos	
M	L	S	S	T	N	Station - Malolos South	
M	A	R	S	T	N	Station - Marilao	
M	E	Y	S	T	N	Station - Meycauayan	
M	T	N	S	T	N	Station - Muntinlupa	
N	C	1	S	T	N	Station - New Clark City 1	
N	C	2	S	T	N	Station - New Clark City 2	

Table D - 6: DOTr Primavera Cloud – Schedule WBS Dictionary Page 4 of 7

C	P	L	L	N	N	Description	Remarks
N	N	-	N	N		Description	Remarks
0	1					Project Key Dates & Milestones	
0	1	-	0	1		Key Dates	
0	1	-	0	2		Key Milestones	
0	1	-	0	3		Payment Milestones	
0	1	-	0	4		Other Milestones (Interface/Intermediate/not defined in the contract)	
0	2					General and Consultancy Services	
0	2	-	0	1		General Project Management (General Requirements)	Level 5 is aligned to General Requirement in BOQ
0	2	-	0	2		Data Collection & Concept Design	Level 6
0	2	-	0	3		Geotechnical	Suggest to be aligned to the further breakdown (As per GS No.) in BOQ
0	2	-	0	4		Land Based Survey	GS No. Description - some examples below
0	2	-	0	5		Aerial Survey	103 Possession of Site and Contractors Mobilization
0	2	-	0	6		Business Modeling	104 Contractor's Temporary Facilities
0	2	-	0	7		Environment Impact Assessment	105 Project Information Sign Boards
0	2	-	0	8		Material Testing	106 Laboratory
0	2	-	0	9		Interface coordination and management	107 Contractor's Project Organization and Management
0	2	-	1	0		Specialist Design Consultancies	108 Site Office for the Employer and the Engineer
0	2	-	1	1		Safety, Risk, Security, RAMS Services	110 Detailed Works Programme
0	2	-	1	2		Preliminary Engineering	112 Surveying, Setting out of the Works and Staking
0	2	-	1	3		Detailed Design and Engineering	114 Traffic Management
0	2	-	1	4		Final Design and Shop Drawings	118 Environmental Management
0	2	-	1	5		Legal Services	119 Document and Drawing Submittals and Reviews
0	2	-	1	6		Meteorology & Seismology (incl Weather & Climate) Services	120 Submission and Response Procedure
0	3					RAP (Resettlement Action Plan)	121 Operating and Maintenance Manuals and Documents
0	3	-	0	1		Land Acquisition (Paper works for utility relocation and tree permits)	122 Construction Photographs
0	3	-	0	2		LRIP (Likelihood Restoration and Improvement Program)	123 Video Recordings
0	3	-	0	3		Relocation and Resettlement (proeject affected people)	130 Securities and Insurance
0	3	-	0	4		GRM (Grievances Redress Mechanism)	
0	4					Advance & Enabling Works	
0	4	-	0	1		Demolition	
0	4	-	0	2		Utility Diversion (or Protection)	
0	4	-	0	3		Relocation of Existing Facilities	
0	5					Earthworks	
0	5	-	0	1		Earthworks	
0	5	-	0	2		Maintenance Road/Access Road	
0	5	-	0	3		Existing Road Realignment	
0	5	-	0	4		Swampy Section	
0	5	-	0	5		Subbase and Base Course	
0	5	-	0	6		Surface Course	

refer to N-01 to N-05 BOQ

Table D - 7: DOTr Primavera Cloud – Schedule WBS Dictionary Page 5 of 7

C	P	L	L	N	Description	Remarks
0	5	-	0	7	Structural Works	
0	5	-	0	8	Miscellaneous Structures	
0	5	-	0	9	Plumbing and Sanitary Works	
0	6	-			Railway Structures	
0	6	-	0	1	Viaduct	Level 6 Suggest to be aligned to the further breakdown in BOQ
0	6	-	0	2	Bridges (Underbridge, Overbridge, etc)	Earthwork
0	6	-	0	3	Underground Structures (Cut & Cover Tunnel, Bored Tunnel, Underpass etc)	Sub-Structural and Superstructural Works
0	6	-	0	4	At Grade Structure	Drainage Works (In Viaduct)
0	6	-	0	5	Utility Corridor	Miscellaneous Works
0	6	-	0	6	Box Culvert	
0	7	-			Stations (including SIG/COM/Railway Electric house)	
0	7	-	0	1	Earthworks	Level 6 Suggest to be aligned to the further breakdown in BOQ
0	7	-	0	2	Subbase and Base Course	
0	7	-	0	3	Surface Course	
0	7	-	0	4	Building Works	
0	7	-	0	5	Mechanical Works	
0	7	-	0	6	Miscellaneous Works	
0	7	-	0	7	Building MEPs	
0	7	-	0	8	Exterior Works / Related Facilities	
0	8	-			Depots	
0	8	-	0	1	Major Buildings (OCC, WS & LRS)	Level 6 Suggest to be aligned to each building in BOQ
0	8	-	0	2	Small Buildings	Level 7
0	8	-	0	3	Training Center	Suggest to be aligned to the further breakdown in BOQ
0	8	-	0	4	Landscape	
0	9	-			Drainage System & River Bank Protection	
0	9	-	0	1	Earthworks	
0	9	-	0	2	Structural Works	
0	9	-	0	3	Drainage Works	
0	9	-	0	4	River Bank Protection Works	
0	9	-	0	5	SAPANG BALEN River Plan (N-03)	
0	9	-	0	6	Pump System for Underground and Gil Puyat Underpass (N-04)	
0	9	-	0	7	Drain System for Detention Basin 1 & 2 (N-05)	
1	0	-			Substations	
1	0	-	0	1	Earthworks	
1	0	-	0	2	Subbase and Base Course	
1	0	-	0	3	Building Works	
1	0	-	0	4	Mechanical Works	
1	0	-	0	5	Miscellaneous Works	

Table D - 8: DOTr Primavera Cloud – Schedule WBS Dictionary Page 6 of 7

C	P	L	L	N	N	Description	Remarks
1	0	-	0	6		Building MEPs	
1	0	-	0	7		Exterior Works / Related Facilities	
1	1	-				Trackwork	
1	1	-	0	1		Plain Line Track (Slab, ballast, etc)	
1	1	-	0	2		Switches & Crossing	
1	2	-				Railway Systems	
1	2	-	0	1		Signal and Train Control System	NS01, NS02, NS03 are based on Payment Milestones (very high level in BOQ. to be subdivided by contractors)
1	2	-	0	2		Telecommunications System	
1	2	-	0	3		Power Supply System	
1	2	-	0	4		Power Distribution System	
1	2	-	0	5		Overhead Catenary System (Overhead Contact line)	
1	2	-	0	6		SCADA	
1	2	-	0	7		Operation Control Center (OCC) System	
1	2	-	0	8		Platform Screen Door System	
1	2	-	0	9		Automatic Fare Collection System	
1	2	-	1	0		Depot Equipments (Facility)	
1	2	-	1	1		Training Facilities	
1	2	-	1	2		Fire System	
1	2	-	1	3		Asset Protection System	
1	2	-	1	4		Maintenance Management Information System	
1	2	-	1	5		Building Management System	
1	3	-				Client Procured Materials	
1	3	-	0	1		Rail	
1	3	-	0	2		Ballast	
1	3	-	0	3		Sleepers	
1	3	-	0	4		Fasteners	
1	3	-	0	5		Switches & Crossings	
1	4	-				Rolling Stock & Maintenance Vehicles	
1	4	-	0	1		Passenger Trainsets - Commuter	
1	4	-	0	2		Passenger Trainsets - Limited Express	
1	4	-	0	3		Maintenance Vehicles	
1	4	-	0	4		Freight Trainsets	
1	5	-				T&C and Handover	
1	5	-	0	1		Testing & Commissioning (Static Test, Dynamic Tests, Integration Test, SODT)	
1	5	-	0	2		Training	
1	5	-	0	3		Final Documentation (as built drawing, manuals, etc)	
1	5	-	0	4		Spare Parts/Special Tools	

Table D - 9: DOTr Primavera Cloud – Schedule WBS Dictionary Page 7 of 7

C	P	L	L	N	N	Description	Remarks
1	6					Operation Readiness & Trial Run	
1	6	-	0	1		Early Phase (Policies, Plans, mobilization)	
1	6	-	0	2		O&M Management & Support Services (Management systms & tools, IT, procurement, D&B documentation, OHSSE, stakeholders management, PMO, etc)	
1	6	-	0	3		Deployment phase (Procedures and rule books, recruiting & training, fitout, etc)	
1	6	-	0	4		Trial Run & Certification	
1	7					Provisional Sum / Dayworks	

Table D - 10: Activity Codes Page 1 of 1

DOTr NSCR - P6 Activity Code

DOTr01 - Project Group

Code Value	Description
PW	Project Wide
N1	NSCR (Metro Manila to Malolos)
N2	MCRP (Malolos to Clark International Airport)
SC	NSRP - South (Metro Manila to Calamba)

DOTr02 - Sub-Phase

Code Value	Description
KD	Key Date
AD	Access Dates
KM	Key Milestones
IM	Interface Milestones
MB	Mobilization (Staff/Office/Camp/Facility)
PP	Management Plan and Procedures
MR	Meetings and Reporting
PM	Other Project Management
LA	Land Acquisition (RAP) related
SV	Survey & Study (data collection)
CD	Concept Design / System Design
PD	Preliminary Design / FEED
DD	Detail Design
FD	Final Design (Shop Drawings)
SW	Software Design & Development
IC	Interface Coordination Drawings
PR	Procurement
MF	Manufacturing & Fabrication (Including TT, FAI, FAT)
TD	Delivery to Site (Overseas & Domestic)
TE	Construction Temporary facilities
AW	Advance works / Enabling works
YN	Construction Installation
PI	Post Installation Check-out Test
ST	Static Test
DY	Dynamic Test
SI	System Integrated Test
TO	Trial Operation, Trial Running
CA	Certification & Authority Approval
TR	Training (including plans and manuals)
OM	O&M related (Operation Readiness)
HO	Handover - Documentation/Spare parts/Special tools
DM	Demobilization / Site Rehabilitation

DOTr03 - Responsibility

Code Value	Description
DOT	DOTr
NST	NSTren
ARP	Arup
GCR	GCR
CON	Contractors
PNR	PNR
NHA	NHA
SFH	SFHC

DOTr04 - Land Acquisition (Specific)

Code Value	Description
FSS	Feasibility Study Surveys
DDS	DED Surveys
LSV	Land and Structure Validation
NOT	Notice of Taking
APP	Appraisal
OTB	Offer to Buy
EXP	Expropriation
PYP	Payment Processing
TOT	Transfer of Title
PTE	Permit to Enter
TCU	DENR Tree Cutting
PCL	PROW Clearing (PAP's structures)
NA	Not Applicable

DOTr05 - Subsystem/SubGroup

Code Value	Description
001	Project/Contract Wide
002	Professional and Technical Services
003	Resettlement Action Plan related
004	AD-Demolition
005	AD-Utility Diversion (or Protection)
006	AD-Relocation of Existing Facilities
007	EW-Earthworks
008	EW-Maintenance Road/Access Road
009	EW-Existing Road Realignment
010	EW-Swampy Section
011	EW-Subbase and Base Course
012	EW-Surface Course
013	EW-Structural Works
014	EW-Miscellaneous Structures
015	EW-Plumbing and Sanitary Works
016	STR-Viaduct
017	STR-Bridges (Underbridge, Overbridge, etc)
018	STR-Underground Structures (Cut & Cover Tunnel, Bored Tunnel, Underpass etc)
019	STR-At Grade Structure
020	STR-Utility Corridor
021	STR-Box Culvert
022	STN-Earthworks
023	STN-Subbase and Base Course
024	STN-Surface Course
025	STN-Building Works
026	STN-Mechanical Works
027	STN-Miscellaneous Works
028	STN-Building MEPs
029	STN-Exterior Works / Related Facilities
030	DPT-Major Buildings (OCC, WS & LRS)
031	DPT-Small Buildings
032	DPT-Training Center
033	DPT-Landscape
034	DSRB-Earthworks
035	DSRB-Structural Works
036	DSRB-Drainage Works
037	DSRB-River Bank Protection Works
038	DSRB-SAPANG BALEN River Plan (N-03)
039	DSRB-Pump System for Underground and Gil Puyat Underpass (N-04)
040	DSRB-Drain System for Detention Basin 1 & 2 (N-05)
041	SST-Earthworks
042	SST-Subbase and Base Course
043	SST-Building Works
044	SST-Mechanical Works
045	SST-Miscellaneous Works
046	SST-Building MEPs
047	SST-Exterior Works / Related Facilities
048	TW-Plain Line Track (Slab, ballast, etc)
049	TW-Switches & Crossing
050	SYS-Signal and Train Control System
051	SYS-Telecommunications System
052	SYS-Power Supply System
053	SYS-Power Distribution System
054	SYS-Overhead Catenary System (Overhead Contact line)
055	SYS-SCADA
056	SYS-Operation Control Center (OCC) System
057	SYS-Platform Screen Door System
058	SYS-Automatic Fare Collection System
059	SYS-Depot Equipments (Facility)
060	SYS-Training Facilities
061	SYS-Fire System
062	SYS-Asset Protection System
063	SYS-Maintenance Management Information System
064	SYS-Building Management System
065	PRC-Rail

Code Value	Description
066	PRC-Ballast
067	PRC-Sleepers
068	PRC-Fasteners
069	PRC-Switches & Crossings
070	RS-Passenger Trainsets - Commuter
071	RS-Passenger Trainsets - Limited Express
072	RS-Maintenance Vehicles
073	RS-Freight Trainsets
074	HO-Testing & Commissioning (Static Test, Dynamic Tests, Integration Test, SODT)
075	HO-Training
076	HO-Final Documentation (as built drawing, manuals, etc)
077	HO-Spare Parts/Special Tools
078	OPR-Early Phase (Policies, Plans, mobilization)
079	OPR-O&M Management & Support Services (Management systems & tools, IT, procurement, D&B documentation, OHSS&E, stakeholders management, PMO, etc)
080	OPR-Deployment phase (Procedures and rule books, recruiting & training, fitout, etc)
081	OPR-Trial Run & Certification
082	Provisional (others)

DOTr06 - Sub-Location

Code Value	Description
PRM000	Project/Contract Wide
STN001	Station - Alaijating
STN002	Station - Angeles
STN003	Station - Apalit
STN004	Station - Balagtas
STN005	Station - Banlic
STN006	Station - Bicutan
STN007	Station - Binan
STN008	Station - Blumentritt
STN009	Station - Bocaue
STN010	Station - Bucal
STN011	Station - Buendia
STN012	Station - Cabuyao
STN013	Station - Calamba
STN014	Station - Caloocan
STN015	Station - Calumpit
STN016	Station - Clark
STN017	Station - Clark International Airport
STN018	Station - EDSA
STN019	Station - Espana
STN020	Station - FTI
STN021	Station - Guiguinto
STN022	Station - Mabalacat
STN023	Station - Malabon
STN024	Station - Malolos
STN025	Station - Malolos South
STN026	Station - Marilao
STN027	Station - Meycauayan
STN028	Station - Muntinlupa
STN029	Station - New Clark City 1
STN030	Station - New Clark City 2
STN031	Station - New Clark City 3
STN032	Station - Nichols
STN033	Station - Pacita
STN034	Station - Paco
STN035	Station - San Fernando
STN036	Station - San Pedro
STN037	Station - Santa Mesa
STN038	Station - Santa Rosa
STN039	Station - Santo Tomas
STN040	Station - Sindalan
STN041	Station - Solis

Code Value	Description
STN042	Station - Sucat
STN043	Station - Tabing Ilog
STN044	Station - Tuktukan
STN045	Station - Tulubán
STN046	Station - Valenzuela
STN047	Station - Valenzuela Polo
SSTN01	Substation - N1-01
SSTN02	Substation - N1-02
SSTN03	Substation - N1-03
SSTN04	Substation - N1-04
SSTN05	Substation - N1-05
SSTN06	Substation - N1-06
SSTN07	Substation - N1-07
SSTN08	Substation - N1-08
SSTN09	Substation - N1-09
SSTN10	Substation - N2-10
SSTN11	Substation - N2-11
SSTN12	Substation - N2-12
SSTN13	Substation - N2-13
SSTN14	Substation - N2-14
SSTN15	Substation - N2-15
SSTN16	Substation - N2-16
SSTN17	Substation - N2-17
SSTN18	Substation - N2-18
SSTN19	Substation - N2-19
SSTN20	Substation - N2-20
SSTN21	Substation - N2-21
SSTN22	Substation - N2-22
SSTS01	Substation - S-01
SSTS02	Substation - S-02
SSTS03	Substation - S-03
SSTS04	Substation - S-04
SSTS05	Substation - S-05
SSTS06	Substation - S-06
SSTS07	Substation - S-07
SSTS08	Substation - S-08
SSTS09	Substation - S-09
SSTS10	Substation - S-10
SSTS11	Substation - S-11
SSTS12	Substation - S-12
SSTS13	Substation - S-13
SSTS14	Substation - S-14
SSTS15	Substation - S-15
SSTS16	Substation - S-16
SSTS17	Substation - S-17
SSTS18	Substation - S-18
SSTD01	Substation - N1 Depot
SSTD02	Substation - N2 CIA Depot
SSTD03	Substation - SC Banlic Depot
DPT001	Depot - Calamba
DPT002	Depot - Clark
DPT003	Depot - Malanday, Valenzuela

Table D - 11: DOTr Primavera – Schedule Activity ID Numbering System Page 1 of 3

Activity ID : ACTIVITY ID NUMBERING SYSTEM

Following section is extracted from Planning and Schedule Manual
 All Project Schedules are developed by using Primavera P6 software. It defines each Design, Manufacturing, Installation and Testing activity for different sections and stages. It also establishes the sequence and logic between the activities. This section will explain the principles for Activity ID Numbering System.

In Primavera P6, it is allowed to have 20 digits for Activity ID. However, it is not easy to remember or recognize if the Activity ID is too long and complicate. Therefore, we consider using only 13 digits for Activity ID and group them into 4 blocks. The details of the 4 blocks coding structures will be explained as below:

Block 1	Block 2	Block 3	Block 4
OBS / Contract	PBS Code	ABS Code	ID Number
LLNN	LLL	LL	NNNN

Block 1 contains first to fourth digit of the Activity ID and they represent OBS Code (Contract Number). Excluding first 2 letters (CP) of contract number, it comprises rest two letters (LL) and two numbers (NN).

Block 1
OBS / Contract
LLNN

Contract Number	SUBP Description
N01	Building and Civil Engineering Works -17km of Viaduct and 2 elevated Stations
N02	Building and Civil Engineering Works - 16km of Viaduct and 1 elevated Stations
N03	Building and Civil Engineering Works - 16km of Viaduct and 2 elevated Stations
N04	Building and Civil Engineering Works - 6.5km of mainline and 1.1km depot access line, 1 U/G Stations
N05	Building and Civil Engineering Works - Depot (approx. 33ha)
S01	Building and Civil Engineering Works - 1.1 km of Viaduct and 1 Elevated Station
S02	Building and Civil Engineering Works - 7.9 km of Viaduct and 3 Elevated Station
S3a	Building and Civil Engineering Works - 4.5 km of Viaduct, Atgrade, 1 atgrade Station and 1 Elevated Station
S3b	Building and Civil Engineering Works - 10.7 km of Viaduct, Atgrade, 1 semi U/G, 1 atgrade, and 2 Elevated Stations
S04	Building and Civil Engineering Works - 8.5 km of Viaduct and 2 Elevated Station
S05	Building and Civil Engineering Works - 12.8 km of Viaduct and 3 Elevated Stations
S06	Building and Civil Engineering Works - 10.3 km of Viaduct and 3 Elevated Stations
S07	Building and Civil Engineering Works - Depot (Approx. 20ha)
NS01	E&M Systems and Track Works including PSD at all NSCR stations
NS02	Rolling Stock-Commuter Trainsets (38 trainsets consisting of 8 cars, total 304 cars)

Block 2 contains the fifth to seventh digit of the Activity ID and they represent Product Breakdown Structure code (PBS). In principle, it should align to client’s WBS Level 4. However, with discussion and approval from the Client/GCR, it could be further broken down and added with new items as per scope of work.

Block 2
PBS Code
LLL

Subgroup	Description
GEN	General and Consultancy Services
RAP	RAP (Resettlement Action Plan)
ADW	Advance & Enabling Works
EWS	Earthworks
STR	Railway Structures
STN	Stations (including SIG/COM/Railway Electric house)
DPT	Depots
DRB	Drainage System & River Bank Protection

Table D - 12: DOTr Primavera Cloud – Schedule Activity ID Numbering System Page 2 of 3

SST	Substations
TWK	Trackwork
SYS	Railway Systems
PRC	Client Procured Materials
RSV	Rolling Stock & Maintenance Vehicles
THO	T&C and Handover
OPR	Operation Readiness & Trial Run
PRS	Provisional Sum / Dayworks

Block 3 contains the eighth and ninth digit of the Activity ID and they represent Activity Breakdown Structure code (ABS). It consists of 2 letters (LL). Their details are listed below:

Block 3
ABS Code
LL

ABS	ABS Description
KD	Key Date
AD	Access Dates
KM	Key Milestones
IM	Interface Milestones
MB	Mobilization (Staff/Office/Camp/Facility)
PP	Management Plan and Procedures
MR	Meetings and Reporting
PM	Other Project Management
LA	Land Acquisition (RAP) related
SV	Survey & Study (data collection)
CD	Concept Design / System Design
PD	Preliminary Design / FEED
DD	Detail Design
FD	Final Design (Shop Drawings)
SW	Software Design & Development
IC	Interface Coordination Drawings
PR	Procurement
MF	Manufacturing & Fabrication (including TT, FAI, FAT)
TD	Delivery to Site (Overseas & Domestic)
TE	Construction Temporary facilities
AW	Advance works / Enabling works
YN	Construction Installation
PI	Post Installation Check-out Test
ST	Static Test
DY	Dynamic Test
SI	System Integrated Test
TO	Trial Operation, Trial Running
CA	Certification & Authority Approval
TR	Training (including plans and manuals)
OM	O&M related (Operation Readiness)
HO	Handover - Documentation/Spare parts/Special tools
DM	Demobilization / Site Rehabilitation

Block 4 contains the tenth to thirteenth digit of the Activity ID and they represent the ID number ranging from 0000 to 9999.

Table D - 13: DOTr Primavera Cloud – Schedule Activity ID Numbering System Page 3 of 3

<i>Block 4</i>	
<i>ID Number</i>	
<i>NNNN</i>	

ID No.	ID No. Description
0	ID No. 0000
⋮	⋮
9999	ID No. 9999

B) TECHNICAL REQUIREMENTS (ERT)

(This page is intentionally left blank)

1 System Requirements

1.1 Introduction

- 1.1.1 The purpose of this document is to define the minimum Technical Requirements (ERT) for the Commuter Rolling Stock. This ERT is supported by a General Requirements (ERG) and other tender documents. Should there be any discrepancy between the ERG and ERT, the contents of the ERT shall prevail.
- 1.1.2 The purpose of this document is to define the minimum Technical Requirements (ERT) for the NSCR-N2&SC. This ERT is supported by a General Requirements (ERG) and other tender documents. Should there be any discrepancy between the ERG and ERT, the ERT shall prevail.
- 1.1.3 This document includes the requirements as laid out in the Contract; these requirements shall be subjected to a formal verification and validation process supported by a requirements management database all of which will be supplied by the Contractor to include e.g. production, FAT, delivery, integrated testing and commissioning, acceptance including supply and delivery to Site of all related materials, spare parts, special tools, documentation, training, etc. to ensure satisfactory operation and maintenance of the new Rolling Stock fleet.
- 1.1.4 The scope of this document is to assist in the procurement of a new 38 x 8-cars Rolling Stock fleet. The following shall, without limitation, be included in the Works:
 - a. Provision of all documentation and support materials associated with the operation and maintenance of the cars as specified herein;
 - b. Technical support and defects notification coverage until the completion of the Defects Notification Period;
 - c. Interfacing with other systems and contractors, which includes but is not limited to on-board communications and signalling equipment, including design, provision of equipment, components and materials as specified in all interface requirements described within these ERG and ERT documents;
 - d. Training for maintenance staff, engineers and operators, including all necessary training materials, training kits, demonstration equipment and training venues;
 - e. Supply and installation of all consumables and materials required for testing and commissioning;
 - f. Provision of drawings, calculations and other documents as specified herein and/or as may be required;
 - g. Provision of design development items, studies and reports as specified herein;
 - h. Recommendation and supply of spares and consumables, special tools, special test equipment and special training as specified herein; and
 - i. Supply of any other equipment or any other service that may be required for completion of the Works.

1.2 Design Requirement

1.2.1 General

- 1.2.1.1 The requirements listed in this ERT are the minimum levels of design conformance and acceptable functionality. They are not intended to restrict innovation and flexibility within the design process, but set parameters for that process which shall not be contravened where emphasized.
- 1.2.1.2 The Contractor’s design process shall ensure that all systems, subsystems, assemblies and components of each consist are complementary and compatible in form and function. Other design requirements not specifically mentioned in this ERT but found and deemed necessary by the Contractor for the complete and efficient completion of the Project shall be presented/submitted to the Engineer for review.
- 1.2.1.3 The following general design concepts shall be incorporated to increase maintainability and maximize availability and at the same time meet efficient operational and environmental requirements.
- a. Use of interchangeable, modular components;
 - b. Use of service proven design;
 - c. Avoiding use of equipment that is deemed “black box”;
 - d. Use of extensive and prominent labelling of parts and wires;
 - e. Use of unique serial numbers for traceability of components;
 - f. Focus on low life cycle cost as much as possible;
 - g. Environment and human friendly;
 - h. Minimize human error (in usage);
 - i. Cost efficient (energy and labor); and
- 1.2.1.4 Handicapped people responsive as per the National Council on Disability Affairs - IRR of BP 344.

1.2.2 Previous Usage

- 1.2.2.1 Handicapped people responsive as per the National Council on Disability Affairs - IRR of BP 344.
- 1.2.2.2 Equipment, assemblies and sub-assemblies, components and materials shall have proven record of satisfactory use in other Rolling Stock applications and shall be demonstrated as satisfactory to the Engineer.
- 1.2.2.3 Where design improvements can be made to enhance equipment performance, these shall be carried out and demonstrated in compliance with ERG - Clause 8.

1.2.3 Codes, Standards and Requirements

- 1.2.3.1 Codes, standards and requirements specified in this ERT shall be interpreted as a requirement for compliance. Where any specified codes, standards and requirements are in conflict with each other or with this ERT, the more stringent requirement shall apply, unless otherwise reviewed by the Engineer.

1.2.4 Design and Manufacturing Tolerances

1.2.4.1 Where not specifically identified by statement or reference code, the Contractor shall establish design and manufacturing tolerances reflective of best industry practice and shall be reviewed by the Engineer.

1.2.5 Design Management and Control

1.2.5.1 The Contractor shall establish, maintain and document the procedures to control and verify the Rolling Stock consist, design and all of its equipment. The Contractor shall submit a Design Submission Program for review by the Engineer.

1.2.5.2 The Contractor shall establish and maintain a documented systematic, comprehensive and verifiable system integration process throughout the execution of the Works. These processes shall ensure that interfaces and interaction between cars, infrastructure, subsystems, software and operating and maintenance requirements have been identified and engineered to function together as a system.

1.2.6 Design Review

1.2.6.1 At appropriate stages in the design process, formal documented reviews of the design and related issues shall be planned and conducted, which shall be in line with the Design Submission Program;

1.2.6.2 The Contractor shall ensure that participation in design reviews includes representatives of all functions, disciplines and entities concerned with the equipment and the stage(s) being reviewed;

1.2.6.3 The Contractor shall at least 15 days prior to the date of each design review submit in-progress design documents of the elements to be addressed at the meeting to the Engineer and all concerned. The Engineer reserves the right to attend any and all design reviews;

1.2.6.4 The Contractor shall, within 15 days after the date of each design review, submit to the Engineer Design Review Minutes, detailing all issues raised during the review, their resolution or ongoing design status and due date for resolution. These will be reviewed by the Engineer;

1.2.6.5 The Engineer reserves the right to carry out design audits of the Contractor periodically throughout the Contract as may be deemed necessary for validation of the design; and

1.2.6.6 The Engineer’s response shall be made within 21 days of receipt of the submission. All of the Engineer’s comments shall be adequately addressed by the Contractor with an up-revised submission with fourteen (14) days from the issuance of the Engineer’s comments.

1.2.7 Special Responsibility of the Contractor

1.2.7.1 No examination, review and approval by the Engineer of the design, drawings, and documents submitted by the Contractor, with or without amendment, or any approval or comment or consent given by the Engineer for any equipment or part of the Works, shall absolve the Contractor from any of their obligations under the Contract or any liability arising out of the designs, drawings and documents or equipment or part of the Works.

1.2.8 Driver’s Cab and Saloon Mock-up

- 1.2.8.1 In order to evaluate the effectiveness of the driver’s cab and saloon layout and function as specified in Sub-Clause 5.3 and 5.15 of the ERT, the Contractor shall develop the interior design of a full size, fully equipped driver’s cab and saloon mock-up. The driver’s cab and saloon mock-up shall be fully equipped to show completely built interior condition. The entire design of the driver’s cab and saloon shall be reviewed by the Engineer. The mock-up shall be strong enough to accommodate persons inside without the damage or deformation. It shall be constructed on a substantial platform, to facilitate transportation and to prevent damage (cracking) and distortion of the hardware.
- 1.2.8.2 The Contractor shall make two leading car Mock-up whose length is 10m. These Mock-up shall be shown to Philippine people in several public spaces. The Contractor shall pay the transfer fee of these Mock-up from Japan to the above public space and some public space to another public space.
- 1.2.8.3 The contractor shall responsible for the arrangement and the cost of moving the mock up around the designated areas nominated by the Client for 12 times over 18 months period of times.

1.3 Basic Train Formation

1.3.1 Basic Car Configuration

- 1.3.1.1 The Rolling Stock shall consist of 8 cars. The schematic diagram of train configuration is shown in Appendix A.
- 1.3.1.2 Under emergency conditions and/or train recovery, one train must be capable of operating with another train coupled to it for hauling (pushing or pulling).
- 1.3.1.3 The mass (tare weight) of the 8-cars train-set shall be 270 tons or less. Weight balance, lower center of gravity, etc., shall be taken into consideration.

1.3.2 Power and Auxiliary Electric System Configuration

- 1.3.2.1 The motor car shall be powered with one (1) power conversion equipment driving four AC motors each for the propulsion and the trailer car shall be supplied with a primary inverter to serve the auxiliary loads.
- 1.3.2.2 The simplified block diagram explaining this is shown in Appendix A for reference.

1.3.3 Rolling Stock Gauge

- 1.3.3.1 The car body and installed equipment in static mode shall not exceed the Rolling Stock Gauge in the following conditions:
- a. On a level, tangent track, the Rolling Stock is in a stopped state with the car body and bogies center lines aligned with the track center line;
 - b. The load condition is between the empty condition and the crush load condition; and
 - c. The car body and bogies are not tilting due to passengers or loaded material.
- 1.3.3.2 The Rolling Stock Gauge is shown in Appendix B.

1.3.4 Car Physical Characteristics

- 1.3.4.1 The following physical characteristics indicate fundamental car dimensions that shall be given careful consideration:
- a. Car body Length: 19,500 mm (excluding coupler, overhung of leading car)

- b. Overall length: 20,000 mm (excluding overhung of leading car)
- c. Train length: 160,000 mm (excluding overhung of both leading cars)
- d. Overall Width: 2,950 mm (excluding light on both sides of the car)
- e. Overall height from top of rail to roof: 3,655 mm (excluding air conditioning system on the roof)
- f. Floor height: 1,130~1,150 mm
- g. Pantograph lock down height: Max. 4,150 mm
- h. Pantograph height working range: 4,400 – 5,415 mm
- i. Wheel Diameter: 780~860 mm
- j. Wheel base: 2,100 mm
- k. Distance between Bogie center: 13,800 mm
- l. Passenger Doors: pocket type
- m. Doorway width: 1,300 mm
- n. Doorway height: 1,850 mm.

1.3.4.2 Alternative car configurations and physical characteristics may be proposed and considered subject to verification of suitability of performance, capacity, network compatibility, infrastructure and facilities.

1.4 Track Standards

Main Line : EN 60 E1 Standard length 25 m.

Depot : JIS 50N Standard length 25 m.

1.5 Route Data

1.5.1 Horizontal Curve Radius

For main line: More than 260 m for NSCR, MCRP and NSRP-South

For side track: More than 100m

For stations: More than 400 m

For turnouts: More than 160 m (Main Line) for NSCR;
More than 165m (Main Line) for MCRP and NSRP-South

For depot: More than 100 m for NSCR;
More than 92 m for MCRP and NSRP-South

1.5.2 Transition Curve Length

For NSCR:

- a. Maximum out of L1, L2, and L3
- b. Where $L1=800 C$, $L2=7.5 CV$, $L3=6.75 CdV$
- c. Length between transition curves: more than 20 m

For MCRP and NSRP-South:

- a. Maximum out of L1, L2 and L3

- b. $L1=1000 Ca$ (over 120 km/h section),
- c. $L2= 7.5 CaV, L3=6.7 CdV$
- d. Length between transition curves: more than 20 m

1.5.3 Gradient

For NSCR:

- a. Main line
Standard: 25/1000
Absolute maximum: 35/1000
- b. Stations
Level (0)
Absolute maximum: 5/1000
- c. Turnouts and stabling track

Level (0)

For MCRP&NSRP-South :

- a. Main line
 - i. 25/1,000 (In the usual case or at the section with the operation speed of more than 120km/h)
 - ii. 35/1,000 (In the emergency or at the section with the operation speed of less than 120km/h)
- b. For Siding:
 - i. 25/1,000 (In the usual case)
 - ii. 35/1,000 (Unavoidable as well as at section not used for the passenger transportation, such as the branch line to the depot.)
- c. For Station and Depot: 0 (For special/provisional case 5/1,000)
- d. For Storage Track: 0 (In the usual case)
- e. The gradient only for turnout is not stipulated.
- f. That follows the location of the turnout in main line, siding, station or depot.

1.5.4 Vertical curve radius

For NSCR:

- a. 3000 m
- b. 4000 m (where curve radius less than 800 m)
- c. Vertical curve is required for more than 10/1000 of gradient change

For MCRP:

- a. 5,000 m (Section with the operation speed of more than 120km/h);
- b. 3,000 m (Section with the operation speed of under 120km/h,
- c. 4,000m apply to the radius of less than 800m)
- d. Vertical curve is required for more than 10/1,000 of gradient change

For NSRP-South:

- a. 3,000m (4,000m where curve radius is less than 600m)
- b. 2,000m (6,000m where curve radius is less than 600m) (absolute maximum)
- c. Vertical curve is required for more than 10/1,000 of gradient change

1.5.5 (Not Used)

1.5.6 Distance between Track Centers

More than 4.0 m (Main line), more than 4.0 m (Station), more than 4.0 m (Stabling track) (for NSCR, MCRP and NSRP-South).

1.5.7 Width of Structure Gauge

3.8 m

1.5.8 Station Platform

- a. Length: 180 m (220m in case of 10 cars in the future)
- b. Width: 8 m (standard)

1.5.9 Signaling system

European Train Control System (ETCS) Level 2 (900 MHz frequency for ETCS Level 2 to be confirmed) shall be adopted for the whole NSCR Project.

1.6 Environmental Conditions

1.6.1 The general environmental conditions in the Manila area are as follows:

- a. Ambient temperature: Min. + 15 °C - Max. +40 °C
- b. Relative humidity: Min. 60% - Max. 100%
- c. Maximum rainfall: 60 min. rating 120 mm/h
- d. 30 min. rating: 180 mm/h
- e. 10 min. rating: 270 mm/h
- f. Maximum wind velocity: 60 m/sec
- g. Maximum wind velocity at which train operations shall cease: 27.8 m/sec.

1.6.2 The Contractor is reminded that the alignment in Manila is near the sea coastline and runs through a relatively polluted air environment which may present a mildly corrosive atmosphere. Also, because of the generally long dry season, the air has high dust content.

1.6.3 The Contractor shall ensure that all equipment shall operate satisfactorily under the above conditions.

1.7 Weight Limits

1.7.1 General

- 1.7.1.1 The cars shall be designed on the following definitions of car loading with passenger weight taken as 65 kg per passenger.
- 1.7.1.2 A train consist of eight (8) cars shall have a passenger capacity of not less than 2,242 passengers (seating and standees). Maximum axle load shall not exceed 16,000 kg.
- a. W0 : tare weight
 - b. W1 : W0 + seated passengers
 - c. W2 : W1 + 4 passengers/m² standee
 - d. W3 : W1 + 7 passengers/m² standee
 - e. W4 : W3 + dynamic load and safety margin.
- 1.7.1.3 The structural design load (W3) is defined as the limit of static weight for the Rolling Stock structure before the introduction of dynamic effects and safety margin. Dynamic load and safety margin shall be added in accordance with JIS E 7106 or other equivalent standard.

1.7.2 Weight Penalties

- 1.7.2.1 The maximum weight of the 8-car trainset (tare weight) shall be 270 tons.
- 1.7.2.2 If the trainset is heavier than the indicated maximum weight, a penalty will be applied per train set as follows:
- a. A 0.1% of trainset price (as determined by the Engineer based on the Price Schedules) per every 100 kg above maximum weight, for each 8-car train set; and
 - b. If the mass of the trainset is more than 2,000 kg above the indicated maximum weight, the Contractor shall demonstrate the axle load of the Rolling Stock under all possible conditions such as crush load (20 t/car), in-balanced load and etc., will not exceed the 16 tons axle load limit, or else the Engineer has the right to refuse the acceptance of the cars, on behalf of the Employer.

1.7.3 Weight Control Program

- 1.7.3.1 The Contractor shall tabulate the weight of all major systems and all ancillary equipment for each car type, and shall provide this information to the Engineer on a monthly basis during the design and manufacturing phases of the Project.
- 1.7.3.2 Should the tabulations indicate that the mass of any piece of hardware shall exceed the predicted value; the Contractor shall immediately advise the Engineer of the steps to be taken to achieve the overall guaranteed weight. During the manufacturing phase, estimated weight shall be replaced in the tabulations by actual measured weights.
- 1.7.3.3 The Contractor shall also provide the Engineer with the locations of the center of gravity of the completed car bodies and completed bogies, plus the finished car.

1.8 Train Performance

1.8.1 General

- 1.8.1.1 For the purpose of calculating and submitting train performance figures, train configuration and weight shall be as defined in Sub-Clauses 1.3 and 1.7 Basic Train Formation and Weight Limits, respectively. Acceleration and braking requirements shall be met under 20t/car loading condition and with half-worn wheels.

1.8.2 Performance Values

- 1.8.2.1 The following train performance shall be achieved, under any conditions of wheel wear, except where noted:
- a. Maximum operation speed: 120 km/h
 - b. Acceleration: 3.3 km/h/s (0-30 kph – thereafter, the Bidder shall make their own calculation of traction force in order to comply with the basic requirements)
 - c. Jerk limit under all acceleration and service braking conditions (max.): 1.1 m/s³
 - d. Service brake deceleration: 4.2 km/h/s
 - e. Emergency brake deceleration: 4.7 km/h/s
 - f. Severity of service: Shall meet conditions of continuous 1 round trip of peak operation at loads of 20 t/car or higher, without adverse effect to any system
- 1.8.2.2 Acceleration and deceleration values must be maintained under all loading conditions. All braking requirements must be maintained under all loading conditions.
- 1.8.2.3 Jerk during acceleration and deceleration shall not be more than 1.1 m/s³ (except under emergency braking condition) and in any direction. Failure of the jerk limiting system shall not limit the braking effort. Indicated speed shall be within ± 2 km/h of actual speed at any speed.
- 1.8.2.4 In addition, the pneumatic system shall meet the following brake reaction times:
- a. Full service brake application : 1.5 seconds
 - b. Emergency brake application : Max 1.5 seconds
 - c. Full service brake release : 2.0 seconds
 - d. Emergency brake release : 3.0 seconds.
- 1.8.2.5 The brake reaction times of a and b are defined from the order of braking to 90% of brake cylinder pressure, and those of c and d are defined from full pressure to 10% of brake cylinder pressure.

1.8.3 Performance Characteristics

- 1.8.3.1 Performance curves for traction and braking shall be established on the basis of kN / metric ton versus speed for the W3 and 20 t/car loading condition.
- 1.8.3.2 The corresponding traction motor characteristics, and the train mass, shall be considered in the Design Performance Curve as defined in JIS E 6102 (which is consistent with IEC 60349) or other equivalent standard.

1.8.4 Degraded/Emergency Performance

- 1.8.4.1 The Contractor shall confirm by calculation and by test that an 8-car train with 20 t/car loading condition, with the propulsion system on one of the 4 motor car units totally inoperative is capable of completing a continuous trip.
- 1.8.4.2 The Contractor shall confirm by calculation and by test that an 8-car train with 20 t/car loading condition, with the propulsion system on two of the 4 motor car units totally inoperative is capable of operating to the next station, including traversing the maximum gradient of the main line. However, reduction of acceleration and restriction of regenerative braking force may be accompanied.

- 1.8.4.3 The Contractor shall confirm by calculation and by test that an 8-car train with W0 and 20 t/car loading condition is capable of hauling (pushing or pulling) another 8-car train with 20 t/car loading condition to the nearest station, including traversing the maximum main line gradient.
- 1.8.4.4 Similarly, the Contractor shall confirm by calculation and by test that 8-car train in W0 loading condition is capable of hauling (pushing or pulling) another 8-car train also in W0 loading condition, with an inoperative propulsion system, from the farthest terminal station back to the depot, including its worst condition.
- 1.8.4.5 The Contractor shall confirm by calculation and test that 8 cars train-set at W0 loading condition can push and tow a 10 cars train-set at 20 t/car loading condition (537 ton) with an inoperative propulsion system in its worst condition. If the healthy train cannot be pushed or towed at the 3.5% upgrade, then the high acceleration mode shall be applied. But this requirement is under the non-slip condition, and the adhesion at this requirement is not to be considered. The test shall be conducted under the non-slip condition.
- 1.8.4.6 For the test at 20 t/car written above, it is also permitted to convert from the results of empty tests and certain loaded tests.
- 1.8.4.7 In case of coupling inoperable train and rescue train, emergency brake circuit shall be connected between these two trains by emergency electric coupler. These two trains emergency brake shall be controlled at the same demand synchronously from both train’s operator cabs. Intercom between these trains, buzzer and any other circuit required for rescue operation shall be connected by emergency electric coupler. The specifications for rescue operation and emergency electric coupler shall be considered coupling other project trains in interoperability section and shall be reviewed by the Engineer.

1.8.5 Brake Performance at Parking

- 1.8.5.1 The Contractor shall confirm by calculation and by test that the friction brakes are capable of holding 8-cars train with 20 t/car loading condition on a 3.5% grade. Also, the Contractor shall confirm by calculation and by test that the parking brake is capable of holding an 8-cars train coupled to a disabled (i.e. without any brake) 8-car train with both trains at W0 load condition on a 3.5% grade.
- 1.8.5.2 The parking brake force on an individual axle shall allow wheels to rotate during emergency train recovery (pushing/pulling of defective trainset).

1.8.6 Performance Calculation

- 1.8.6.1 The Contractor shall calculate train performance by simulation. A running curve with speed versus distance for both directions shall be provided as a simulation result.
- 1.8.6.2 Rotating mass shall be calculated by the shape of the wheel, brake disc, rotor of motor etc. for the performance calculation.

1.8.7 Energy Consumption

- 1.8.7.1 The Contractor shall design the train to minimize energy consumption and calculate energy consumption of the train running on the entire revenue line for both directions at a loading conditions of W0 and W0 plus a load of 20 t/car.

1.9 Noise, Vibration and Aerodynamics

1.9.1 Noise Requirements

1.9.1.1 The Rolling Stock shall be designed and tested to meet the following noise levels:

- a. The interior noise level at any point in any car (including the Driver’s Cab), 1.6 m above floor level, while stationary on an open section of track, but with all auxiliary systems running, shall endeavor not to exceed 69 dB(A) Lmax;
- b. The exterior noise level of any car, measured 7.5 m from the center and 1.5 m above rail level, while stationary on an open section of track with all auxiliary systems running, shall endeavor not to exceed 73 dB(A) Lmax;
- c. The interior noise level at any point in any car (including the Driver’s Cab) 1.6 m above floor level, with the train running at 0 to 60 km/h on an open section of track, with all auxiliary systems running, shall endeavor not to exceed 74 dB(A) Lmax. Compliance to this requirement to be validated at the Contractor’s proposed facility;
- d. The exterior noise level of any car, measured 7.5 m from the center and 1.5 m above rail level, with the train running at 0 to 60 km/h on an open section of track with all auxiliary systems running, shall endeavor not exceed 83 dB(A) Lmax. Compliance to this requirement to be validated at the Contractor’s proposed facility; and
- e. Door operation noise produced by simultaneous operation of all saloon doors on one side of the car shall endeavor not to exceed 72 dB(A) Lmax during the sliding operation and 78 dB(A) Lmax for the locking/unlocking.

1.9.1.2 The tests shall be conducted according to JIS E 4021 or equivalent standards for the internal noise.

1.9.1.3 The tests shall be conducted according to JIS E 4025 or equivalent standards for the external noise.

1.9.1.4 Measurement of running train noise, both for the interior and the exterior case, shall be conducted on MCRP and NSRP-South mainline track or at the Contractor’s proposed facility where rail roughness is compliant with JIS E 4021/4025 or equivalent standards.

1.9.2 Vibration Requirements

1.9.2.1 All equipment, sub-assemblies and components shall be capable of withstanding shock and vibration of the Rolling Stock satisfactorily such that they do not fail prematurely within their designed life. These shall comply with JIS E 4031 or equivalent standards.

1.9.2.2 With the train at stationary and with all auxiliary equipment operating at rated capacity, no portion of the interior of the cars shall exceed the following levels of vibration:

- a. 2.5 mm peak-to-peak amplitude for frequencies less than 1.4 Hz;
- b. 0.01 g peak acceleration for the frequency range 1.4 Hz to 20 Hz; and
- c. 0.75 mm/second peak velocity for the frequency range above 20 Hz.

1.9.3 Noise and Vibration Control

1.9.3.1 Rotating or reciprocating equipment and inductive electrical equipment (such as transformers, inductors, etc.) mounted to the rail car body, which may become a source of vibration, and any equipment (bogie or car body mounted) which may become a source of noise and vibration shall be adequately provided with resilient suspension and acoustically attenuated respectively.

- 1.9.3.2 The resonant frequency of the resilient suspension system shall be designed to avoid coupling with that of the car structure. All suspensions shall be designed to provide maximum isolation for all modes of vibration. Also, resilient mounts shall be arranged in a manner such that the equipment shall be retained safely on the car, and may continue operation, under all operating conditions stated in this ERT and any other applicable specification, in the event of a complete failure of the elastomeric material.
- 1.9.3.3 It shall be the responsibility of the Contractor to take all necessary precautions to minimize noise radiation and transmission by using up-to-date design techniques and proper acoustic attenuation materials, where required. The Contractor shall provide for review by the Engineer all pertinent details of the acoustic attenuation and any special noise reduction techniques used.

1.9.4 Aerodynamics and Pressure Effects

- 1.9.4.1 The modular design and construction shall ensure that passengers and/or the driver do not experience significant discomfort due to internal pressure changes when operating over the designated route, induced by infrastructure and passing trains and effects on passengers on platforms and on trackside workers.

1.10 Ride Quality

- 1.10.1.1 The car shall be designed to be free from objectionable vibration and shock. All mounted equipment shall be free from resonance to avoid undue audible and visual distraction.
- 1.10.1.2 The ride quality shall be evaluated according to JIS E 4023 or equivalent standards. The Contractor shall provide a vibration analysis for the Engineer’s review, which shall demonstrate compliance to these ride quality requirements.

1.11 Maintainability Requirements

- 1.11.1 In addition to the requirements specified elsewhere herein, the cars shall be designed to meet the following criteria:
- a. On the premise that various maintenance shown in the following is to be carried out, other special maintenance work shall not be required;

Table 1.1 Basic Rolling Stock Maintenance Categories for MCRP&NSRP-South

Category		Period	Maintenance Content
Departure Inspection		Before departure	Check in-service monitoring, visual check of major parts of cars.
Light Maintenance	Weekly Inspection	Within 6 days	Check status of bogies, wheels, pantograph, doors and other items while cars are connected. Replace consumables for brakes, pantographs and other items.
	Monthly Inspection	Within 3 months (90 days)	Confirm the status of cars and their functions while cars are connected. Replace consumables, measure voltage of auxiliary circuits, control circuit and other circuits, inspect functioning of main circuit, etc.

Category		Period	Maintenance Content
Heavy Maintenance	Semi overhaul	Within 4 years or Within 600,000 km	Remove bogies, wheels, wheel axles, brakes, main motors and other major parts, perform detailed inspection and replace parts
	Overhaul	Within 8 years or Within 1,200,000 km	Disassemble almost all parts, perform detailed inspection of devices. Paint car body.
	General overhaul (Renewal)	Every 10 to 15 years	General overhaul shall carry out replacement of the major electronic parts with new ones. If necessary, the interior is renewed.
Other Maintenance	Unscheduled Repair	Whenever necessary	Replace broken-down parts. (bogies, pantograph, air conditioner, etc.).
	Wheel re-profiling	150,000 km	Use wheel profiler to correct wheel shape and maintain ride comfort level.

- b. All units or sub-assemblies requiring replacement or off-train adjustment shall be arranged for easy unit exchange;
- c. Equipment and systems shall be accessible for inspection, maintenance and repair with minimum strain to people involved and within the limitation of the existing and new maintenance facilities, including the light maintenance area;
- d. The Contractor shall submit a detailed work process chart illustrating how the maintenance requirement can be achieved. The work process shall indicate work tasks, labor and material/component requirements, supplemented by a critical path analysis. The complete work process shall be subjected to a maintenance demonstration to confirm the validity of the work process model; and
- e. For purposes of defining the maintenance requirement of each consist, the yearly-accumulated kilometer run assumption shall be 250,000 km.

1.12 General Electrical Requirements

1.12.1 Electro-Magnetic Compatibility (EMC)

- 1.12.1.1 Conducted and radiated Electro-Magnetic Interference/Radio Frequency Interference (EMI/RFI) shall be held to a minimum commensurate with good design practices, and in no case shall signal levels be permitted to interfere with, or compromise, the operation of on-board signaling equipment, on-board intercom equipment or ultra-high frequency radio equipment. EMI/RFI or any other form of interference shall not affect the proper and safe operation of the NSCR and MCRP&NSRP-South railway and any other local facilities.
- 1.12.1.2 Electrostatic and magnetic electrical shielding methods shall be employed to minimize the effect of stray signals and transient voltages on low level interconnecting cables.
- 1.12.1.3 Components and functional circuits shall be grouped according to their similar sensitivities to electrical interference and power supply needs, and grouped to reduce the effects of voltage drops in the ground circuits, power and return leads, and shall be routed in a raceway or harness.
- 1.12.1.4 The Contractor shall submit an EMC control plan in accordance to IEC 62236 or equivalent to the Engineer for review. The plan shall include measures to reduce conducted, induced and radiated emissions to acceptable levels as specified in IEC 61000 series or equivalent.
- 1.12.1.5 The Contractor shall carry out measurement of the ensuing electro-magnetic environment to validate compliance to the above requirements.

1.12.2 Low-Voltage DC Control Power

- 1.12.2.1 The nominal system voltage shall be 1500 V dc. Unless otherwise specified, rated performance shall be provided at nominal voltage, and all equipment connected to the low voltage power supply shall not be damaged by continuous operation within the specified minimum and maximum voltage range.
- 1.12.2.2 In addition, continuous voltages at the upper threshold shall not damage any equipment. Variation of voltage outside the limits specified in Sub-Clause 1.12.3 Operating Voltage Range shall result to system shutdown without damage.

1.12.3 Operating Voltage Range

- 1.12.3.1 Unless otherwise specified, equipment connected to the low-voltage power supply shall operate over a power supply (line) voltage range from $0.7 \times (V_{nom})$ to $1.30 \times (V_{nom})$.
- 1.12.3.2 Peak-to-peak ripple voltage from a static power supply shall not exceed three percent of the nominal specified power supply output voltage, unless otherwise allowed.
- 1.12.3.3 It is recognized that if a transformer-rectifier unit is used to generate the low voltage DC, the ripple voltage shall be substantially greater than the three percent (3%) limit. In this case, the allowable ripple voltage shall be reviewed with the Engineer.

1.12.4 Transient Voltage Requirements

- 1.12.4.1 Equipment connected to the low voltage power system shall be capable of withstanding non-repetitive, transient, peak voltages by complying with IEC 62236-3-2 or equivalent.
- 1.12.4.2 Low-voltage power supplied equipment shall not be damaged by under voltage of any magnitude or duration. Recovery of connected equipment from the under-voltage condition shall be automatic or by train line reset. Train line and battery supplied relays shall not drop out for under voltages as low as $0.5 \times (V_{nom})$, with a duration of up to 50 μ s.

1.12.5 Reverse Voltage

- 1.12.5.1 Equipment, which may be powered from the battery bus, shall not be damaged by reverse polarity voltage of the same magnitude and duration as the specified positive voltage conditions.

1.12.6 Transients Generated by Equipment

- 1.12.6.1 Equipment connected to the low voltage power supply, including battery and train lines, shall not generate transient voltages in excess of +200 Vpk, with an energy content not to exceed 0.3 joules.
- 1.12.6.2 The equipment shall be designed such that the rate of change in voltage in any transient conducted from the equipment to the electrical interface shall not exceed 10 kV for up to 1 ms.

1.12.7 Overhead Line Supply System

- 1.12.7.1 Within 28 days of contract award the contractor shall provide pantograph and train characteristics to the NS-01 contractor to enable the computer simulation for the overhead line system / pantograph interface to be undertaken.
- 1.12.7.2 At a minimum, equipment powered directly from the overhead line power network shall withstand transient voltages with a peak of not less than five times the maximum continuous voltage rating of the overhead line supply. The rise time from 10 to 90 percent of the peak voltage shall be assumed at 1 ms and the fall time from 90 to 50 percent shall be 40 ms. The energy content shall not be less than 1000 joules.

1.13 Installation and Maintenance Requirements of Electric Works

1.13.1 Printed Circuit Boards

- 1.13.1.1 All electronic printed circuit boards shall be of the plug-in type unless subject to review by the Engineer.
- 1.13.1.2 The type of connector and contact material shall be reviewed by the Engineer.
- 1.13.1.3 The board material shall be suitable to rail application and the number of layers in a multi-layer board may exceed the currently specified limit of six.
- 1.13.1.4 Components shall not be installed using sockets unless subject to review by the Engineer.
- 1.13.1.5 Use of surface mounted devices shall be reviewed by the Engineer.
- 1.13.1.6 Semiconductor operating temperature rating shall meet or exceed +85 °C.
- 1.13.1.7 Printed Circuit Boards shall be mechanically retained to prevent loosening in service. Circuit boards shall not be hard wired to the equipment, and shall be mechanically keyed to prevent insertion into the wrong rack location. Printed Circuit Boards shall be conformal coated, unless otherwise subjected to review by the Engineer.

1.13.2 Equipment Accessibility

- 1.13.2.1 All gauges, adjustment points, switches, etc., shall be easily accessible and clearly identified with permanent identification markings.

1.13.3 Device Reference Designators

- 1.13.3.1 All electrical devices on panels shall be identified with their alphanumeric designation corresponding to that used on the schematic diagrams.

1.13.4 Grounding

- 1.13.4.1 Safety grounding points shall be provided on all electrical equipment, unless otherwise subject to review by the Engineer. Grounding points shall be of tinned copper, clean, free from paint, and of a sufficient area to ensure proper electrical contact for the grounding cable fasteners. Un-tinned bronze grounding points and austenitic grade stainless steel grounding points are also considered acceptable. The area of any weld joining the grounding pad to a surface shall be at least equal to the cross-sectional area of the grounding cable.
- 1.13.4.2 Grounding points shall have either a tapped hole or, preferably, a clearance hole (with access to both sides) suitably sized for the lug attachment fasteners.
- 1.13.4.3 Minimum grounding cable size shall be 6 mm², unless otherwise reviewed by the Engineer, and the size shall be equal to, or larger than, that of the largest power wire connected to that equipment. All grounding wires and cables shall utilize longitudinally striped green and yellow insulation, or heat shrinkable tubing applied over the conductor insulation.

1.13.5 Electrical Interface

- 1.13.5.1 All cable connectors used in exterior locations shall be rated IP65 using quick connect/disconnect couplings with positive locking and visual indication of mating. These shall be subject to review by the Engineer.
- 1.13.5.2 Terminal blocks, where used, shall be of a high quality, plated stud type wherever possible, with proper creepage and clearance provisions for the voltage used. Terminal blocks shall each be given a unique identification number, and each "point" on the block shall be numbered.
- 1.13.5.3 The current capacity rating of all wiring interface connectors and terminal blocks, shall have de-rating compensation in accordance with applicable standards for expected high ambient temperature.

1.13.6 Wire Identification

- 1.13.6.1 All equipment wires shall be marked with a unique wire identification number by means of marker sleeves located within 50 mm of each end of each wire.
- 1.13.6.2 The identification numbering system shall correspond to the wire identification numbering system used on the schematic drawings and wiring diagrams.
- 1.13.6.3 The wire markings shall include the corresponding terminal block number where it is connected, placed distinctly at the far end of each wire marking.

1.13.7 Connectors

- 1.13.7.1 A single family of connectors shall be used for similar connections and functions within the Rolling Stock consist. A separate family of connectors may be used for power connections and control connections. The number of different connectors in the family shall be minimized.
- 1.13.7.2 All connectors shall have sufficient current ratings, with applied de-rating factors for expected operating temperatures of not less than 40 °C.

1.13.8 **Suppression**

- 1.13.8.1 All relay coils, contactor coils, solenoid valve coils and other inductive devices shall be furnished with coil suppression.
- 1.13.8.2 Contact suppression shall be provided where necessary or specified.

1.13.9 **Wire and Cable Installation**

- 1.13.9.1 Electrical wires and cables shall be run in cleats, conduit, ducts or wire trays, as the application permits, but all shall be protected from physical damage, such as chafing, ballast impact, etc. Wires and cables feeding equipment subject to the elements shall incorporate drip loops to prevent moisture from collecting around fittings.
- 1.13.9.2 The Contractor’s attention is drawn to the requirements of Sub-Clause 21.4.8 Voltage Segregation.
- 1.13.9.3 All wires and cables shall have sufficient current ratings, with applied de-rating factors for expected operating temperature of not less than 40 °C.
- 1.13.9.4 All wires and cable shall have sufficient spares; the wires and cable installation and number of spare wires and cables shall be subject to review by the Engineer.

1.14 Fail Safe Design

- 1.14.1 All equipment and systems affecting train safety and the safety of train crew and passengers, and/or identified as being “vital”, “safe”, or “fail safe”, shall be designed according to the following principles: couplers, door systems, on-board signaling systems, communication systems, wheel spin/slide systems, emergency brakes and propulsion power shut off systems shall be included as a minimum.
- 1.14.2 Only components having a high reliability and predictable failure modes and that have operated in similar service conditions to those in Manila service condition shall be used;
- 1.14.3 Components must be utilized in such a manner that ensures that a restrictive, rather than a permissive condition shall result from a component failure; for example, brakes shall apply, rather than release; train shall decelerate, rather than accelerate, etc.;
- 1.14.4 Circuits shall be designed such that when a normally energized electric circuit is interrupted or de-energized, it shall cause the controlled function to assume its most restrictive condition; broken wires, damaged or dirty contacts, a relay failing to respond when energized, etc., shall not result in an unsafe condition.
- 1.14.5 Component or system failures shall cause the train to stop or to run at a more restrictive speed than that permitted with no failure;
- 1.14.6 System safety equipment design must be such that any single independent component or subsystem failure results in a restrictive condition. Failures that are not independent, i.e. those failures, which, in turn always cause others must be considered in combination as a single failure and must not cause a permissive condition;
- 1.14.7 Any component or wire becoming grounded, or any combination of such grounds, shall not cause a permissive condition. Safety circuits shall be kept free of any combination of grounds that shall permit a flow of current equal to, or greater than, 75% of the release value of any device in the circuit.
- 1.14.8 Alternatively, redundancy shall be considered, which shall include not less than two entirely independent, parallel channels to perform each function. If only two channels are provided, a permissive decision shall be required from both for the system not to enter a more restrictive mode of operation. If more than two channels are provided, a more permissive decision shall be required from the majority for the system not to enter a more restrictive mode of operation.
- 1.14.9 During the design review process, the Contractor shall submit analyses for review by the Engineer, which demonstrate compliance with these safety principles.
- 1.14.10 These analyses shall address the following issues:
 - a. Circuit design;
 - b. Hardware design (including failure modes, effect and criticality analysis);
 - c. Electrical interference;
 - d. Software errors;
 - e. Short circuit analysis (ground, other conductors, etc.);
 - f. Open circuits; and
 - g. System failures.

1.15 Standards

1.15.1 The following are the summary of standards referred to in the Employer’s Requirements. The summary is not intended to be all inclusive.

Table 1.2 JIS Standards

No.	Year	Title	Equivalent	English Ver.
JIS A 1454	2010	Test methods-Resilient floor coverings		
JIS E 3313	1999	Illuminance - Headlight		
JIS E 4001	1999	Railway Rolling Stock-vocabulary	MOD IEC 60617:1991	
JIS E 4010	1985	Symbols for railway Rolling Stock and railway Rolling Stock parts		
JIS E 4011	1989	Measuring methods for mass of railway Rolling Stock		
JIS E 4014	2007	Test methods for insulation resistance and withstand voltage of railway Rolling Stock		
JIS E 4015	1989	Measuring methods for air conditioning and heating temperature of railway Rolling Stock		
JIS E 4016	1992	Illuminance for railway Rolling Stock-recommended levels and measuring methods		
JIS E 4017	2000	Railway rolling stock – Graphical symbols for electrical apparatus	MOC IEC 60617 MOD IEC 60027	
JIS E 4018	1995	Railway rolling stock – Measuring methods of leakage magnetic field		
JIS E 4021	2008	Railway rolling stock – Test methods inside noise		
JIS E 4023	1990	Vibration characteristics of railway rolling stock – measuring methods		E4023:90
JIS E 4024	1994	Railway rolling stock – Test methods of ventilation		
JIS E 4025	2009	Noise of outside railway rolling stock – Test methods	MOD ISO/DIS3095 :2005	
JIS E 4031	2013	Railway rolling stock parts – Test methods for vibration	MOD IEC 61373:1999	

No.	Year	Title	Equivalent	English Ver.
JIS E 4034	2011	Railway rolling stock parts – Test methods of resistivity for moisture and rainfall		
JIS E 4035	1995	Railway Rolling Stock -- High and low temperature test methods of parts		
JIS E 4036	1998	Railway Rolling Stock components -- General rules for dust tests		
JIS E 4037	2001	Railway Rolling Stock -- Components -- Test methods of weather ability		
JIS E 4041	2009	General rules for the test methods of electric rail car on completion of construction	MOD IEC 61133:2006	
JIS E 4047	2008	Rolling Stock-Body frame-Design methods for welded joints		
JIS E 4048	2008	Railway Rolling Stock -- Spot welded joints of mild steel -- Design methods		
JIS E 4051	2001	Railway Rolling Stock -- Dimension of car body and bogie -- Measuring methods		
JIS E 4111	2006	Clevis pins with head for railway Rolling Stock		
JIS E 4115	2006	Magnet valves for railway Rolling Stock		
JIS E 4118	2004	Bourdon tube pressure gauges for railway Rolling Stock		
JIS E 4205	2001	Oil damper for railway Rolling Stock -- General rules for performance		
JIS E 4206	1989	Spring rigging for railway Rolling Stock		
JIS E 4207	2004	Truck frames for railway Rolling Stock -- General rules for design		
JIS E 4208	2004	Test methods of static load for truck frames and truck bolsters of railway Rolling Stock		
JIS E 4309	2001	Composition brake shoes for railway Rolling Stock -- Quality requirements		
JIS E 4311	1999	Railway Rolling Stock -- Brake parts --		

No.	Year	Title	Equivalent	English Ver.
		General requirement for tests		
JIS E 4501	1995	Railway Rolling Stock -- Design methods for strength of axles		
JIS E 4502-1	2001	Axles for railway Rolling Stock -- Quality requirements	MOD ISO 1005-3:1982	
JIS E 4502-2	2001	Axles for railway Rolling Stock -- Dimensional requirement	MOD ISO 1005-9:1986	
JIS E 4504	2004	Wheel sets for railway Rolling Stock -- Quality requirements	MOD ISO 1005-7:1982	
JIS E 4603	2009	Electric speedometer equipment for railway Rolling Stock		
JIS E 4710	1995	Railway Rolling Stock - - Rubber vibration isolators -- General requirement		
JIS E 5002	1991	Air compressors for railway Rolling Stock -- Test methods		
JIS E 5003	2004	Test methods for direct current surge arresters of railway Rolling Stock		
JIS E 5004-1	2006	Control equipment for electric Rolling Stock – General service conditions and general rules	MOD IEC 60077-1:1999	
JIS E 5004-2	2006	Control equipment for electric Rolling Stock – Electro-technical components General rules	MOD IEC 60077-2:1999	
JIS E 5004-3	2008	Control equipment for electric Rolling Stock – Electro-technical components Rules for DC circuit breakers	MOD IEC 60077-3:2001	
JIS E 5004-4	2008	Control equipment for electric Rolling Stock – Electro-technical components Rules for AC circuit breakers	MOD IEC 60077-4:2003	
JIS E 5004-5	2007	Control equipment for electric Rolling Stock – Electro-technical components	MOD IEC 60077-	

No.	Year	Title	Equivalent	English Ver.
		Rules for HV fuses	5:2003	
JIS E 5008	2009	Power converters installed on board Rolling Stock -- Characteristics and test methods	MOD IEC 61287- 1:2005	
JIS E 5009	2009	Railway Rolling Stock-traction reactors -- Test methods	MOD IEC 60310:1991	
JIS E 5011-1	2009	Rolling Stock – Combined testing of power converter with ac motors Part1: Inverter system	MOD IEC 61377- 1:2006	
JIS E 5011-2	2009	Rolling Stock – Combined testing of power converter with ac motors Part2: Converter-Inverter system with intermediate DC link	MOD IEC 61377- 3:2002	
JIS E 5401-1	1998	Carbon steel tires for railway Rolling Stock -- Quality requirements	MOD ISO 1005- 1:1994	E5401-:98
JIS E 5401-2	1998	Carbon steel tires for railway Rolling Stock -- Wheel centers and tired wheels -- Dimensional, balancing and assembly requirements	MOD ISO 1005- 2:1986	E5401-:98
JIS E 6003	1985	General rules for design of driving cabs of electric commuter cars		
JIS E 6004	1992	Electric Rolling Stock -- General rules for performance tests		
JIS E 6005	1995	Railway Rolling Stock -- Automatic train control and automatic train stop device on board -- Test methods		
JIS E 6006	2001	Automatic train operating device for railway Rolling Stock -- Test methods		
JIS E 6102	2004	Railway Rolling Stock -- AC traction motors -- Test methods	MOD IEC 60349- 2:2002	
JIS E 6202	1993	Electromagnetic relays for railway Rollin g Stock -- General requirement		

No.	Year	Title	Equivalent	English Ver.
JIS E 6302	2004	Railway Rolling Stock -- Pantographs -- Test methods	MOD IEC 60494:2002	
JIS E 6401	2004	Power Resistors for Rolling Stock	MOD IEC 60322:2001	
JIS E 6402	1999	Railway Rolling Stock -- Static auxiliary power supply -- Test methods		
JIS E 6601	1999	Railway Rolling Stock -- Auxiliary rotating electrical -- Test methods	MOD IEC 60349:1991	
JIS E 6602	2004	Cooling unit apparatus for electric cars		
JIS E 7103	2006	Electric railcars for commuter use -- General requirement for design of bodies		
JIS E 7104	2002	Seats for passengers of railway Rolling Stock		
JIS E 7105	2006	Test methods for static load of body structures of railway Rolling Stock		E7105:89
JIS E 7106	2006	Rolling Stock – General requirement of car body structures for passenger car		
JIS K 1454	2010	Test methods-Resilient floor coverings		
JIS K 6251	2010	Rubber, vulcanized or thermoplastics- Determination of tensile stress-strain properties		
JIS Q 9001	2008	Quality Management Systems Requirement		
JIS R 3213	1998 2008	Safety Glass for Railway Rolling Stock Amendment 1		
JIS R 3212	1998 2008	Test Method for Safety Glazing Materials Amendment 1		
JIS Z 8502		Ergonomics Principles		

Table 1.3 ISO Standards

International Organization for Standardization (ISO)	
1	ISO 2631 – Evaluation of Human Exposure to Whole-body Vibration
2	ISO 6385 - Ergonomics principles in the design of work systems

3	ISO 9241 – Ergonomics for Human-Systems Interaction
4	ISO 10075 –Ergonomics Principles on Mental Work load
5	ISO 9000 – Quality Management and Quality Assurance Standards
6	ISO 9355 - Ergonomic Requirements

Table 1.4 EN Standards

European Norm (EN)	
1	EN 15227 – Railway applications. Crash worthiness requirements for railway carriages

Table 1.5 IEC Standards

International Electro-technical Commission (IEC)	
1	IEC 60349 – Electric Traction – Rotating Electrical Machines for Rail and Road Vehicles
2	IEC 61133 – Railway Applications / Rolling Stock – Testing of rolling stock on completion of construction and before entry into service.
3	IEC61375-1 - Electronic railway equipment - Train communication network (TCN) – Part 1: General architecture
4	IEC61375-2-1 - Electronic railway equipment - Train communication network (TCN) – Part 2-1: Wire Train Bus (WTB)
5	IEC61375-2-2 - Electronic railway equipment - Train communication network (TCN) – Part 2-2: Wire Train Bus conformance testing
6	IEC61375-2-3 - Corrigendum 1 - Electronic railway equipment – Train communication network (TCN) - Part 2-3: TCN communication profile
7	IEC61375-2-4 - Electronic railway equipment - Train communication network (TCN) – Part 2-4: TCN application profile
8	IEC61375-2-5 - Electronic railway equipment - Train communication network (TCN) – Part 2-5: Ethernet train backbone
9	IEC61375-3-1 - Electronic railway equipment - Train communication network (TCN) – Part 3-1: Multifunction Vehicle Bus (MVB)
10	IEC61375-3-2 - Electronic railway equipment - Train communication network (TCN) – Part 3-2: MVB (Multifunction Vehicle Bus) conformance testing
11	IEC61375-3-4 - Electronic railway equipment - Train communication network (TCN) – Part 3-4: Ethernet Consist Network (ECN)
12	IEC 61377-1 – Railway Applications / Rolling Stock – Combined Testing of Inverter fed alternating current motors and their control systems.
13	IEC 62427 – Railway Application on Compatibility between Rolling Stock and Train detection system

14	IEC 62236 – Railway applications – Electro-magnetic compatibility
15	IEC 61000 – Electro-magnetic Compatibility
16	IEC62625-1 Electronic railway equipment - On board driving data recording system – Part 1: System specification

Table 1.6 UIC Standards

International Union of Railway Standards (UIC)	
1	UIC541- 05 Ed. 2 (2005) -Brakes - Specifications for the construction of various brake parts - wheel slide protection device

Table 1.7 Other Standards

Other Standards	
1	Rolling Stock Industrial Standard (JRIS) – Japan
2	Philippine National Standards (PNS) – Philippines
3	Technical Regulatory Standards on Japanese Railways – (MLIT)Japan

1.16 (Not Used)

1.17 Design life

1.17.1 The Rolling Stock for MCRP&NSRP-South shall be designed on the basis of design life as shown below.

- a. Body / bogie / coupler : over 30 years
- b. Power conversion element, filter capacitor: over 25 years
- c. General electrical parts: over 12 years
- d. Some special parts: above 8 years

1.17.2 If electric parts with a design life shorter than 12 years are proposed, the Contractor shall submit proposals for the Engineer to review.

2 Car Body

2.1 General

- 2.1.1 The Contractor shall ensure the design of each type of car body shell to be as identical as possible, and to be designed to withstand the rigors of the Manila railroad environment for a period of 30 years, without major overhaul or rehabilitation.
- 2.1.2 Car bodies shall be as smooth in appearance as possible, with no untoward protrusions in evidence.
- 2.1.3 The train design shall incorporate design features, which guarantee a high level of safety for the passengers and train crew.
- 2.1.4 The car body design shall incorporate a function of anti-climbing on both ends of the car to prevent one car from climbing over another in the event of a collision.
- 2.1.5 The car body, including doors and windows, shall be water tight under all operating conditions, including passage through a train washing facility.
- 2.1.6 Water deflecting gutters shall be installed on the roof along the entire side of the car and provided with suitable down spouts. The gutter shall be continuous to ensure controlled drainage at the corners of the car. The gutter design shall ensure water shall not spill over the gutter onto the car body side or onto the platform when the Rolling Stock consist is braking or accelerating into stations. Water drainage shall not directly fall/splash to underbody equipment. Rainwater downspout shall be extended just appropriately to allow water to drain down without causing any splashing to the under-floor equipment.
- 2.1.7 The Contractor shall provide suitable repair procedures for car body damage.

2.2 Materials and Construction

- 2.2.1 The car bodies including but not limited to the roof, car body shell, flooring support sheet, etc. shall be manufactured from stainless steel or aluminum alloy, which shall provide excellent performance in relation to:
 - a. Corrosion resistance;
 - b. Resistance to chemical attack;
 - c. Long term structural performance;
 - d. Aesthetic qualities; and
 - e. Low maintenance requirements.
- 2.2.2 Other materials such as steel, carbon steel or etc. that comply with the requirements specified herein, will be accepted subject to the Engineer’s review.
- 2.2.3 The Contractor shall ensure that no materials are to be installed or used on the train which could be damaging to the short or long term health of passengers, train crew, cleaning, environment and maintenance/repair staff.
- 2.2.4 All body panels shall be free from wrinkles and other imperfections, and shall be flat within 2 mm in any 1 m span. Materials shall be suitable for current repair operations (cutting, welding, etc.). Materials shall be in accordance with the relevant standard, appropriate for the application. Particular attention shall be paid to fatigue limit, corrosion and material degradation with weather elements and time.
- 2.2.5 The use of the following materials in the construction of the train shall be restricted and only subject to prior agreement with the Engineer:
 - a. Ceramic fiber;

- b. Rockwool;
 - c. Urea formaldehyde;
 - d. Polyethylene foam;
 - e. Polyurethane foam;
 - f. Polyurethane rigid mouldings; and
 - g. Encapsulated lead.
- 2.2.6 The Contractor shall submit details, including Material Safety Data Sheets (MSDS), for all proposed materials to be handled by the maintainer of the train to the Engineer for review.
- 2.2.7 The exterior of the car body shall be polished finish stainless steel or aluminum left un-painted. The doors shall also to be made with stainless steel skin or aluminum having the same finish as the car body. In case where the cab exterior is other than stainless steel, then painting shall be required. The Contractor shall submit the painting specifications for the Engineer to review.
- 2.2.8 The underframe members shall be made of stainless steel or aluminum. Any component parts of the underframe that are made of high tensile steel or aluminum shall be painted with a half gloss black paint system, which has been proven in metro rail transit and/or similar applications. It shall provide durability and good resistance to abrasion, moisture, oils, and the track work environment, to corrosion of coated metalwork and to car cleaning. The Contractor shall submit the painting specifications for review by the Engineer.
- 2.2.9 All painted surfaces shall match and display a uniformity of color throughout its service life. The paint preparation and finish shall be such as to enable a satisfactory re-coat of part of the vehicle body in the event of localized repair.
- 2.2.10 The paint system shall include the Contractor's value of the paint materials such as smoke generated in the event of fire. Surface preparation requirements, number of coats and thickness with application instructions shall be provided for the Engineer’s review.
- 2.2.11 The performance of the paint finish including scratch resistance, impact resistance, chip resistance, abrasion resistance, and paint adhesion and paint elasticity shall be in accordance with recognized internationally approved standards.
- 2.2.12 The fittings and materials shall be easily cleaned (paint, graffiti, glue, etc.). They shall therefore withstand frequent use of various cleaning products (alkaline or acid detergents, petroleum solvents, mechanical action of brushes) without losing their color or a noticeable deterioration of their surface aspect.

2.3 Structural Requirements

2.3.1 General

- 2.3.1.1 The car body shells shall be of integral construction as well as designed and tested to withstand the loading conditions described herein. The Contractor shall submit a stress analysis for the review by the Engineer. The stress analysis shall include the use of a suitable Finite Element Model (FEM), supported by classical hand analysis for detailed components.

2.3.1.2 The Contractor shall ensure the entire car body structure, bogies, bogie attachments, equipment supports, doors, seats, and interior appointments, are designed in accordance with this ERT and in compliance to JIS E 7106 (2018) or equivalent standards.

2.3.1.3 The Contractor shall ensure the car body structure and all car bodies, bogie and axle mounted components have a minimum design fatigue life of at least five (5) years in excess of the declared service design life. The Contractor is required to submit supporting calculations to demonstrate compliance, with the calculations taking into consideration the operating environment.

2.3.2 End Loading and Deflection Requirements

2.3.2.1 The car body shell shall be designed and tested to withstand a compressive load of 490 kN and tensile end load of 350 kN applied through the draft gear attachment points, in combination with the most adverse vertical loading associated with the worst loading conditions. For all load cases, all car body members shall remain elastic, with no evidence of buckling.

2.3.2.2 The car body shell shall be designed and tested to ensure that under worst loading conditions positive camber exists between bogie centers. The Contractor shall ensure, and must demonstrate by test, that all doors operate freely under all car body loading conditions, and shall not disengage from their guide ways under the lateral loading conditions exerted by crush-loaded passengers.

2.3.2.3 The Contractor shall also design and test the door posts, the corner posts and the driver’s cab end structure in accordance with the latest industry practices.

2.3.2.4 The end beam shall have sufficient strength for towing another train.

2.4 Crash Worthiness Requirements

2.4.1 Condition of the crash worthiness design shall be head-to-head collision between two identical cab cars at tare weight, having the same mass at relative speed between them 25km/h on level and tangent track.

2.4.2 The car body design shall incorporate a function of anti-climbing on both ends of the car to prevent one car from climbing over another in the event of collision.

2.4.3 The Contractor shall consider the crash worthiness or the car design is in accordance to the Japanese Ministerial Ordinance, MLIT or EN 15227 C-II or equivalent, subject to the Engineer’s review.

2.4.4 In case the Japanese Ministerial Ordinance, Technical Regulatory Standards on Japanese Railways is applied, the cab car shall absorb the collision energy by providing a controlled deformation and collapse of areas of the vehicle which are unlikely to be occupied by the train crew and passengers, to absorb the collision energy and to reduce the deceleration on the train crew and passengers. This shall be validated by the computer simulation such as Finite Element Method (FEM).

2.4.5 The Contractor shall submit the details of the design cases, together with the validation process to be adapted, to the Engineer for review.

2.5 Jacking and Lifting Requirements

- 2.5.1 Jacking and lifting points/pads shall be provided for normal maintenance operation, sized and positioned to accept lifting equipment. In addition to these jacking and lifting points, emergency jacking and lifting points shall also be provided at all four corners to allow jacking/ lifting under emergency situations, including derailment.
- 2.5.2 The locations of all jacking and lifting points shall be clearly accessible and marked on the car body.
- 2.5.3 The car body shell shall be designed and tested to allow an empty car, with bogies attached, to be lifted at the extreme ends at the bolster jacking pads, or any combination thereof (particularly during re-railing operations), without exceeding the yield strength of any portion of the car body.

2.6 Car Roof

- 2.6.1 Roof construction shall be sufficiently robust as to allow several maintenance personnel to walk over the roof at one time, without causing undue deflection or permanent deformation. Rain gutters shall run for the full length of the cars to prevent the spillage of rainwater over passengers when the train is entering or leaving stations. Both ends of the car shall have gutters with adequate water drainpipe that runs to the lowest possible point under the car.
- 2.6.2 A roof mat under and around the pantograph area shall be installed for electrical insulation and anti-slip protection. In addition, an anti-slip surface shall also be provided along the side of the roof covering the whole length of the car.

2.7 Floor

- 2.7.1 The floor and its mounting structure shall be designed to withstand any loading condition specified herein, for over 30 years in normal operation of the train. Transverse joints shall be located over car body structural members and away from doorways.
- 2.7.2 All exposed edges of the panels, including openings for ducts and conduits, and joints between panels shall be waterproofed and adequately sealed. The floor design shall allow the floor covering to be removed without damage to the floor sub-structure.
- 2.7.3 Floor covering panels shall be insulated from the metallic structure by elastomeric tape or equivalent. At all door openings, the floor shall have a weather tight connection with the threshold plates. Floor covering materials and installation shall be in accordance to the provision of Sub-Clause 5.4 Flooring of this ERT and shall be compliant to the Fire Safety requirements specified in Sub-Clause 21.8 Fire Safety.

2.8 Equipment Mounting

2.8.1 General

- 2.8.1.1 Equipment arrangement, for weight distribution purposes, on all cars shall be as even as possible under W0 loading conditions. Loading difference at W0 condition, between axles in same bogie shall not be more than 1 metric ton and loading between wheels in an axle shall be less than 10%.
- 2.8.1.2 All equipment mounts shall meet the requirements of Sub-Clauses 1.9 Noise Vibration and Aerodynamics and 1.11 Maintainability Requirements of this ERT and shall have a fatigue life of not less than 30 years.
- 2.8.1.3 Equipment shall be logically grouped into enclosures, which shall meet the requirements of Clause 21 Material and Workmanship of this ERT. Care shall be taken to ensure that the equipment within the enclosures is readily maintainable, taking into consideration the required maintenance interval. Mounting of equipment enclosures/boxes shall be made to allow easy access and opening given the constraints of the maintenance pit/facility.
- 2.8.1.4 All equipment and corresponding cases shall be mounted such that removal and replacement of each is possible without requiring the removal of other major equipment or cases. Similar but non-interchangeable parts shall have different mounting arrangements, to ensure against mistakes in fitting.
- 2.8.1.5 The Contractor shall ensure that safety mounts are provided for all underframe mounted equipment to prevent derailment risk in the event of main mounts failure in service. Similarly, equipment enclosures shall have the doors securely attached to prevent falling off and causing derailment or other damage.
- 2.8.1.6 The Contractor shall ensure that all fasteners are of the same material when attaching components to the car body and be of the same grade.

2.8.2 Cabin and Saloon Access Handrails and Steps

- 2.8.2.1 The Contractor shall ensure that a set of steps with non-slip treads and handrails are provided at each driver’s door to ensure the drivers safety when boarding and exiting the car when not at platform level.
- 2.8.2.2 The Contractor shall ensure that easy access steps with non-slip treads and handrails fit for purpose will be provided at each passenger side entrance door on both sides, this will allow passengers to easily and safety exit the cars during evacuation circumstances when the car is not at platform level. Signage and instructions on how to alight from the train safely shall be provided for each passenger door.
- 2.8.2.3 The stiffness and strength of the handrails and their connections shall be designed and tested to ensure that they shall withstand the rigors of use and the environment. They shall be designed and tested to withstand, without permanent deformation, a load of 1.3 kN applied at the midpoint of the span.
- 2.8.2.4 The stiffness and strength of the steps and their connections shall be designed and tested to allow use by a person exerting a force of 1.3 kN (load applied at a 45 degree angle), without permanent deformation.

2.9 Evacuation

- 2.9.1 The ladders for evacuation at where there are no evacuation passages shall be mounted on the both sides of each vehicle. Two ladders shall be mounted on the one side (The total of four ladders shall be mounted). In case of evacuation from inside of vehicle to on-ground through the saloon doors, the passengers shall be able to evacuate by using these Ladders safe and quickly as possible.
- 2.9.2 The steps for evacuation used at where there is evacuation passage along the line shall be mounted on the both sides of each saloon, because there is the gap between train and evacuation passage. It is necessary that passengers can use this feature easily.

3 Bogies

3.1 General

- 3.1.1 The Contractor shall ensure the bogies supplied with the cars are of service proven design.
- 3.1.2 The bogies shall be designed to operate safely and reliably for the service life of the train.
- 3.1.3 The cars shall be supported on twin axle bogies incorporating a primary and secondary suspension system.
- 3.1.4 The bogies shall be designed and constructed to minimize the unsprung mass including any attachment to the axle and shall provide service for a period of not less than 30 years, under normal use and maintenance.
- 3.1.5 Bogies shall be designed and manufactured such that as many components as practicable are fully interchangeable. All motor bogie assemblies shall be fully interchangeable, similarly all trailer bogie assemblies. The entire bogie shall be suitably protected against corrosion and adequately painted.
- 3.1.6 Provision shall be made in the bogie design to allow vertical mechanical adjustment to compensate for wear. It shall be possible to adjust car body height for wheel wear without having to remove the bogie from the car. The design shall allow for lifting the bogie with the car body.
- 3.1.7 Sufficient number of shims or liners shall be supplied for adjusting body height.
- 3.1.8 Motor bogies shall utilize an individual motor driving each axle, and the motors shall be mounted on the bogie frame. Bogies shall be as light as possible, commensurate with meeting the requirements of this ERT.
- 3.1.9 The bogies shall be compatible with the underfloor wheel turning machine to be installed at the workshop without the need for removal of bogies or disassembly of any major parts from the bogie or the car body or to add interfacing hardware. The Contractor shall ensure that the bogie frames are provided with lifting eyes of sufficient strength at four points to permit level lifting and transportation by shop crane of the fully assembled bogie.
- 3.1.10 Slewing rings shall be provided with an adequate number of standard grease fittings. If a bolster-less connection is used, equipped with center pin and friction plates, the material and design of the friction plates shall not cause undue noise or any residual sound during start of traction and braking. The Contractor shall submit a detailed study of the friction plate properties and performance for review by the Engineer.
- 3.1.11 The bogies shall be capable of being disconnected and reconnected to the car body with minimal operational requirements. The maximum time to remove and replace a bogie with an exchange bogie shall be less than two (2) hours.
- 3.1.12 The bogie shall be configured such that equipment is positioned and oriented in a manner that facilitates access for maintenance. The bogie design shall include the mounting arrangements for the on-board signaling equipment, which shall include, but not be limited to:

- a. the location and mounting of velocity sensors (considering signalling system and ATO)
 - b. mounting arrangements and termination of the associated cabling.
- 3.1.13 Guard irons shall be mounted to bogies at each end of train set.
- 3.1.14 The major component of bogie such as wheel profile and so on, Contractor shall propose the most suitable specifications based on calculated results such as the estimated derailment coefficient ratio described in Technical Regulatory Standard on Japanese Railway issued by MLIT including public notice and Approved Model Specification, limited speed for shunting and shall be given Notice of No Objection by engineer. Moreover, before start of business, contractor shall measure Q/P for all running section, which include reverse running operation or single line parallel operation during emergency situation, by running actually at normal speed and low speed (necessary section), and shall confirm that ratio of the results to limited derailment coefficient, calculated by Nadal’s formulation, are lower than predetermined values. If there are sections that the values are higher than predetermined values, the Contractor shall do as much as the Contractor can and report it the Engineer.

3.2 Suspension System

3.2.1 General

- 3.2.1.1 The suspension system shall comprise a primary and secondary suspension system, the characteristics of which shall provide good riding comfort, low transmissibility of vibration to the car body and minimize impact and vibration noise.
- 3.2.1.2 The primary suspension shall be equipped with service-proven coil springs and air springs shall be used for the secondary suspension.
- 3.2.1.3 The material used in the secondary suspension shall be ozone protected. The bogie design shall provide good performance on curves to minimize wheel noise and wheel/rail wear and unnecessary wheel unloading.
- 3.2.1.4 The suspension system shall be such as to ensure that the train remains within the Rolling Stock gauge under all conditions of passenger loading at static condition and maintain sufficient clearance between the structure gauge under all combinations of passenger loading, car speed consistent with the system’s track curvature / speed restrictions and track curvature including super-elevation. The cars must sustain clearance under the conditions of deflated or over-inflated air springs, broken primary springs, etc.
- 3.2.1.5 The rotational resistance of the bogie/car body interface and the bogie suspension elements shall be such as to minimize excessive wheel flange contact and, hence, minimize wheel squeal and wheel/rail head wear, while preventing yaw instability (hunting) throughout the car’s speed range.
- 3.2.1.6 The bogies shall be designed to allow the complete cars to meet the ride quality requirements of Sub-Clause 1.10 Ride Quality of this ERT.

3.2.2 Primary Suspension

- 3.2.2.1 The primary suspension shall be designed to provide the required degree of wheel set guidance and to minimize wheel flange wear. However, wheel set yaw stiffness and damping shall not be such as to allow a yaw instability condition throughout any portion of the car speed range.
- 3.2.2.2 Primary suspension vertical stiffness shall not be so great as to impart undue forces on the rail under dynamic conditions, and shall be sufficiently flexible to prevent the degree of wheel unloading that would cause a derailment in any level of deflection in all conditions of track irregularities, curvature, super-elevation, etc., consistent with car speed.

3.2.3 Secondary Suspension

- 3.2.3.1 The secondary suspension shall consist of air springs, controlled via adjustable levelling valves, which shall provide a relatively constant floor height to avoid roll and yaw, and a passenger tripping hazard. Vertical and lateral dampers may be installed, if required, to control bogie to car body oscillations.
- 3.2.3.2 The air spring pressure shall also be used to provide a signal to the load sensor system to control car tractive effort and braking forces under all car-loading conditions.
- 3.2.3.3 Emergency secondary springs shall also be provided to support the car body in the event of ruptured air springs.
- 3.2.3.4 To prevent excessive car body lean should one air spring rupture or leak, the air springs on each bogie shall be interconnected using a pressure differential valve.

3.2.4 Wheel Unloading

- 3.2.4.1 The bogies shall be designed to enable the safe operation of the car on the most adverse track condition, with any combinations of air springs deflated.
- 3.2.4.2 Under above condition, the maximum unloading of any wheel shall not exceed 60% of the nominal wheel load. The nominal wheel load is defined as each individual measured wheel load with the car standing on a straight and level track.

3.3 Bogie Frame

- 3.3.1 The bogie frame shall be welded steel construction, manufactured from weather-resistant high tensile carbon steel compliant to JIS E 4207 or equivalent standards, capable of withstanding heavy duty, with the design incorporating adequate safety margins. The bogie frame construction shall be consistent with good mechanical design and be as light as possible. Use of cast steel inserts of acceptable grade in fabrication of the bogie is permissible.
- 3.3.2 The frame shall be of a simple design requiring a minimum of machining. All frame attachment points shall be readily accessible for inspection and maintenance purposes. The bogie frame shall be suitably protected against corrosion and adequately painted.
- 3.3.3 The composition and physical and mechanical properties of the steel shall be fully documented and reviewed by the Engineer.
- 3.3.4 The bogie frame shall be fabricated of steel construction made of cold or hot rolled plates and forged and cast parts. It shall be a welded hollow girder construction and designed in shape of an H.
- 3.3.5 Structural design shall be considered to reduce any stress concentration. If possible, measures shall be taken to remove welding stress of bogie frame.
- 3.3.6 The welded design shall also be fully substantiated by the Contractor through analysis and test particularly regarding limitation of fatigue stresses in welded zones.

3.4 Wheels, Wheel Sets and Axles

- 3.4.1 Wheels shall be of a proven design from a reputable manufacturer.
- 3.4.2 The wheels shall be compliant with the requirements for JIS E4502 or equivalent standards for 1435 mm gauge.
- 3.4.3 Wheel sets shall be protected using a paint system, which shall protect the wheel sets from damage by corrosion for at least the period between bogie overhauls without maintenance.
- 3.4.4 The Contractor shall submit comprehensive details of the wheel set design. The submission shall include, as a minimum, axle detail drawings, axle design calculations, wheel detail drawings, wheel design calculations and wheel sets assembly drawings and procedures.
- 3.4.5 Easy access shall be provided to both ends of all axles to allow ultrasonic testing of the axles. It shall be possible to carry out ultrasonic testing with the wheel set in situ under the cars.
- 3.4.6 The Contractor shall submit procedures for testing of a free-standing assembled wheel set and for testing of a wheel set in situ under a car. It shall include the location of testing and refer to test standards.
- 3.4.7 The wheel set shall be in compliance with requirements as per JIS E 4504 or equivalent standards.
- 3.4.8 The axle shall be designed in accordance with JIS E 4502 or equivalent standards.
- 3.4.9 Wheels, axles, drive gears and axle bearings shall be assembled on axles by an interference fit method.
- 3.4.10 The objective is that the wheels shall achieve a wheel flange wear rate of less than 0.02 mm/1000 km under the designed civil and track work maintenance tolerance.
- 3.4.11 The Contractor shall carry out bearing life calculations to demonstrate that the selected size of bearing is adequate for L10 bearing life of 1,200,000 km.
- 3.4.12 The housings shall incorporate seals to prevent leakage of grease and infiltration of water and dirt and maximize lubricant life. Bearing lubricant shall not, in any circumstances, be allowed to leak or discharge onto the wheel or rail surface. Axles shall be provided with mounting arrangement for disc brake and electrical current return assemblies.
- 3.4.13 Axles shall be designed to withstand the maximum axle load of 16,000 kg and have a fatigue life of not less than 30 years.
- 3.4.14 Full details of the axle, wheel and gear machining details shall be provided, together with process details, including the specific type of lubricants used. The Contractor shall provide the pressing records of all wheel sets in the Car History Books.
- 3.4.15 The wheel back-to-back dimension shall be between 1,359 and 1,362 mm.

3.5 Axle Boxes

- 3.5.1 Axle box bearings shall be of the grease self-lubricated roller type, sealed for life.
- 3.5.2 Bearings shall be sealed by labyrinth seals and if replenishment of grease is required between overhauls, this shall be possible without removing any other equipment. Suitable standard grease fittings shall be provided for this purpose.
- 3.5.3 Any design incorporating a wearing surface between the axle box and the bogie frame shall not be accepted.

3.6 Traction Motor Installation

- 3.6.1 Attention is drawn to the requirements of Sub-Clause 3.1 - Bogies General of this ERT. The design of the motor installation shall also be configured such that should the motor mounting hardware fail, the motor shall not fall from the bogie and cause a derailment.
- 3.6.2 The motor mounting installation shall allow dismounting and mounting without removal of the gearbox from the bogie. The traction motor shall be equipped with an appropriate bearing on the gearbox coupling connection side to assure independent stability and support of the traction motor in all conditions.

3.7 Bogie-Mounted Brake Equipment

- 3.7.1 Pneumatic brake actuators with integral automatic slack adjusters shall be mounted to the bogie frame. One actuator per wheel shall be used.

3.8 Miscellaneous Bogie-Mounted Equipment

- 3.8.1 The bogies shall be equipped with all pertinent equipment needed to meet the requirements of this ERT, including, but not limited to: on-board signaling equipment, speed sensors, dump valves, lifting lugs, piping, cabling, etc.
- 3.8.2 All resiliently mounted equipment on the bogie shall be designed to avoid resonance with all bogie suspension frequencies.
- 3.8.3 On-board sensors shall not be installed near a rotating electrical equipment, to prevent electrical interference.
- 3.8.4 The Contractor shall supply lubrication-free and maintenance-free parts of subcomponents. However, for moving parts where lubrication is necessary, the Contractor shall supply low maintenance parts minimizing lubrication activities.
- 3.8.5 All fasteners of the same material used to attach components to the bogie shall be of the same grade.
- 3.8.6 All grounding shall be in accordance to the provision of Sub-Clause 1.13.4 of this ERT.

3.9 Bogie-to-Car Body Connection

- 3.9.1 The Contractor shall ensure that the bogies are retained by the car body when the car body is lifted, and the bogie-to-car body connection must also retain the bogies in the event of a collision.
- 3.9.2 Bogie/car body connections shall be designed to avoid the transmission of noise and vibration. It shall be physically impossible for connections to be mismatched.

3.10 Bogie-to-Car Body Clearance

- 3.10.1 Under all conditions of movement between the bogies and the car body, including fully inflated and deflated air spring conditions, there shall allow a minimum clearance of 50 mm between bogie-mounted and car body-mounted equipment.
- 3.10.2 This shall include any end of the car having fully inflated air springs, with the opposite end having deflated air springs.

3.11 Structural Requirements

- 3.11.1 Unless otherwise specified, bogies and bogie-mounted equipment shall comply with the industry standard requirements.
- 3.11.2 The Contractor is encouraged to indicate different load cases that would be more appropriate according to their previous experience; supporting data shall be submitted to the Engineer for review.
- 3.11.3 A stress analysis of the entire bogie structure shall be performed using a Finite Element Model (FEM). The model, its type and number of elements, and the criteria used for the acceptability of stress levels shall be subject to the Engineer’s review.
- 3.11.4 In addition, the Contractor shall provide a proof load case and fatigue load case for all bogie and axle-mounted equipment and parts.

3.12 Bogie Maintainability

- 3.12.1 The bogie frame shall be fitted with suitable lifting locations for lifting it off the wheels and axles, for lifting the complete bogie frame during maintenance in the workshop and for re-railing a car or bogie. Jacking pad location shall be provided to match the workshop equipment.
- 3.12.2 In addition, the design of the bogie frame shall incorporate horizontal and vertical pads at diagonal positions for re-railing operations following derailments.
- 3.12.3 The bogies shall be capable of being cleaned using high-pressure hot water or steam jet cleaning equipment, with or without detergents. All closed sections and pockets shall be self-draining or sealed against water ingress. All bearings shall be adequately sealed to ensure that water and cleaning fluids do not enter during the cleaning process.
- 3.12.4 Bogies shall be capable of being disconnected and reconnected easily and with a minimum number of operations by personnel working in pits or alongside the bogies. It shall be possible to easily inspect for correct reconnection without the need for special tools or instruments.
- 3.12.5 It shall be possible for personnel working in pits or alongside the bogie to visually inspect the condition of bogie components, such as brakes and wheel treads, easily and without the use of special tools.
- 3.12.6 The bogie shall provide easy and safe access for all maintenance, including access for the train driver to operate the isolating cocks for bogie-mounted equipment and parking brake manual release.
- 3.12.7 The attachments between the body and the bogie shall be such that if the car is lifted without disconnecting the bogies, the bogies, traction drives and wheel sets shall be retained captive to the car without the need for additional restraints at the time of lifting. No damage shall result to any of the connections as a result of this action.

4 Coupler and Draft Gear

4.1 General

- 4.1.1 The end car in each train shall be fitted with an automatic coupler. It shall be possible to directly couple all the trains running on the NSCR, MCRP and NSRP-South lines without an adapter during train rescue or hauling.
- 4.1.2 In both leading cars, an electrical connecting plug which is necessary for rescue operation by connecting trainsets shall be equipped. Also, an emergency connection cable that connects this electrical connection plug shall be supplied. By using this connecting cable, required functions such as brake command, broadcasting, buzzer etc. shall operate properly.
- 4.1.3 The position of this plug shall be consistent with other trains that run on the same lines. Length and diagram of cable shall be also consistent with other trains that run on the same lines, particularly length of cable shall be determined in consideration of the severest deviations during coupled with other train. Basically, utilization of adapter shall not be acceptable.
- 4.1.4 The Contractor shall provide the required cabinet for housing the emergency connection cable on the train. Alternatively, the Contractor shall provide proper mechanism for retaining the emergency connection cable when it is not in used.
- 4.1.5 All electrical connections shall be made to terminal blocks in junction boxes compliant with IP 65, via jumper cables, using quick connect/disconnect couplings securely locked with wire.
- 4.1.6 Cable hoses shall be made out of high quality, weather and abrasion resistant insulated rubber.
- 4.1.7 The connectors for each cable, if of the same size, shall be keyed differently to prevent misconnection, and shall be color coded to enable connectors to be easily distinguished.
- 4.1.8 In all cases, care shall be taken to ensure that strain relief is provided for all cables leaving the junction boxes, and that all cables are properly supported in suitable cleats, and that no chafing of the cabling takes place under all possible movements of the coupler.
- 4.1.9 The arrangement shall prevent damage from coupling with misaligned couplers, and shall minimize damage to the car body wiring, should excessive tension be applied to the cables in the event of an accident.
- 4.1.10 The couplers shall be designed to prevent the coupler swinging transversely when it is not coupled.
- 4.1.11 The couplers and draft gear shall be capable of withstanding all coupling, buffing and draft loads to be expected in normal and emergency conditions. The draft gear shall be suitably damped and be designed to prevent the occurrence of unduly large dynamic deflection and associated forces under the above condition.
- 4.1.12 The coupler height, measured from the center of the coupler to the top of rail, shall be within 880 mm +10/-15 mm.
- 4.1.13 The Contractor shall provide twenty-six (26) units of automatic couplers and deliver to the CP NS-01 Contractor for use on the maintenance vehicles supplied under the CP NS-01 contract. The delivery location and timing shall be determined during the CP NS-02 and CP NS-01 interface meetings.

4.2 Semi-Permanent Couplers

- 4.2.1 The semi-permanent couplers shall only be coupled or uncoupled in the depot. Pneumatic connections shall be made when coupling the semi-permanent couplers.
- 4.2.2 The semi-permanent couplers shall couple the cars within each 8-cars consist.

4.3 Draft Gear

- 4.3.1 Each coupler type shall utilize rubber, double acting draft gear capable of withstanding all of the loads described in this ERT, and which shall not transmit undue vibrations into the car body.

5 Car Interior

5.1 General

- 5.1.1 The interior of the cars shall be aesthetically pleasing and the arrangement and materials used shall reflect the current best industry practice and standards. All materials used must meet the fire safety requirements of Sub-Clause 21.8 - Fire Safety - of this ERT. The interior arrangement shall allow for easy maintenance, and all edges shall be rounded to the extent possible to preclude passengers, train crew and maintenance personnel injury and to facilitate cleaning.
- 5.1.2 The Contractor shall provide a selection of colored artists renderings for review by the Engineer. Using these as a basis, the Contractor shall work with the Engineer to supply a final set, which shall be used for the color and configuration of the interior arrangements of each type of car.
- 5.1.3 Visible fasteners in the passenger saloon and the driver’s cabs shall be avoided. Fasteners shall be of the tamper-resistant type, manufactured from stainless steel.
- 5.1.4 The Contractor shall also provide design drawings and passenger seating and flow analysis of a floor plan incorporating the use of longitudinal seats for review by the Engineer.
- 5.1.5 The train shall be designed to transport all sectors of the population, including children, passengers with luggage, senior citizens, disabled people, blind or deaf people, handicapped persons, including non-ambulatory persons in wheelchairs.
- 5.1.6 The contractor shall comply with the accessibility and Gender and Development (GAD) guidelines.

5.2 Insulation

5.2.1 Thermal Insulation

- 5.2.1.1 The car body side walls and roof shall be insulated with a suitable grade of fiberglass insulation, which shall have been treated to resist fungus and mildew.
- 5.2.1.2 The fiberglass insulation shall be installed so as to prevent shakedown in service and where accessible shall be suitably protected/covered.

5.2.2 Acoustic Insulation

- 5.2.2.1 Where found necessary by the Contractors’ noise analysis, visco-elastic sound damping material shall be installed in the car to damp noise-generated vibrations.

5.3 Interior Finish

- 5.3.1 Interior finish panels shall be lightweight and of balanced construction to minimize warping under differing temperature conditions. They shall be vandal resistant (impact, graffiti, etc.) and shall have a proven record in rail transit service. The panels shall not fade nor discolor over time.
- 5.3.2 The surfaces of interior finish panels shall be smooth, and no edges shall be created which shall cause dust traps.
- 5.3.3 The interior close-off panels on the side of the car shall be designed to accept information/advertisement cards.
- 5.3.4 Stainless steel kick plates of 150 mm depth with radius coving shall be provided on all exposed vertical surfaces above floor level.

- 5.3.5 The Contractor shall propose and submit three (3) different saloon interior design concepts and three (3) different color scheme for the Employer and Engineer's review and acceptance. Computer generated graphics for each proposed interior design and color scheme shall be provided. The design proposals including material sample board to indicate all design materials and finishes shall be submitted for review and approval. The propose the color scheme shall match the color of the painted car body.

5.4 Flooring

- 5.4.1 The interior flooring shall be supported by the car body underframe structure, which shall be constructed to minimize floor deflection under W3 passenger loading.
- 5.4.2 All floors including floor coverings shall withstand a force of 1000 N applied over an area of 25 mm² without suffering any deformation or marking. The interior flooring shall cover the entire passenger saloon area with transit grade floor covering.
- 5.4.3 To prevent noise due to car deflections, the flooring composition shall be insulated from the metallic structure by a suitable material.
- 5.4.4 The floor design and bonding process shall allow the floor covering to be removed and replaced without damage to the floor sub structure.
- 5.4.5 All saloon floor to wall interfaces shall have a radius to allow easy cleaning and avoid dirt traps.
- 5.4.6 The floor covering shall be required to continue up the side walls to provide a sanitary cove.
- 5.4.7 It is preferred that floor covering is seamless. Where seams do exist, they shall be fully sealed and shall not create a tripping hazard.
- 5.4.8 The Contractor shall offer a contrasting floor covering for vestibule areas compared with the passenger saloon area.
- 5.4.9 The floor covering material shall meet the following performance requirements:
- a. Slip resistance of 0.75 dry and 0.62 wet in accordance with JRIS J0745 or equivalent standards;
 - b. Hardness of Shore A Hardness 85-90;
 - c. Resistance to chemicals in accordance with JIS A 1454 or equivalent standards with noticeable variation; and
 - d. Tensile strength in accordance with JIS K 6251 (or equivalent standards) - 7.3 MPa.
- 5.4.10 The entire floor construction shall be required to comply with the requirements of the Japanese Ministerial Ordinance, MLIT Chapter 8, Section 5, Article 83 (Countermeasures for Fire of Rolling Stock) or equivalent standards.
- 5.4.11 All floor penetrations (for piping, conduit, etc.) shall be suitably sealed against the elements, and be required to comply with the above requirements of MLIT or equivalent standards.

5.5 Ceiling

- 5.5.1 The car ceiling shall present an aesthetically pleasing smooth surface, and shall incorporate lighting fixtures, air-conditioning air outlet grills, public address speakers, etc.
- 5.5.2 The ceiling panels and fixtures shall not vibrate, rattle or squeak during normal service conditions.

5.6 Draught Screens

- 5.6.1 Draught screens shall be provided at each passenger door portal to protect seated passengers from a draught and adverse weather conditions when the doors are opened.
- 5.6.2 The draught screen shall be a safety glazed panel, designed to withstand the in-service forces and shock loads. The draught screen shall have through visibility and be graffiti resistant.

5.7 Passenger Seats and Baggage rack

- 5.7.1 The Contractor shall propose a longitudinal seating arrangement.
- 5.7.2 All seats shall be installed cantilevered off the side wall with no floor support, to facilitate cleaning of floors and storage of passenger belongings underneath.
- 5.7.3 The seats shall be designed and manufactured to MLIT Chapter 8, Section 5, Article 83 or equivalent standards. Details of the specification and testing requirements are to be supplied by the Contractor to the Engineer for review.
- 5.7.4 The seats shall be ergonomically designed and the materials to be used in the seat design shall be water-proof, vinyl, ergonomic (each person's seat is separated by a depression), fire and vandal resistant. Fire performance testing shall be undertaken by the Contractor with review by the Engineer. The seat design shall eliminate gaps that shall trap dirt or liquids and can be easily maintained.
- 5.7.5 The Contractor shall be required to supply documented evidence that the proposed seats have demonstrated trouble-free service in a similar operating environment.
- 5.7.6 Baggage rack shall be equipped above the passenger seat.

5.8 Accommodation for Disadvantaged Passengers

- 5.8.1 The Contractor shall provide space on all cars to cater for people in wheelchairs and people with prams. The prospective wheelchair space shall be prominently labelled on the floor with the appropriate standard sign. Additionally, fully retractable and non-obstructive wheelchair tie downs shall be made available for ready installation for each wheelchair space.
- 5.8.2 Each car shall be equipped with 1 wheelchair space per car and 6 priority seats per car. The disabled and priority seats labels shall be prominently displayed.
- 5.8.3 The car interior space shall be optimized and the free floor area in the saloon shall be maximized and accessible for disabled people with wheelchair.
- 5.8.4 Safety belt shall be provided for wheelchair security.
- 5.8.5 Sufficient handholds shall be positioned at an ergonomic height in the wheelchair area.
- 5.8.6 A high level of color and luminance contrast shall be provided to identify critical features such as doors, steps and hand holds.

5.9 Stanchions and Handholds

- 5.9.1 Suitable stanchions and handholds shall be provided to allow passengers to stand comfortably at all times. All stanchions and handholds shall be seamless, corrosion resistant, round, unpainted stainless-steel tubing.
- 5.9.2 The location and type (shape, size) of stanchions and hand holds shall be submitted to the Engineer for review.

- 5.9.3 The stiffness and strength of the stanchions and handholds and their connections, shall be designed and tested to ensure that they shall withstand the rigors of service and environment.
- 5.9.4 Vertical stanchions and horizontal hand holds shall be designed and tested to withstand without permanent deformation, a load of 1.5 kN applied in any direction at the midpoint. Horizontal handholds shall be designed and tested to withstand, without permanent deformation, a load of 1.5 kN applied at the midpoint of the span.
- 5.9.5 All attachments shall be stainless steel fittings properly cushioned to prevent rattling and shall be such that unauthorized removal or vandalism shall be minimized. All fittings shall permit easy removal and installation for maintenance purposes.

5.10 Strap Hangers

- 5.10.1 The Contractor shall provide strap hangers to the handrails. The strap hangers shall be selected of suitable strength and durability, industry proven.
- 5.10.2 The Contractor shall submit the location and quantity of strap hangers distributed along the handrails to the Engineer for review.

5.11 Windows and Glazing

- 5.11.1 All side windows (except windows in the doors) shall be single glazed with toughened/tempered glass to current railway industry standards. Windows shall be suitably mounted to the car body window frame. The color and degree of tinting shall be reviewed by the Engineer during the design process.
- 5.11.2 The size of the passenger side windows shall allow the maximum entry of natural light into the passenger saloon while maintaining the structural integrity of the car body.
- 5.11.3 Windows shall be capable of withstanding the pressure differentials associated with head-on pressure, passing trains, prevailing winds, etc. The windows and mountings shall also be able to withstand the loads imposed by passengers leaning on them under crush loaded conditions.
- 5.11.4 The mounting of windows shall be able to absorb undue shock without breaking or cracking on the glass.
- 5.11.5 The side windows shall be the openable (with an option to be locked) and flush mounted type, consisting of two sections, with an upper section which can be opened inward and fixed lower section.
- 5.11.6 Window design shall allow all passengers (sitting and standing position) to have good vision on the outside and especially for station information.
- 5.11.7 The body-side and door windows shall be designed to minimize solar gain and provide a level of thermal insulation consistent with the requirements of the air- conditioning system.
- 5.11.8 Glazing shall be readily removed and replaced from outside the car without removal of the interior linings. The Contractor shall provide the related repair procedure.
- 5.11.9 Each window, including glazing, shall have sufficient strength when tested in accordance with JIS R 3213 or other equivalent standards.
- 5.11.10 All side windows shall transmit less than 7% of the incident ultra violet radiation. Body side and door glazing shall be capable of rejecting 50% to 80% solar energy with visible light transmission of 40% to 55%.
- 5.11.11 Glazing of windows on body-side and doors shall resist vandalism. The windows shall be high enough to prevent easy breakage.

- 5.11.12 Window seals shall be designed to prevent ingress of water to the inside of the body sides. The sealing material shall be so selected that it lasts at least until the mid-life interval of car body overhaul.
- 5.11.13 Door windows shall have a window similar to the windows provided in the car body as far as possible in respect of solar gain, thermal insulation, replacement criteria, strength, resistance to pressure, and the transmission of light, and solar heat gain, etc.
- 5.11.14 Door windows shall be replaceable without removal of the door leaf.

5.12 Drivers Cab Windshield

- 5.12.1 The cab front windshield shall be of tempered safety glass meeting the requirements of JIS R 3213. The mechanical and optical properties of the windshield shall meet the requirements of JIS R 3212 or other equivalent standards.
- 5.12.2 The cab windshield shall be bonded directly to the car body window frame. The design shall ensure that, in the event of breakage, sufficient visibility is maintained to operate the train safely for the remainder of the service.
- 5.12.3 Windshield shall be replaceable within a four-hour period at the depot. Glue and sealant shall be of a type to cure to a level sufficient for the train to re-enter revenue service 8 hours after the completion of the installation of the windshield.
- 5.12.4 Sun visor(s) shall be installed to provide protection from direct and reflected sunlight over as large an area as possible.
- 5.12.5 Windshields shall be provided with an external electric wiper/washer units and defogger unit. The driver shall be able to control the active cab windshield wipers, washers and defogger via the active driver’s desk. A fan defogger will not be acceptable. The defogger shall have no adverse effect on the windshield including overheating in direct sunlight.
- 5.12.6 The windshield wipers, washers and defogger equipment shall not impair the driver’s line of sight. The windshield wipers shall include adjustable speeds of operation with intermittent function and “park” position. At least 80% of the width and 60% of the height of the windshield shall be swept over a complete cycle. The washer unit shall be provided with at least 10 liters of water reservoir, with visual water level gauge, located for easy filling from ground level outside the car.
- 5.12.7 The driver’s cab side windows shall be capable of being opened and positioned so the driver can view the length of the train. An open window shall maintain its set position at all times that the train is in motion. The driver’s cab windows shall also meet all the requirements of Sub-Clause 5.11 - Windows and Glazing - of this ERT.

5.13 Signs and Decals

5.13.1 General

- 5.13.1.1 Signs and decals shall be provided in both Tagalog and English languages.
- 5.13.1.2 All decals shall be vandal and graffiti resistant, and shall be edge-sealed. The art work shall be submitted to the Engineer for review prior to manufacturing.
- 5.13.1.3 The Engineer will prepare the complete list of signs and interact with the Contractor during the design stage.
- 5.13.1.4 The number and location of the signs and decals, and the decal materials used, shall be reviewed by the Engineer.

5.13.2 Passenger Saloon Signs and Decals

5.13.2.1 Decals shall be installed inside the passenger saloon, as follows but not limited to:

- a. No smoking decals;
- b. No eating, no drinking;
- c. System route maps (including places of interests);
- d. Door warning notices;
- e. Elderly/disabled seats;
- f. Emergency notices;
- g. Car body number;
- h. “No Littering” notices;
- i. Hold to handrail/hand grip notices;
- j. Fire extinguisher marker; and
- k. Wheelchair space.

5.13.3 Car Exterior Signs and Decals

5.13.3.1 Decals shall be installed on the car exterior, as follows but not limited to:

- a. The service livery;
- b. Car number;
- c. NSCR Logo;
- d. Identification of lifting and jacking points;
- e. Identification of maintenance requirements;
- f. Door gap and height reminders; and
- g. Safety reminders.

5.13.3.2 The Engineer will prepare a complete list of signs and decals, and liaise with the Contractor during the design stage.

5.14 Miscellaneous Equipment

5.14.1 Fire extinguishers of the approx. 3.5L chemical water type, or equivalent, shall be provided. One shall be fitted in each driver’s cab and two shall be fitted in each passenger saloon.

5.14.2 Those in the passenger saloon shall be recessed in a breakable glass cabinet, but shall be readily accessible.

5.15 Driver's Cab

5.15.1 General

- 5.15.1.1 A driver’s cab shall be provided at each end of the train. The driver’s cab shall be equipped with an interior door and two side doors. Each door can be locked inside and outside by a key. The doors shall be manufactured as provided for in Sub-Clause 7.2 - Cab Doors - of this ERT.
- 5.15.1.2 As part of the design process, the Contractor shall manufacture a full sized, fully equipped cab mock-up for the purpose of evaluating the design.
- 5.15.1.3 The driver’s cab layout shall be agreed between the Contractor and the Engineer.
- 5.15.1.4 The Contractor shall finish the driver’s cab in neutral tones to create a pleasant environment without visual distractions and it shall be designed to reduce glare and the effects of sunlight at low angles on screens. Low gloss levels shall be provided in the design of the driver’s cab console.
- 5.15.1.5 The layout shall be designed to consider the installation of ATO and PSD, and comply with the requirements of international standards, including but not limited to:
 - a. MLIT Article 72 Ergonomic principles in the design of work systems or other equivalent standards;
 - b. ISO 9241 (parts 2, 5 and 11) Ergonomic requirements for office work with visual display terminals (VDTs) or equivalent; and
 - c. JIS Z 8502 Ergonomic principles related to mental workload or other equivalent standards.
- 5.15.1.6 The interior door and partition wall between the driver's cab and interior end car passenger area shall be designed to maximize the visibility but without compromise the safety of the drivers. Contractor shall submit the driver's cab design for Employer and Engineer's review.

5.15.2 Driver's Seat

- 5.15.2.1 The Contractor shall place the driver's seat in the center of the cab to ensure that the driver’s sighting requirements are achieved. The cab size and crew seat locations shall ensure unrestricted movements to and from the cab access doors.
- 5.15.2.2 Each driving position shall be fitted with a fully adjustable, ergonomically designed, railway service proven gas cylinder suspension equipped driver’s seat.
- 5.15.2.3 The seat shall have as a minimum the following adjustments:
 - a. Vertical seat height;
 - b. Horizontal distance from console (forward/backward);
 - c. Backrest angle;
 - d. Lumbar support;
 - e. Head rest; and
 - f. Revolving movement with locking system.
- 5.15.2.4 An additional folding seat shall be provided inside the drivers’ cab for the use of other service staff.
- 5.15.2.5 The Contractor shall propose and submit three (3) different driver's seat design concepts and color scheme for the Employer and Engineer's review. Computer generated graphics for each proposed design shall be provided. The design proposals including material sample board to indicate all design materials and finishes shall be submitted for review and approval.

5.15.3 Cab Air-Conditioning System

- 5.15.3.1 Conditioned air shall be ducted from the passenger compartment air supply, through adjustable diffusers in the cab ceiling, to maintain the specified car interior temperatures and humidity.
- 5.15.3.2 The driver’s cab air supply design, arrangement and calculations shall include the increased solar load through the cab's windshield and the heat load produced by the equipment inside the driver’s cab.

5.16 Cab Controls of Driver’s Cab

5.16.1 General

- 5.16.1.1 The driver’s controls shall be incorporated into a modern, ergonomic console design located at the cab front end structure. All controls, instruments, displays and gauges shall comply with the requirements of ISO 9355 - ergonomic requirements or equivalent for the design of displays and control actuators.
- 5.16.1.2 Any control operation and train condition shall be recorded in the event recording device of Train Management System (TMS) in both leading cars. The memories of the event recorder shall be physically located in a position on the train such that it shall be extremely unlikely to receive damage during a train collision. The Contractor shall ensure the security of the data. The data stored in the memory shall be readily available to support any accident investigation.
- 5.16.1.3 The Contractor shall demonstrate by using cab mock-up that the display panel and lamps are located where sunlight will not affect the display.
- 5.16.1.4 The following driver’s controls shall be provided on the console as a minimum:
 - a. Communications cluster, consisting of a telephone handset, voice synthesizer, etc.;
 - b. Door controls cluster;
 - c. Train management system HMI, (TMS monitor that can be operated by touch);
 - d. Driver's controls cluster, consisting of the master controller, driving mode switch, reverse lock switch and master key switch;
 - e. On-board signalling cluster;
 - f. Speedometer;
 - g. Security brake push button, for the application of emergency brake, automatic lowering of pantograph and opening of line circuit breakers;
 - h. P.A. cluster, consisting of passenger alarm lit push button and microphone;
 - i. Windshield washer/wiper cluster, with wiper speed control (high speed, low speed, intermittent-infinitely variable);
 - j. Vigilance alarm buzzer;
 - k. Loud speakers;
 - l. On-board signalling buzzer;
 - m. Fault buzzers;
 - n. On-board signalling selector;
 - o. ATP cut-out switch; and
 - p. Miscellaneous switches - headlight (high/low beam), gauges/voltmeter - such as line voltage and horn, brake cylinder pressure, main reservoir pressure, etc.

5.16.2 Master Controller

5.16.2.1 The master controller shall control motoring and braking in several steps in an adjustable linear manner, as follows:

Table 5.1 Master Controller

	Handle Position	Function
1	Vertically upright	Neutral
2	Forward from the vertical position until the handle reaches its end position with a spring return device.	Propulsion, with acceleration increasing according 4 steps with handle movement.
3	Backwards from the vertical position until the handle engages a a spring loaded detent.	Normal braking, with the effort increasing according to 7 steps with handle movement.
4	Backwards from the spring loaded detent in 3, until the handle reaches its end position.	Emergency braking.

5.16.2.2 The master controller shall be ergonomically designed to minimize unnecessary physical strain and fatigue to the operator.

5.16.2.3 The master controller shall be locked/unlocked by the driver’s key and reversing switch.

5.16.2.4 When the driver’s key is in the “ON” position and reversing switch is in the forward or reverse position, the master controller shall be unlocked.

5.16.2.5 The driver’s key shall itself be captive when the master controller is not in the predetermined position.

5.16.2.6 The driver’s key shall itself be captive when the reversing switch is not in the predetermined position.

5.16.2.7 Only one cab on the train consist shall be able to be activated at any one time.

5.16.3 Reversing Switch

5.16.3.1 The reversing switch has 3 positions, as follows:

Table 5.2 Reversing Switch

	Reversing Switch Position	Direction of the train
1	Vertically upright	OFF position
2	Forward from the vertical position	Forward
3	Backwards from the vertical position	Reverse

5.16.3.2 When the driver’s key is in the ON position and the master controller is in the predetermined position, the reversing switch shall be unlocked.

5.16.4 ATP Mode

5.16.4.1 The ATP mode shall be locked by the Driver’s key and a sealed switch for ATP cut-out shall be provided.

5.16.4.2 The train shall be designed to make provision for an additional on-board signaling system.

5.16.4.3 Details of the signaling system will be provided by the CP NS-01 Contractor during the interface meeting as described in ERT Clause 16.

5.16.5 Driver’s Vigilance System

5.16.5.1 Within the master controller handle or in its vicinity, there shall be a button which must be pressed and released on a regular, predetermined basis, to prevent the application of emergency braking.

5.16.5.2 The feature shall be coordinated such that either action described as follows prevents brake application:

- a. If within a certain period of time there is no master controller operation by the operator, the alarm sounds; and
- b. Within 5 seconds after the alarm sounds, if there is no operation of the confirmation button, or no master controller operation, the emergency brake is operated.

5.16.5.3 The idling time limit for alarm shall be able to be adjusted by the maintainer.

5.16.6 Miscellaneous Cab Equipment

5.16.6.1 The cab shall incorporate a locker for storing emergency equipment (first aid kit, flashlight, etc.) and another one for storing the driver's personal belongings (baggage, etc.)

5.16.6.2 All emergency equipment shall be indelibly marked with the name or logo as instructed by the Engineer.

5.16.6.3 Crew keys and equipment box keys shall be identical and preferably exchangeable.

5.17 Car Fire Safety and Protection

5.17.1.1 Materials to be used for car construction shall provide fire propagation resistance complying with relevant requirements in the Japanese Ministerial Ordinance, MLIT Chapter 8, Section 5, Article 83 (Countermeasures for Fire of Rolling Stock), Fire Code of the Philippines or equivalent.

5.17.1.2 A fire hazard assessment for each car shall be submitted by the Contractor for review by the Engineer. Assessment shall reflect the “worst” three-minute release rate values of the materials that are specific to the car.

5.18 Accessibility

- 5.18.1.1 The Contractor shall comply with national philosophy of accessibility requirements to ensure that the works to be delivered are safe and reliable for railway operations.
- 5.18.1.2 Access to equipment shall require minimum effort and shall not impose excessive strain to maintenance personnel.
- 5.18.1.3 The layout and mounting of equipment shall facilitate inspections, testing and replacement during fault finding. Adequate access shall be provided so that when replacing one particular component it will not be necessary to remove other components which may block the access.
- 5.18.1.4 Access covers the doors of equipment cases and cabinets shall be provided with quick release fasteners to reduce the time and effort for removal and restoration.

6 Lighting

6.1 General

- 6.1.1 The lighting circuits shall include at least:
 - a. Driver’s cab lights;
 - b. Passenger saloon lights;
 - c. Passenger saloon emergency lights; and
 - d. Exterior lights.
- 6.1.2 The Contractor shall ensure all lighting fulfills the mandatory requirements of JIS E 4016 – Illuminance for Railway Rolling Stock – Recommended levels and measuring methods or other equivalent standards.
- 6.1.3 All interior lights shall have a level of protection of at least IP54. All exterior lights and switches shall have a level of protection of at least IP65.
- 6.1.4 Care shall be taken to ensure that flickering does not occur during train starting or normal running.
- 6.1.5 Individual lights circuits shall be protected from abnormal currents via separate miniature circuit breakers. Each light circuit shall be controlled by separate switching.
- 6.1.6 The lighting functionality and operation shall be agreed through the design review process.

6.2 Driver’s Cab Lights

- 6.2.1 Lighting in the driver’s cab shall be able to be controlled by the driver. In addition to general lighting a driver’s spot light shall be provided for the purposes of reading.
- 6.2.2 Lighting in the driver’s cab area shall be powered via the battery system when the auxiliary power supply is not working.
- 6.2.3 The Contractor shall provide LED lighting which is no less than 100 lux measured on vertical plane 500 mm above driver seat level.

6.3 Passenger Saloon Lights

- 6.3.1 The driver shall be able to control the lighting in a train consist. The lighting arrangement shall be configured to provide continuous uniform lighting, to eliminate glare and to minimize the creation of shadows.
- 6.3.2 The Contractor shall provide LED lighting in the passenger area that is modern and aesthetically pleasing with a mass production of over 5-year service proven history. The lighting minimum declared life shall be 50,000 hours. The lighting shall be powered by 220 V ac supply.
- 6.3.3 The lighting intensity at passenger sitting reading level (500 mm above seat level) shall be no less than 400 lux and at 850 mm above floor level no less than 200 lux. Passenger saloon lighting shall have no significant dark areas behind the diffusers. The main passenger lights circuit shall be protected from abnormal currents via a separate circuit breaker.

6.4 Passenger Emergency Lighting

- 6.4.1 A reduced level of passenger saloon lighting shall be powered from batteries if the overhead power is not present or the auxiliary power supply has failed.

- 6.4.2 Emergency lighting at a minimum average illumination of 10 lux shall be provided by LED lighting with the capacity to allow lighting to be provided within all passenger saloons, at all inter-car locations and in the doorway areas, which shall be powered from the battery for at least 90 minutes.
- 6.4.3 The emergency passenger lights circuit shall be protected from abnormal currents via a separate miniature circuit breaker.
- 6.4.4 When the Auxiliary Power Supply Equipment (APSE) stops, appropriate pieces of these LED lights in one car shall be powered from the battery. Namely, this means these LED lights have also the role of emergency lights.

6.5 Exterior Lights

- 6.5.1 The Contractor shall provide LED-type headlights.
- 6.5.2 The headlight shall have two functions. One is down lighting mode; another is high-beam mode. The Contractor shall ensure that TMS monitor displays when the light is in either state.
- 6.5.3 The Contractor shall ensure that a headlight fault detection system is provided for each train cab, providing fault indication and status information to the driver by TMS monitor.
- 6.5.4 The light intensity of headlights shall comply with Table.7 in the item 5.2.1 of JRIS R 1645 or other equivalent standards.
- 6.5.5 Headlight lamps shall be capable of being replaced, aimed correctly from the outside or inside of the driver's cab easily. The optical axis of the head lamps shall be capable of being adjusted easily.
- 6.5.6 The Contractor shall ensure that the red tail lights or white marker lights are automatically activated based upon the cab activation status as follows:
 - a. Red tail lights displayed - associated cab is not activated, or non-activated cab is at rear of the train, or when both cabs in the train are inactive; and
 - b. White marker light displayed - associated cab has been activated, indicating this shall be the front of the train. The white marker lights on the inactive end cab shall be lit when cars are driven in reverse direction.
- 6.5.7 LED type marker lights shall be provided and combination red/white units may be proposed.
- 6.5.8 The Contractor shall ensure that inspection lights are provided in the vicinity of the underframe mounted equipment. The inspection lights shall be push-button activated from the cab and underframe and shall incorporate design features to ensure that the lights are not inadvertently left on when the train is in operation.
- 6.5.9 Locally switched maintenance/inspection lights shall be installed in the equipment boxes which may need to be accessed periodically (i.e. equipment boxes containing circuit breakers, switches).
- 6.5.10 The Contractor shall ensure that two indicating lights are installed above each door, one inside and one outside. The lights shall be illuminated when the doors open while not lit up when the doors are closed. The lights shall be blinking during the opening and closing cycle of the doors. The lights shall be illuminated together with an indication on the driver’s panel or the TMS monitor when the door is faulty and/or isolated.
- 6.5.11 The Contractor shall ensure that all lights are powered from the low voltage DC power supply system. Should the auxiliary power supply equipment not be operational, the lights shall be powered from the batteries.

7 Doors and Door Control

7.1 Passenger Side Entrance Doors

- 7.1.1 The side entrance-door design and functionality shall be based on a "fail-safe" principle and incorporating high standards of safety and security for the passengers. Design, safety and testing of the passenger doors shall be compliant with MLIT Article 74. Four electrically powered bi-parting doors shall be provided on each side of every car.
- 7.1.2 All doorways shall have a clear opening of 1300 mm and a clear height of 1850 mm. The doors shall be the sliding pocket doors, constructed to prevent hands/finger pinning at the pocket section during operation.
- 7.1.3 Door positions in the car and door pitches shall be complied with Appendix D of ERT.
- 7.1.4 The Rolling Stock shall be a high-floor design, with level boarding from platforms. Wheelchair and mobility-impaired boarding shall not require the use of bridging or lifting devices. The horizontal distance of the passenger door thresholds shall be 1,475 +/- 25 mm from the track center.
- 7.1.5 Doors shall be vibration free and sufficiently insulated against heat and sound transmission. Exterior and interior surfaces of the door leaves shall be finished to match the adjacent surfaces of the car. The doors shall be free from dimples, warping, spot welding depression and any other blemish.
- 7.1.6 When closed, the door leaves shall be capable of withstanding loads imposed by passengers leaning on them under crush loading conditions. The doors shall be designed and tested such that the door leaves sustain such pressure with no permanent deformation. The Contractor shall submit test procedure and results based on best international practices.
- 7.1.7 It shall not be possible for a door to become detached from the car under any operating conditions, including heavy side load from standing passengers or sudden pressure transients.
- 7.1.8 No single defect or failure of any part of any door system shall produce a situation capable of causing injury to passengers.
- 7.1.9 Door guides and supports shall be mounted within the section of doorway protected by the door seals and shall not allow ingress of dirt, debris, or any other foreign matter likely to result in excessive wear or incorrect operation of the door equipment.
- 7.1.10 The Contractor shall indicate the amount of time required to replace a door leaf, adjust it and test it.
- 7.1.11 The Contractor’s attention is drawn to the requirements of Sub-Clause 2.3.1 of this ERT. Also, the doors shall be designed and tested that when normally installed, one leaf can sustain a concentrated load of 900 N applied to the plane of the door, at the center of the front edge, with a maximum deflection of not more than 6 mm, but with no permanent deformation; and shall not exceed a force of 250 N when closing.
- 7.1.12 The door operating system at each doorway shall be capable of being isolated electrically and mechanically. When isolated, the doors shall be kept closed by mechanical means. The door operating system shall include damping, to smoothly arrest door leaf motion, at the end of the open and close stroke.
- 7.1.13 All doors shall open and close simultaneously. Doors shall fully open within 2.0 to 2.5 s of the door open command, and shall fully close and lock within 2.5 to 3.0 s of the door close command. During normal door operation, the maximum velocity of each door leaf shall not exceed 1.5 m/s. When closed, all passenger side entrance doors shall be automatically mechanically locked in the fully closed position, preventing the doors being opened beyond a limited push back facility. When closing, the force shall not exceed 250 N.

- 7.1.14 The doors shall be manufactured from the same material used in the construction of the car body shell, with a honeycomb core or equivalent, and shall incorporate the same exterior finish. All joints shall be sealed against moisture ingress, and drain holes shall be provided in the bottom of the doors to allow the escape of condensation, water from rain or as a result from cleaning the car. Internal metal reinforcement shall be provided for the attachment of door hardware. The doors shall be appropriately insulated to meet the noise requirements. Each door leaf shall be equipped with a full-length male/female rubber nosing, which shall provide a weather tight seal, be capable of withstanding the rigors of service, and prevent injury to passengers trapped between closing doors.
- 7.1.15 The bottom of the doors shall be provided with stainless steel kicking plates and with easily replaceable door guides, which shall be adjustable in the vertical direction, and shall be manufactured from a wear-resistant, low friction material such as high-density high molecular weight polyethylene.
- 7.1.16 The doors shall be glazed with a fixed glazed window of toughened glass to current railway transport standards. The glass tinting shall be according to Sub-Clause 5.11 - Windows and Glazing. The window assembly shall be free from rattles, and the mounting shall be capable of withstanding the pressure differentials associated with head-on pressure, passing trains, prevailing winds, etc.
- 7.1.17 All door mounting hardware and door actuation hardware must be readily accessible for adjustment and removal through the aforementioned access panels. A door leaf shall be capable of being removed and replaced within 60 minutes.
- 7.1.18 One set of passenger side entrance door production hardware (door leaves, operators, local control units, etc.) shall be subjected to an accelerated life cycle test, whereby the doors are installed in a simulated door frame and operated for a minimum of 1.5 million cycles. This test shall be completed before the first car is ready for shipping, and must ensure that the specified reliability is met.
- 7.1.19 A door for gangway shall be provided at each end of each vehicle. A door for gangway shall have heat and fire -resistant tempered glass and structure and function to prevent scattering at breakage shall be applied. It shall be used stainless steel for the rim and applied a collision prevention film to the glass surface. The gangway shall be a self-closing type with a normally closed structure, but a sliding door on one side shall be a mechanism that can hold the door and can easily solve it or normally closed structure. The gangway shall be able to maintain and continue constant braking force during opening and closing operation and shall be robust. The width of gangway shall be more than 900mm. The gangway specification shall be submitted to the Engineer for review and comments.

7.2 Cab Doors

- 7.2.1 A sliding or both side open type hinged door shall be provided in between the driver’s cab and the passenger saloon to allow ingress/egress of the train crew.
- 7.2.2 In addition, a hinged door or sliding door shall also be provided on both sides of the driver’s cab to allow direct ingress/egress of drivers to and from the station platform and at the depot. The side door shall contain a vertical sliding window. The side door shall open inwards only if hinged door is provided.
- 7.2.3 The side door shall be manufactured from the same material used in the construction of the car body shell and shall incorporate the same exterior finish.

- 7.2.4 The cab door from the passenger saloon and the side doors shall be able to be locked manually using the same key. Similarly, these doors shall be able to be locked and unlocked from inside the driver’s cab without a key.
- 7.2.5 The side door lock shall be accessible from both ground level and platform level. The door design shall be submitted to the Engineer for review.

7.3 Passenger Door, Operators and Controls

- 7.3.1 Passenger door operators shall be service-proven in tropical condition and in similar environment to that of the Manila area.
- 7.3.2 There shall be local audible and visual indications to passengers (to be submitted by the Contractor for the Engineer’s review), during the door release sequence as well as prior to and during the door closing sequence, and there shall be a delay of 1 second prior to opening or closing the doors.
- 7.3.3 No part of any door, door installation, door control system or any other components for use within the door systems, shall be capable of causing injury to passengers or personnel as a result of door operation. Particular attention shall be paid to trapped obstacles in the passenger doors.
- 7.3.4 No spurious electrical signals shall cause any door to be released or opened unintentionally, particularly when the train is in motion.
- 7.3.5 All saloon doors shall be provided with interlock switches incorporated in the door control circuit to prove that doors are closed and locked. When the door control circuit is not proven closed, train movement shall be inhibited and brake shall remain apply. Saloon door interlock status shall then be interfaced to the TMS.
- 7.3.6 The body side doors are equipped with the following safety system:
 - a. Passengers are informed that the doors are being closed by sound and visual devices;
 - b. Starting of the train can only be authorized when all doors are closed and locked; and
 - c. That a door is prevented from closing when a passenger or object is located between the two closing door leaves and after attempting to close, that particular door will reopen and attempt to close again repeatedly until the object is cleared and the door can close and lock.
- 7.3.7 Detection of small objects, hands, clothes shall be detected by sensitive edge door devices. The obstruction detection shall be tested with a rigid 15 mm diameter object placed perpendicular to the door panels at any three (3) vertical locations along the leading edge of the doors (except the lowest 75 mm and the upper most 100 mm).
- 7.3.8 On detection of an obstruction the doors shall behave in the following manner (or similar):
 - a. If, during the first attempt to close, a door is obstructed, the door shall reopen by at least 100 mm for each leaf and remain open for 1 second before attempting to close again. The driver shall be notified of the door obstruction and its location by the TMS;
 - b. If, on the second attempt to close, the door is obstructed, the door shall reopen by at least 100 mm for each leaf before attempting to close again. There shall be the ability to manually push the door back further;
 - c. If, on the third attempt to close, the door is obstructed, the door shall open to full width and remain in this state until reset; and
 - d. To reset the door, the crew shall operate the door close control to restart the closing cycle.

- 7.3.9 The push-back feature shall be operative after the door leaves have been locked. It shall be possible to manually push back each closed door leaf to enable entrapped objects such as clothing and other articles, to be withdrawn, even after the mechanical lock has engaged. The force required to push back each door leaf shall not be less than 80 N more than 120 N.
- 7.3.10 The door system shall continue to operate correctly within the defined car battery voltage range.
- 7.3.11 The above gaps and timings are notional, and shall be capable of being adjusted after experience in service has been gained. The initial settings shall be determined from an investigatory trial undertaken using the door test rig.
- 7.3.12 Time delay of door motion shall be adjustable from 0 to 3 seconds.
- 7.3.13 Door warning shall be clearly audible to both internally and externally to the cars at all door passenger portals.
- 7.3.14 The volume of door warning tones shall be adjustable by maintenance staff only. The opening and closing of doors shall only be possible from an operative cab, and it shall not be possible to energize the door open circuits if train speed is greater than 3 km/h. Door closing or opening time shall be adjustable between two and five seconds.
- 7.3.15 Propulsion power shall be inhibited until all doors have closed and are locked; the Contractor shall provide the function that does not enable brake release and train start if all doors are not closed and locked.
- 7.3.16 It shall be possible to isolate a defective door on any car from the door open command, at which time the yellow fault lights on that side of the exterior of the car shall illuminate. The isolated door(s) of a car(s) shall be identified in the TMS and marked “X” to denote it has been isolated.
- 7.3.17 The driver must reset the device before the train can proceed. The device shall be recessed and suitably sealed to prevent accidental actuation.

7.4 Emergency Door Release Mechanism

- 7.4.1 All passenger doors shall be equipped with an emergency door release mechanism to allow passengers to manually open the door without the use of special keys or tools.
- 7.4.2 The manual emergency release shall however be shielded from unintentional use by passengers, whilst still being available in an emergency.
- 7.4.3 In the event of activation of the emergency door release mechanism, warning message and audible signal shall be displayed on the TMS HMI to alert the driver. The driver shall have 5 seconds (time period shall be able to be adjusted from 0 to 10 seconds) to acknowledge the event. If the driver fails to react within the time period, the emergency brake shall be applied.
- 7.4.4 Upon activation of the emergency door release mechanism, the door shall not be allowed to be manually opened with the train speed higher than 5 km/h.
- 7.4.5 Clear and unambiguous signage in both Tagalog and English giving instructions on the use of passenger door emergency facility shall be provided.

7.5 Door Isolation and Access – Interior/Exterior

- 7.5.1 The power supply to an individual doorway can be switched-off/isolated whereby the door is permanently closed and locked out-of-use.
- 7.5.2 Access through the left and right passenger doors nearest the driver’s cab shall be able to be opened from the outside by a key.

7.6 Door Interfaces

- 7.6.1 The Contractor shall consider in their design the following interface requirements:
- a. TMS / Status monitoring;
 - b. Chime; and
 - c. Light.
 - d. Signaling system; and
 - e. PSD Controller.
- 7.6.2 Doors shall be part of the safety loop and shall be interlocked with the brake system.

7.7 Door Opening Authorization in Degraded Operation

- 7.7.1 In case of unavailability/failure of door authorization signal from Signaling system, adequate safeguards shall be provided and also incorporated in control circuit to minimize the probability of error of opening of doors on wrong side (other than platform side) during revenue service.
- 7.7.2 In this case, the opening can be controlled by the train driver by the action on a right opening button or a left opening button placed on the desk.

7.8 Interlocks related to PSD (Platform Screen Door)

- 7.8.1 Door control units shall be interfaced with PSD controller to get data or signals of PSD such as platform side, stop position, state of the PSD (open/close/trouble) etc.
- 7.8.2 Interlocks for door control shall be ensured to be accomplished by using above. Also, interlock for propulsion, which shall not allow the train to move if train cannot start safe, shall be ensured to be accomplished. Rolling Stock Contractor shall be coordinated with related Contractor (CP NS-01) to develop interlocks for the best possible safety above.
- 7.8.3 Though above interface and circuits shall be completed for preparation, interlocks shall be changeable valid or invalid easily.
- 7.8.4 PSD control circuits shall be interfaced with TMS for recording events and indicating necessary information of PSD.
- 7.8.5 This system shall have the redundancy and the below function in case of any trouble.
- 7.8.6 Forcibly doors open function:
In case of no door enables, the doors can be opened. And if this function is activated, the status shall be interfaced to PSD Controller, Space Radio and TMS.
- 7.8.7 Forcibly train acceleration enable:
In case of PSD trouble, train can accelerate by using this function. And if this function is activated, the status shall be interfaced to Space Radio and TMS.
- 7.8.8 Forcibly changing function whether PSD interlock function is activated or not.
- 7.8.9 In case interlocks are not necessary, all interlocks related to PSD shall be invalid when this function are activated.
- 7.8.10 Details of interlocks related to PSD shall be submitted for review and comments by the Engineer.
- 7.8.11 The above-mentioned specifications shall be available for interface with the installation of PSD.

8 Ventilation and Air-Conditioning

8.1 General

- 8.1.1 Each car shall be provided with two units of ventilation and air-conditioning (VAC) system complete with relative humidity control. The air-conditioning units (ACU) shall be controlled independently such that if there is a failure in one unit, the other units shall continue to operate normally. All system components must be service-proven, and must be tested to demonstrate compliance with the requirements of this ERT.
- 8.1.2 The Contractor shall submit a complete design of the air handling and diffusing system along with air flow and velocity calculation for the Engineer to review. Upon installation on the car, the complete air supply/diffusing system shall be measured and balanced and the air flow and velocity confirmed. Air-balancing on each car shall be performed by a qualified VAC technician. Measurements shall be conducted in accordance with American Society of Heating, Refrigerating and Air-Conditioning Engineers (ASHRAE) requirements or equivalent.
- 8.1.3 The Contractor shall provide test and service equipment necessary for the maintenance and repair of the VAC units. This shall include but not be limited to an off-board test bench, refrigerant recovery/recycling equipment and portable vacuum pump.
- 8.1.4 In order to cater for an unexpected stoppage of the VAC system, there shall be a reset breaker installed in the driver’s cab.

8.2 Ventilation System

- 8.2.1 Blower fans supplied as part of the overhead evaporator units shall be capable of providing car ventilation. Fresh air shall enter the car through screened openings in the roof on each side, pass through stainless steel ducts (sloped downwards to drain), and pass through a filter into a plenum chamber adjacent to each overhead evaporator unit. The design shall prevent blown rain from entering the plenum and leaking into the car interior.
- 8.2.2 Re-circulated air shall be drawn through grills in the ceiling and mix with the fresh air. This air mixture shall then pass through another filter into the evaporator unit, from where the blower shall force the air through the evaporator coils into the main air ducts. The ventilation system shall ensure that the inside pressure be positive value with all doors and windows closed with a pressure range of 20 to 40 N/m².
- 8.2.3 Means shall be provided to adjust the volumes of fresh and re-circulated air. A minimum of 2,500 m³/h of fresh air per car shall be provided.
- 8.2.4 The main air distribution duct shall be manufactured from anodized aluminum or service-proven material, and shall be constructed to ensure that the exiting air velocity is constant along its length.
- 8.2.5 Air filters shall be washable/re-useable and shall be well supported to prevent passing air from dislodging them should the filters become blocked; they shall seal well at all edges. The filters shall be easily replaced and shall be sized such that they shall be serviced monthly.
- 8.2.6 In order to reduce the frequency of maintenance of the filter, roll filter shall be used. The roll filter is furnace material wound around the core, and when the set time has elapsed, a new furnace material portion is automatically set. Setting time of the winding is able to be changed arbitrarily by maintenance people. The length of the roll filter shall be reviewed by the Engineer.
- 8.2.7 Furthermore, each air-conditioning unit shall incorporate a mechanical ventilation system. Alternatively dedicated type shall also be considered. This ventilation system shall provide fresh air ventilation to the cars which will be supplied by the battery in the absence of catenary power (1,500V dc).
- 8.2.8 The entire ventilation system shall be submitted to the Engineer for review.

8.3 Cooling System

- 8.3.1 The VAC shall be thermostatically controlled and shall be service-proven and shall automatically maintain the specified interior temperature conditions. Relative humidity in the car shall not exceed 60% under stabilized conditions. The capacity of the VAC shall be calculated considering the maximum number of passengers due to demand forecasts. The calculated capacity could be about 98,000 kcal/h/car but this would depend on the ability to maintain temperature and humidity levels with prescribed limits. The outside units of VAC shall be mounted on the roof of the car into two separate units.
- 8.3.2 In order to lower the center of gravity, the weight of one outside unit shall be as light as possible. The Contractor shall, for example use aluminum or any equivalent material that is rust-resistant and selecting the most adequate compressor, etc.
- 8.3.3 Air flow over the evaporator coils shall be no more than 2.5 m/s. Evaporator coils shall preferably be manufactured from copper, and shall have copper fins; however, aluminum elements are also acceptable provided they are sufficiently protected from the elements. A condensate pan shall be provided beneath the evaporator coil. The pan shall be made from stainless steel with suitable drain lines and shall be easily removed for cleaning. The condensate drain lines shall be insulated to prevent condensation.
- 8.3.4 The refrigerant used shall be environmentally friendly such as R407C or equivalent; the use of refrigerant containing fluorocarbons shall not be allowed. To avoid issues of moisture and water, connectors in outside units shall be waterproof.
- 8.3.5 The evaporator unit shall include all required components, such as the liquid line, solenoid valve, modulating solenoid valve, thermal expansion valves, liquid line strainer, liquid line sight glass/moisture indicator, etc. Appropriate gauge ports to aid troubleshooting shall be provided.
- 8.3.6 Blowers shall be direct-driven by a motor, which shall be powered by the 440 V ac auxiliary power supply system.
- 8.3.7 The compressor-condenser unit shall be heavy duty transportation grade, service-proven combined hermetic compressor/condensing unit. The compressor motor shall be powered by the 440 V ac auxiliary power supply system. Cylinder unloaders shall be easily adjusted, and shall provide stages of unloading.
- 8.3.8 Sequential starting of compressors on a train shall be provided. Condenser coils shall preferably be manufactured from copper, and shall have copper fins; however, aluminum elements suitably protected from the environment are also acceptable. The coil shall be designed with adequate capacity to provide a condensing temperature no greater than 16 °C above the condenser cooling air temperature, under full rated load conditions.
- 8.3.9 VAC units shall be easily removed by lifting without the need to break any connections in the refrigeration circuit.
- 8.3.10 The VAC units shall be capable of cooling down an empty car, which has stabilized throughout the surface design temperature without sun radiation, to the control temperature of 25 °C in the passenger saloon within 30 minutes.
- 8.3.11 Full details of the entire VAC system shall be submitted for review by the Engineer.

8.4 Operation and Control

8.4.1 Operation

- 8.4.1.1 The VAC system shall automatically maintain the interior temperature of the car (including the driver’s cab) at the setting temperature to the controller with any exterior ambient temperature ranging from 20 °C to 40 °C.
- 8.4.1.2 If the exterior ambient temperature is above 40 °C, the interior temperature shall be maintained at 15 °C below the exterior ambient. Temperature overshoot shall be limited to 1 °C.
- 8.4.1.3 These temperatures must be maintained with or without the heat loads from the various sources, human, equipment and solar gain. Relative humidity shall be maintained at not more than 60%.

8.4.2 Controls/Testing

- 8.4.2.1 Standard programmable logic controller of industrial grade shall be provided for the control and monitoring of the VAC system. Temperature sensors shall be located to ensure that they are not unduly affected by local sources of heat, such as motors, and shall be readily accessible for maintenance and replacement. The settable interior temperature to the controller shall be from 18 °C to 30 °C. The setting-temperature of each car shall be able to be temporarily changed by the maintainer, by operating the TMS monitor in the driver’s cab. The temporary changed setting temperature shall be password protected and shall revert to the original setting-temperature when the power supply of the controller is turned off and on once.
- 8.4.2.2 The temperature control unit shall be interfaced with the TMS and shall incorporate local LED display, indicating the status of the temperature control functions. The unit shall also indicate the fresh air temperature and the return air temperature, etc. Indicators shall also be provided to verify normal operation.
- 8.4.2.3 The equipment shall also include an embedded fault indication and fault diagnostic system, and shall be connected to the TMS. A portable test unit (PTU)/PC, including the necessary interface programs, shall also be provided to isolate temperature control problems and allow downloading and analysis of recorded faults. The VAC system shall operate with moderately reduced power when it receives signal from TMS that APSE stops to operate.
- 8.4.2.4 Control of the VAC shall be operated via the TMS monitor in the Cab. The operating state of VAC and the passenger room temperature, etc. shall be displayed in the TMS monitor.

9 Brake System

9.1 General

- 9.1.1 The trains shall be supplied with brake equipment and functions specified herein, such that a complete, fully integrated and fully functioning friction brake/electric braking system is provided. In addition, all equipment shall be specified in conjunction with the provision of Sub-Clause 3.7 - Bogie Mounted Brake Equipment and Sub-Clause 10 - Pneumatic Equipment of this ERT. All equipment shall be supplied by an experienced braking equipment manufacturer with documented proven satisfactory experience with similar equipment to that specified herein.
- 9.1.2 Braking actions shall be controlled by the master controller in the driver’s cab. including the service and emergency brakes. The Emergency system shall be fail-safe (energize to release). Emergency braking shall be friction only, protected by the wheel slide protection system, but shall not be jerk limited. Propulsion power shall be inhibited when braking in any levels. The propulsion circuit line breaker (LB) shall be opened when the emergency brake is commanded.
- 9.1.3 The braking equipment shall be tested to demonstrate compliance with the requirements of this ERT. The Contractor shall perform tests to confirm specified train deceleration from various speeds in all braking modes, including emergency brake and friction brake only (degraded cars).
- 9.1.4 Another emergency braking system in addition to the above shall be equipped. This braking system is called a security braking system. The security braking system shall be operated under the same conditions as the emergency braking system and it shall be enabled with a simple switch. The role of security braking system is a backup braking system in case the emergency braking system does not operate properly. The security braking system, supplied from the dedicated air tank to a pneumatic action device shall have a function that is totally independent from the service and emergency braking system. The security braking system shall not be linked with the variable loading of the train but shall be supplied with a dedicated air tank with sufficient capacity and a check valve.
- 9.1.5 The braking system shall satisfy the following deceleration under any conditions (incidentally, the deceleration referred to here means the instantaneous deceleration at any velocity.) e.g., considering the decrease of deceleration due to rain, the core braking system shall control the proper torque corresponding to the load; however, the security braking torque shall be same as emergency braking torque at W0 because the security braking system is not linked with the load.
- a. Service brake deceleration shall be 4.2 km/h/s;
 - b. Emergency brake deceleration shall be 4.7 km/h/s; and
 - c. These decelerations shall be defined as ‘design deceleration’ and shall not be used by calculation within the on-board signaling system.
- 9.1.6 Additionally, as soon as the regenerative braking torque is varied, including revocation of regenerative brake, the friction braking torque shall be supplemented. But, in very short time up to being supplemented, the instantaneously deceleration may be reduced and braking distance may be extended. In addition, in rainy condition the reduction of friction brake deceleration is usually a little larger than that of the regenerative brake. So considering these, the deceleration of friction braking shall be a little higher than that of regenerative braking under normal condition.

- 9.1.7 For the service brake, the loaded braking ratio must be 70% or more. For the security brake, the empty car brake ratio must be 70% or more. The Rolling Stock shall comply with all relevant requirements in Japanese Ministerial Ordinance, MLIT Chapter 8, Article 69 (Brake unit related) or other equivalent standards.
- 9.1.8 The braking system shall be designed to be able to interface with PSD system and provision to be interface with ATO system.
- 9.1.9 In addition to the above, the remaining of regenerative and pneumatic shall be finally adjusted considering Automatic station stop accuracy. Interface between BCU and ATO particularly for service brake step (via TMS control transmission) shall be at least 31 steps.

9.2 Friction Brakes

- 9.2.1 The Contractor shall design the friction braking system using tread brakes to accompany the electrical braking and provide all the service and emergency braking to meet the deceleration requirements, the friction braking system design shall be provided to the Engineer for review.
- 9.2.2 The friction brake shall be fully capable of performing all braking duties, without the assistance of the electric brakes. The brake material shall not contain any asbestos or other equivalent health concerning materials, and the Contractor shall provide the Engineer with full details of the material composition to allow health hazards assessment.
- 9.2.3 The Rolling Stock shall be equipped with parking brakes. The parking brake shall incorporate a spring-applied function achieved through air release brake actuators, and must be capable of holding an 8-cars train in W3 loading condition on a 3.5% grade.
- 9.2.4 By design, as air pressure is released from the brake cylinders, the spring brakes shall apply. Should air pressure not be available, the driver may release the brakes electro-mechanically from the cab by pressing a switch. This action shall actuate an electrical solenoid which shall apply pressure to the brake cylinder release lever. The brakes may also be released manually by actuating a lever on both sides of each bogie. The system shall automatically reset upon reapplication of main reservoir air pressure.
- 9.2.5 Suitable slack adjuster shall be provided for the brake cylinders. It shall be possible to isolate the friction brake system individually in each car. The Contractor shall carry out a performance test of the friction brake and submit the result to the Engineer.

9.3 Electric Brakes

- 9.3.1 Regenerative braking shall be supplied, with the priority being given to regenerative braking over mechanical braking. The electric brake shall have the capacity to produce all service braking effort and shall be fully effective down to 0.5~1km/h. Regeneration shall be inhibited when the catenary voltage is above 1,850 V dc or below 900 V dc.
- 9.3.2 Performance of the regenerative brake shall achieve at least the following:
 - a. Under condition of catenary voltage:1650 V dc, load: 20 t per vehicle and velocity: 0~80 km/h, regenerative braking capability (including trailer car’s brake torque) is the brake torque corresponding to deceleration 3 km/h/s;
 - b. Under condition of catenary voltage:1650 V dc, load: 20 t per vehicle and velocity: 0~64 km/h, regenerative braking capability (including trailer car’s brake torque) shall be equivalent to deceleration of 3.7 km/h/s;
 - c. Under condition of catenary voltage:1650 V dc, load: 0 t per vehicle and velocity: 0~84 km/h, regenerative braking capability (including trailer car’s brake torque) shall be equivalent to deceleration of 4.2 km/h/s; and

- d. Under condition of catenary voltage:1650 V dc, load: 0 t per vehicle and velocity: 0~99 km/h, regenerative braking capability (including trailer car’s brake torque) shall be equivalent to deceleration of 3.0 km/h/s.
- 9.3.3 Furthermore, the Contractor shall endeavor to achieve higher regenerative performance and propose the specification to be reviewed by the Engineer.
- 9.3.4 Regenerative performance for ATO recovery mode is acceptable. The contractor shall refer to Sub- Clause 11 for details.

9.4 Wheel Slide Control System

- 9.4.1 Trailer cars shall be equipped with a wheel slide detection system to maximize the utilization of available wheel/rail adhesion under low adhesion conditions, to eliminate damage and unnecessary wear to wheel treads. In the trailer cars, slide shall be detected on a per axle basis and commensurate protection also shall be provided on this basis.
- 9.4.2 The hardware and software which is mounted in each trailer car shall reliably detect all wheel-slide conditions that may occur on any axle in that trailer car, and shall initiate actions that minimize or terminate these conditions, whether they occur randomly or synchronously.
- 9.4.3 The system shall compensate for wheel size differences. The detection of axle speed differences up to 3 km/h shall initiate the required reduction of braking effort to eliminate this speed difference.
- 9.4.4 During friction braking, brake cylinder pressure shall be modulated in proportion to the axle speed differential, assisted by rapid pressure reduction (dump) valves when differentials or accelerations are large. In emergency braking, the dump valves shall be used.
- 9.4.5 The system shall incorporate monitoring features to detect both failure of sensor inputs, and system performance indicative of failure of that function. Detection of sensor or system malfunction shall disable the system so as to guarantee braking. All faults shall be logged in the train’s TMS.
- 9.4.6 The wheel slide control system shall operate normally with the speed sensor.
- 9.4.7 The wheel slide control system shall not allow the axle speed differential to be over 5 km/h. The operation of the sliding control shall be based on the operation at about 3 to 5 km/h with the aim of re-adhesion within 1 km/h. The following performance shall be achieved:
 - a. Digital wheel slide protection with gradual slide correction shall be provided in all braking modes. The slide detection in a trailer car shall be performed per axle and the correction per axle. The correction of slide shall operate independently on each car;
 - b. The sliding effect shall be maintained during a relevant period of time, in order to increase the available adhesion at the wheel-rail contact with permanent control, in minimizing the air consumption and optimizing stopping distance;
 - c. The Contractor shall demonstrate that the correction process for wheel slide shall not cause infringements of the signalling compatibility requirements;
 - d. The performance of the wheel slide protection equipment shall satisfy the relevant requirements of Japanese Technical Standards and Guidelines for Railway and testing shall be carried out in accordance with Section 2 of the UIC 541- 05 or equivalent;
 - e. The wheel slide system shall detect the onset of slide by either an axle deceleration exceeding a pre-set parameter, or detection of a difference between the relative speeds of the axles of any one axle of any bogie;
 - f. The Contractor shall incorporate the complete compatibility for slide with the signalling scheme and interfaces. The Contractor shall submit full details of the wheel slide

protection scheme and equipment; and

- g. Wheel slide indication shall be made available in the driving cab through the TMS system.

9.4.8 The complete wheel slide control system shall be reviewed by the Engineer.

9.5 Brake Control/Brake Blending

9.5.1 The brake control/brake blending system shall be a service-proven system.

9.5.2 The braking force control in the car shall be performed by comparing the required brake amount with the actual brake amount, etc. via working of the PECE, BCU and TMS.

9.5.3 By using this function, the opportunity presents itself to utilize energy saving regenerative braking coupled with minimal brake-pad wear.

9.5.4 When the regenerative braking force is insufficient with respect to the required braking force, the trailer car’s friction brakes shall be initiated. If the braking torque is still insufficient, the motor car’s friction brakes shall be initiated.

9.5.5 If a shortage of friction braking torque occurs in one car, this shall be compensated by other cars contributing to the overall brake torque for the entire train.

9.5.6 In case of complete electrical braking failure, brake control shall allow instantaneous substitution of friction braking without loss of braking power.

9.5.7 When the electrical brake switch is off and any other electrical brake effectiveness condition is not satisfied the braking system shall be exclusively friction braking only.

9.5.8 The various braking mechanisms work together in a balanced way to optimize deceleration, ride comfort, jerk and these systems will be set up during commissioning.

9.6 (Not Used)

9.7 Brake Control Unit (BCU)

9.7.1 The brake of each car shall be controlled by the brake control unit (BCU) performing the following functions:

- a. On receipt of a brake demand from the control transmission of the TMS, the service brake shall be applied at the correct and corresponding level having regard to the car weight (from information provided by the pneumatic suspension system);
- b. When a change in braking effort is demanded, the control system shall control the rate of change to be in accordance with the specified levels of jerk and response times;
- c. Any shortfall in the effort provided by the electrical brake shall be achieved using the friction brake. Service proven design in accordance with international standards may be submitted for Engineer review;
- d. The BCU shall contain fault diagnostic facilities, which records all the relevant fault information and status of the equipment at the instant of failure to facilitate maintenance;
- e. The fault diagnosis function shall be compatible with the TMS to enable fault log information to be accessed through the TMS. A comprehensive set of indications shall be available on the BCU to display major faults. The fault indications shall be electrically latched when the faults are detected and shall illuminate whenever the supply to the electronics is switched on. The information contained within the fault log shall be stored on non-volatile memory;
- f. In case of a brake shortage during braking by the ATP, the car in which the brake shortage

- happens shall be assisted with the emergency brake. Also in case of brake seizure, the braking system shall be equipped with the function to forcibly to release the brake by remote operation from the cab;
- g. In case of some brake troubles which have possibilities to cause other troubles for example wheel damaging, acceleration command shall be cut off. However, in this function, a short circuit switch shall be supplied;
 - h. The friction brake at zero speed shall be coordinated with the door control system. When all the doors are not closed, the BCU shall not release the brake;
 - i. When the braking torque of the train-set is insufficient due to a breakdown of any BCU, the required braking torque of the train-set shall be ensured by the train-set brake torque control function of the TMS;
 - j. When a brake seized occurs on a certain bogie, the brake on that bogie shall be able to be remotely released from the driver’s cab. The remote brake release action shall not affect the subsequent braking performance; and
 - k. Gradient starting brake function to prevent roll-back shall be equipped.
- 9.7.2 The associated brake unit shall contain all the pneumatic items necessary to control all applications of the friction service brakes and emergency brakes on that car. The emergency brake control valves independent of the service brake control valves shall be controlled directly from the emergency brake train control lines. The friction emergency brake shall be fail safe and of an "energize to release" type.
- 9.7.3 The emergency brake loop shall be a high integrity fail safe hard wired circuit and shall in no way be allowed to be bypassed due to an error in operation.
- 9.7.4 The mechanism of brake force/car weight adjustment employed shall ensure a full proportional adjustment is achieved through the braking range between tare loading (W0) and loading conditions (W3).
- 9.7.5 The method by which the passenger load-sensing signal is processed shall be arranged to ensure that absence of the signal, for any reason, shall result in a brake force being applied corresponding to a dynamic (W4) loading condition on that car.

10 Pneumatic Equipment

10.1 General

- 10.1.1 The train shall be supplied with the equipment and functions specified herein, such that a complete, fully integrated and fully functioning friction brake and pneumatic system is provided.
- 10.1.2 A complete pneumatic system shall be maintained, which shall consist of the air compressor assembly and all associated piping, reservoirs, fittings, etc., to provide a fully functional system capable of supplying all air requirements for the friction braking system, air suspension system, horns, etc. for the complete trainset.
- 10.1.3 Compressed air shall be sufficiently filtered and dried prior to entering the pneumatic lines. All feeds from the main supply line shall be protected by check valves to prevent the rapid loss of air should a rupture or leakage in the line occur. Flexible connections from the air compressor to the main supply line shall be likewise protected by check valves. Suitable automatic drain valve and manual drain valve shall be fitted.
- 10.1.4 The pneumatic equipment, including the compressor shall have a maximum operating pressure of 10 bars. The compressor shall be adequately protected, including from an over pressure situation.

10.2 Air Compressor Assembly

- 10.2.1 The Rolling Stock shall be equipped with a pneumatic system consisting of service-proven air compressor assemblies, with air compressor units directly driven by electric motors, air filtration and a twin tower air drier equipment, inter cooler, safety valves, etc. The assembly shall be installed under the car via resilient mounts, and care shall be taken to minimize the amount of noise and vibration transmitted into the car body structure and to the wayside.
- 10.2.2 The air compressor motor shall be powered from the Auxiliary Power Supply (APS) system.
- 10.2.3 The design of the pneumatic system shall be capable of supplying all of the air requirements for a train consist in the event of failure of one compressor unit.
- 10.2.4 The capacity of air compressors shall be sufficient for the simultaneous operation of all pneumatic devices. Calculations for the capacity of the air compressors shall be submitted for review by the Engineer.

10.3 Pneumatic System

- 10.3.1 Stainless steel piping or thick-walled copper tubes shall be used throughout the cars, unless otherwise specified, subject to review by the Engineer. Joints shall be made using rail industry approved compression fittings. Joints shall not be made to connect straight runs of pipe work, unless otherwise specified, subject to review by the Engineer. Inaccessible runs of pipe work shall not utilize joints. All piping shall be installed to keep fittings to an absolute minimum.
- 10.3.2 Cut-out cock handles shall be installed so that in the open position they are parallel to the flow of air, and in the closed position they are perpendicular to the flow of air. Cut-out cock handles shall be readily accessible for use in an emergency. All cut-out cocks shall be of the vented type, unless the function prohibits their use. The function of all cut-out cocks shall be clearly identified by means of engraved stainless steel plates riveted to the structure adjacent to the valve, the lettering on which shall be filled with black epoxy paint and suitable color coded.

- 10.3.3 All pneumatic tanks or reservoirs shall have drain cocks to remove condensation. Separate systems within the pneumatic system shall be supplied via a vented cut-out cock and a strainer, and shall be provided with separate air reservoirs, supplied through a check valve to protect against the sudden loss of air pressure. The air brake reservoir shall be sized to provide at least three emergency brake operations under W3 loading conditions. Reservoirs shall be tilted to assist moisture collection, and shall include automatic/manual drain valves.
- 10.3.4 The main air reservoir shall have sufficient capacity for the simultaneous operation of all pneumatic devices. Calculations for the capacity of all reservoirs shall be submitted for review by the Engineer.
- 10.3.5 All flexible hoses shall be date stamped, and their full life indicated. All flexible hose connections on removable assemblies shall be of railway service proven standard and quick-connect coupling.
- 10.3.6 The device and air pipe from the last tank as the source of the braking force to brake cylinder used to service brake and emergency brake shall be placed within the width of bogie.
- 10.3.7 The device and air pipe from the last tank as the source of the braking force to brake cylinder used to security brake shall be placed within the width of bogie frame.
- 10.3.8 A cut-off valve shall be provided at a place required for maintenance or abnormality.

11 Propulsion System

11.1 General

11.1.1 A modern and well service-proven three-phase alternating current propulsion system shall be provided for 4 cars of all 8 cars and shall have the following features:

- a. Four DC to AC inverter packages (self-cooling power conversion equipment), one in each motor car powering the sixteen (2 per motor bogie) traction motors in a car. For the purpose of the energy conservation improvement and low center of gravity, the material of the filter reactor shall be copper; or other service-proven material, subject to review by the Engineer.
- b. The propulsion equipment shall be cooled by external heat exchangers without the requirement of air filters;
- c. A car level microprocessor-based control system (power electronics control equipment), which shall perform all propulsion of acceleration and regenerative braking;
- d. The magnetic flux caused by filter inductor shall be less than 1mT at 1.0 m of the just above of filter inductor from the floor level;
- e. Each AC squirrel cage traction motor shall drive a gear unit. Traction motor insulation shall be tropicalized and shall be Class 200 insulation or better; and
- f. In the event of propulsion failure occurs on any car, that propulsion unit shall be automatically disabled (or by manual disable from the driver’s cab) to allow the train set to be operated by the rest of the healthy propulsion units.
- g. About the blending between friction brake and regenerative brake when brake starts, the dummy signal of regenerative brake shall be short as possible considering ride effort. In case catenary voltage is higher than the voltage which regenerative brake is effective, the dummy signal of regenerative brake shall not be used.
- h. Lowered regenerative performance applied except for ATO normal mode may be acceptable in case it is difficult to achieve reasonable design in consideration with capacity and size, weight and so on. It shall be necessary to be reviewed by the Engineer when above performance will be adopted.
- i. Wheel diameter correcting shall be made to this device.

11.1.2 The performance of acceleration shall not be less than the following statement. In the following conditions, the propulsion system shall have sufficient capacity for normal and recovery operation. The CP NS-02 Contractor shall validate and confirm the normal and recovery run (power consumption) curves submitted by CP NS-01 Contractors. The Contractor shall simulate acceleration power consumption, regenerative power amount, RMS current, maximum drawn current during acceleration, maximum return current during regenerative braking to OCS and the temperature rise of each equipment etc. Total power consumption of a round trip (Clark-Calamba) for the following minimum conditions shall be submitted for review by the Engineer:

- a. Load condition: W3 loading and 20 t/car (round trip);
- b. Wheel diameter: 820 mm;
- c. In case of recovery (catch up) operation (ATO all out condition);
- d. Self-cooling system;
- e. The maximum operational speed limit in the main line is 120 km/h;
- f. Operational headway is 6-minutes (subject to simulation of final service pattern);
- g. The dwell time at each station is 30 seconds;
- h. The dwell time at end stations is 180 seconds (subject to simulation of final service

pattern);

- i. Indicative journey time for the round trip including 37 station dwells for both directions plus end change dwell is 266 minutes and 59 seconds, at a commercial average speed of 63.46 km/h (subject to simulation of final service pattern);
- j. When 25% loss of the on-board traction motors total power, train can run all day;
- k. (with restriction on regenerative brake at a load above a certain load)
- l. When 50% loss of the on-board traction motors total power, train can run 1 round trip; (with restriction on regenerative brake)
- m. Catenary voltage: 1350 V (acceleration), 1650 V (regenerative);
- n. Acceleration use by simulation: the maximum performance;
- o. Deceleration used by simulation is 3.0 km/h/s/ ;
- p. Unladen mass: to be calculated by Bidder is 270 t;
- q. Start resistance: to be calculated by the Bidder;
- r. Inertial mass: 10% of unladen mass (motor car), 5% of unloaded mass (trailer car);
- s. Running resistance;
$$R = (1.65+0.0247V)*m_M + (0.78+0.0028V)*m_T + 9.81*\{0.028+0.0078*(n-1)\}*V^2$$

Where, R : Running resistance [N]
V : Train speed [km/h]
 m_M : Total load of motor-cars included in tare weight and passenger load [kN]
 m_T : Total load of trailer-cars included in tare weight and passenger load [kN]
n : Total number of cars per train-set
- t. Gear ratio: 6.53 (98/15);
- u. It is possible to push a failed train set with the same load; and
- v. Propulsion capacity (continuous and 1-hour rating) to be calculated by Bidder.

- 11.1.3 An additional simulation is required for which the Bidder shall use an “All out” operation for simulation purposes.
- 11.1.4 The Bidders may determine the travel time and average speed based on the provided track alignment data for an “All out” simulation.
- 11.1.5 The data of radius of curves, curve lengths and speed limits at curves is available in Appendix K.
- 11.1.6 All other simulation parameters not included in the listed conditions shall comply with the Employer’s Requirements.
- 11.1.7 Load weighing shall be provided for all car weights up to crush loading condition. The failure of electric braking to provide the requested performance shall initiate supplemental friction braking.
- 11.1.8 The traction power circuit shall be cut out if pressure of main reservoir is below the minimum required working pressure. In this case, the emergency brake shall be operated at the same time, and the line breaker (LB) shall be open when the emergency brake is operated.

- 11.1.9 The propulsion system design shall automatically compensate for wheel diameter variations between axles on the same car of no less than 6 mm. The Contractor shall incorporate the function that each car wheel diameter is input from the TMS. If this function is not used or used incorrectly, the propulsion system shall operate recognizing the wheel diameter as 820 mm.
- 11.1.10 The Contractor shall be required to perform a combined propulsion system test in accordance with a procedure which shall be reviewed by the Engineer. This test shall consist of installing the entire propulsion system, including the power conversion equipment (PCE), traction motors and associated cabling. The temperature of critical components, amongst other parameters, shall be monitored to gauge suitability for the intended service.
- 11.1.11 The equipment to be supplied shall require minimal maintenance, and any items requiring periodic attention shall not require such at intervals less than monthly.
- 11.1.12 The propulsion system shall be provided by a supplier having had a minimum of 5 years of demonstrable experience in supplying service-proven, considerably reliable 3-phase AC propulsion equipment in a similar operating environment to that in Manila.
- 11.1.13 Speed estimation during the initial stage of both acceleration and deceleration shall be within 200 ms after motor current begins to flow. In particular, even in the case of low speed range and the recession starts, speed estimation shall be completed successfully to prevent unnecessary vibration, overcurrent to the motor. In addition, the speed sensor design shall prevent unnecessary vibration in the event of start-up during roll-back.
- 11.1.14 For the parts that shall be considered exothermic, thermal simulation shall be performed, e.g. switching device module, HSCB, LB, and main circuit wires. This simulation shall be performed based on the run curve at the most severe riding rate, taking into account the heat dissipation environment inside the box. Simulation results shall be validated during testing and commissioning with and without load.
- 11.1.15 The design life of the main circuit semiconductors and the filter capacitors shall be 30 years or more, PECE shall have the design life of 12 years or more.
- 11.1.16 Constant speed and low-speed operation function shall be provided.
- 11.1.17 ATO and PSD will be installed in the future. Therefore, the propulsion system shall be designed to be able to interface ATO and PSD easily and shall be considered about the ATO running pattern mentioned as below.
- 11.1.18 The capacity of propulsion system shall be determined at 20t/car load condition provided following table. The Contractor shall calculate capacity based on data shown in Appendix H, I, J, and K. Provisions of calculation shall be determined based on discussion between the Engineer and the Contractor.

Alignment	Running Pattern	Traction Performance
MCRP	All-Out Re-propulsion when train speed downed under predetermined values (-5km/h) from speed limited	Appendix E
NSCR	All-Out Re-propulsion when train speed downed under predetermined values (-5km/h) from speed limited	Appendix E
NSRP-South	All-Out	Appendix E

	Re-propulsion when train speed downed under predetermined values (-5km/h) from speed limited	
--	--	--

11.2 Power Conversion Equipment (PCE)

- 11.2.1 The PCE and the PECE shall consist of all necessary equipment to condition the power supply from the catenary system into a fully useable power supply to drive the traction motors under fully controlled conditions, meeting the requirements with respect to speed, acceleration, torque, and regenerative braking. Such equipment shall include, but not limited to:
- a. Inverter equipment – Hybrid-SiC Technology, self-cooling;
 - b. Inverter self cooling equipment;
 - c. Inverter controls;
 - d. Inverter protection equipment, except the main circuit breaker;
 - e. Propulsion system interface with the door control, on-board signaling systems and TMS;
 - f. Propulsion system control interface with the train lines; and
 - g. High Speed Circuit Breaker (HSCB) and Main Fuse.
- 11.2.2 PECE shall be equipped to detect the onset of wheel slip and slide, and shall regulate the PCE to control the event. The PECE shall provide the regenerative brake feedback signal to the TMS to ensure smooth brake blending.
- 11.2.3 The PCE equipment shall be sufficiently convection cooled (self-cooling). The PCE enclosure shall be integrated with the car design to ensure that the motion of the car produces sufficient air flow across the cooling fins to produce the required heat transfer. The Contractor shall be required to demonstrate by calculation and by test, the maximum thermal stress upon the equipment that shall not result or contribute to reduction of PCE service life, under expected service conditions.
- 11.2.4 The inverter power semiconductors shall be housed in watertight, dust proof enclosures meeting IP55 requirements and shall be convection cooled. The devices shall not be protected by fuses.
- 11.2.5 The output of the propulsion inverters shall incorporate ground fault protection. Upon detection of a ground fault, the affected inverter shall be shut down. Three successive detections of ground faults within a predetermined time, to be reviewed by the Engineer, shall cause the locking out of the inverter system and shall only be reactivated by authorized personnel. A ground fault shall be displayed in the driver’s cab and shall be registered in the TMS.
- 11.2.6 The PCE shall be provided with over-temperature protection, which shall initiate a reduced level of performance from the affected unit. Upon temperatures returning to normal, the PCE shall automatically reset. PCE over-temperature shall be displayed in the driver’s cab and shall be registered in the TMS.
- 11.2.7 The propulsion equipment shall be of very high reliability, low maintenance and fit for purpose in a harsh operating environment to that in Manila.
- 11.2.8 The design of the entire propulsion system shall be submitted for review by the Engineer.

11.2.9 If the load to regenerative power is insufficient, PECE shall limit the regenerative braking torque to the proper regenerative braking torque, whilst making maximum use of the regenerative braking torque considering not only catenary voltage but also the electric load. However to prevent catenary voltage from becoming too high, the upper limit of the catenary voltage shall be maintained. This function shall be able to be adjusted in consideration of the operating situation of regenerative electric power absorbing equipment installed in the substations, ride comfort, cooperation with friction brake, deceleration difference from normal time, etc.

11.3 Wheel Slip/Slide Control System

11.3.1 The propulsion system shall be equipped with a wheel slip/slide detection and control system to maximize the utilization of available wheel/rail adhesion under low adhesion conditions, to eliminate damage and unnecessary wear to wheel treads. Slip/slide on motor car shall be detected on per the average velocity of four axle basis estimated, and protection shall be provided on a four-axle basis.

11.3.2 The hardware and software which is mounted in the propulsion system shall reliably detect all-wheel-slip/slide conditions that may occur on any axle in the motor car, and shall initiate actions that minimize or terminate these conditions, whether they occur randomly or synchronously.

11.3.3 The system shall compensate for wheel size differences. The detection of average four axles speed differential to body shall initiate the required reduction of torque to eliminate this speed difference. Usually, the wheel slip/slide control system shall operate so that the average axle speed differential to body speed is within 1 km/h.

11.3.4 In rainy condition, it is necessary to make maximum use of the regenerative braking torque by the appropriate adhesion limiter and slide control, and try to control the deceleration lowering, suppress the wheel damage, and prevent the ride comfort deteriorating.

11.3.5 The operation of the sliding control shall be basically based on operating within 1 to 3 km/h with the goal of re-adhesion within 1 km/h.

11.4 Propulsion Equipment

11.4.1 Traction Motor

11.4.1.1 The traction motor shall be a mass produced totally enclosed AC squirrel cage induction machine over 5 years’ service proven history with a good reliability service proven record, and shall be reviewed by the Engineer.

11.4.1.2 Traction motor bearings shall be equipped with sufficient and easily accessible standard grease fittings.

11.4.1.3 Traction motor bearings lubricated by grease shall be able to be changed in a non-disassembling within 30 minutes.

11.4.1.4 The non-disassembling system shall be proven. The attachment of a traction motor cooling fan, if equipped, shall be robust to withstand all levels of traction motor operation in any service condition.

11.4.1.5 The traction motor shall be rated and specified to meet all of the performance requirements according to Sub-Clause 1.8 of the Technical Requirements.

11.4.1.6 In addition, as a minimum, the traction motor shall have the following characteristics:

- a. The efficiency in the rating shall be more than 94%;
- b. The continuous and 1-hour rating shall be rated to meet the performance requirements; to be calculated by the Bidder;

- c. Three-phase four-pole totally enclosed squirrel cage induction;
- d. Insulation performance shall be Class 200 or more;
- e. The grease used shall be Unimax-R2 or the equivalent with similar features;
- f. There shall be no speed sensor;
- g. Insulated bearings shall be applied at both the drive side and the non-drive side;
- h. The non-disassembling system shall be applied at both the drive side and the non-drive side for changing bearings easily
- i. Bearings shall be lubricated by grease; and
- j. The basic design of the bearing shall be refilling without decomposition at 600,000 km and exchange at 1.2 million km

11.4.2 Gearbox and Coupling

- 11.4.2.1 Each traction motor shall drive its axle via a parallel drive, reduction gearbox and coupling arrangement from a design derived from system with extensive, successful rapid transit history.
- 11.4.2.2 The performance of the gearbox shall be fully compatible with the remainder of the propulsion equipment. The gears shall be oil lubricated, and an inspection cover shall be provided in the gear case for visual inspection. The gearbox shall incorporate sufficient baffles, oil passageways, etc. to ensure adequate lubrication under all service conditions and in any rotational direction. It shall not be necessary to check the oil level at intervals less than 65,000 km, nor add oil at intervals less than 130,000 km.
- 11.4.2.3 The gearbox shall utilize labyrinth seals between rotating components, which shall not require replacement between major overhauls. Adequately bolted and gasketed inspection openings shall be provided to enable all gears to be inspected with the car body on the bogie. A magnetic drain plug shall be provided. A sight glass shall be provided to visually check the oil level in the gearbox at any given time. An inlet port shall be provided for refilling gear oil, if necessary.

11.4.3 Maintenance Requirements

- 11.4.3.1 No component in the PCE and the PECE except for cover packing, power supply unit, gate IF, contacts of HSCB and LB shall require removal or replacement for at least 12 years.
- 11.4.3.2 Any fault in the PCE or the PECE shall be logged and into the event recorder of the TMS and PECE. Any fault intervention shall be displayed in the TMS monitor. Logged faults into the TMS and PECE shall be stored and remain until a certain number of faults is contained. PECE shall have an ordinary and high-speed trace function. In high-speed trace function, logged faults related to the switching of the element and behavior of instantaneous current and voltage, etc. shall be required to be available for fault diagnostic analysis.
- 11.4.3.3 Means shall be provided to automatically discharge capacitors whose voltage might present a hazard to a maintenance worker opening any enclosure. Discharge time shall not be more than 5 minutes.

12 Primary Power System

12.1 Current Collection

- 12.1.1 The 1500 V dc power shall be collected from the overhead line system using electrically operated pantographs. The pantograph assembly shall permit all necessary movement, taking into account the overhead line installation tolerances/clearances, vibration of Rolling Stock, deflation of suspension etc. and maintain the complete and effective collection of electrical power. Sintered alloy shall be used as the material of the contact strip. The pantograph within the train shall be equipped with both the function to raise and lower all at the same time and the function to raise and lower individually.
- 12.1.2 The upper structure of the pantograph shall be equipped with a pair of parallel guide bars for supporting the current collector and to provide a higher guidance function to prevent shaking of the catenary. Spring structure shall be designed to suppress the current collector from leaving the overhead catenary.
- 12.1.3 A lightning arrester shall be installed on the appropriate position adjacent to the pantograph.
- 12.1.4 The pantograph shall be mounted on the roof with double insulation.
- 12.1.5 The pantograph shall be in compliance to JIS E 6302 or other equivalent standards.
- 12.1.6 The rigid overhead conductor shall be used in some section. For rigid overhead conductor, since detachment tends to occur easily, the spring structure to suppress detachment shall be equipped.

12.2 Not Used

12.3 Input Protection (HSCB)

- 12.3.1 The power supply shall be protected by a heavy duty, transit proven, ultra-high speed circuit breaker, which shall be capable of handling the short circuit capacity of the PCE. The High Speed Circuit Breaker (HSCB) shall be installed in a dedicated explosion-proof enclosure.
- 12.3.2 The Contractor shall select the HSCB with sufficient capacity to break the short-circuit current. The set value to trip shall be appropriate so as not to trip unnecessarily when the catenary voltage changes rapidly in actual operation. The Contractor shall submit the Technical Requirement of the HSCB including tripping performance for the review by the Engineer.
- 12.3.3 Tripping of the HSCB shall be displayed in the driver’s cab and shall be registered in the event recorder of the TMS and PECE. The HSCB shall be resettable from within the driver’s cab.
- 12.3.4 Sufficient attention about HSCB, conductor to be connected, the performance of the grease to be used and fastening torque of conductor, etc. shall be given to the heat generated by the current which is assumed in the maximum actual operation current pattern.

12.4 Current Return

- 12.4.1 The negative return current from the 1500 V dc circuits shall run to an insulated common point located under the car and shall be submitted for review by the Engineer. The insulated common point shall be connected to 4 axle ground brushes per car through removable jumper cables. The cable and cable arrangement shall be carefully chosen and installed to withstand all car service conditions and shall not be subject to induced premature failure.
- 12.4.2 The car body grounding shall be separated from the power return circuits and the car structure shall not be used as normal circuit return path for any electrical equipment. Separate current return assemblies shall be provided for the 1500 V dc and car body ground respectively.

- 12.4.3 Any dirt build-up shall not affect the insulation and performance of the current return assembly. Suitable air vent and drain holes shall be provided to avoid accumulation of dust and water. Carbon dust shall not in any way contaminate the axle bearing lubrication or restrict carbon brush movement.
- 12.4.4 The ground brush housing shall allow ready access to the brushes and electrical contacts by maintenance technicians.
- 12.4.5 The ground brush arrangement and details shall be reviewed by the Engineer.
- 12.4.6 The Contractor shall produce a complete earthing scheme, which shall prevent traction return current passing through motor and axle bearings, gearboxes, bogie center bearings, couplers, or any path other than the designated path. The earthing scheme shall be submitted to the Engineer for review.

13 Auxiliary Electrical System

13.1 General

- 13.1.1 The Rolling Stock shall have independent auxiliary power feed at each required voltage. The AC output shall be sinusoidal under all conditions of load. Emergency loads shall include:
- a. Emergency lighting;
 - b. All exterior lights;
 - c. Communication systems, AP system and CCTV system;
 - d. TMS and brake controls;
 - e. Door controls;
 - f. On-board signalling equipment;
 - g. Cab console indicators;
 - h. Horn;
 - i. Wiper control/system; and
 - j. Ventilation system
- 13.1.2 All electrical equipment on the train, other than the PCE and the supply to the auxiliary power supply equipment (APSE), shall operate using the following nominal voltages, respectively:
- a. 440 V ac, 3-phase, 60 Hz;
 - b. 220 V ac, 1-phase, 60 Hz;
 - c. 100 V dc; and
 - d. 12/24 V dc.
- 13.1.3 The AC output shall be regulated within $\pm 3\%$ for all variations in input voltage and output load.
- 13.1.4 The DC output shall be regulated within $\pm 1\%$ for all variations in input voltage and controlled not to damage the battery that has a floating charge.
- 13.1.5 The Contractor shall submit the required capacity calculation considering ATO, PSD, CCTV (in the future installation) and 10 cars train-sets in the future extension and reviewed by the Engineer.
- 13.1.6 The design of the auxiliary electrical system shall have sufficient capacity to provide backup power for normal operation of the emergency loads even in the event of lost overhead power. The design of the auxiliary electrical system and its capacity, including the backup power, shall be reviewed by the Engineer.
- 13.1.7 This system shall have Fuse and HSCB.

13.2 Auxiliary Power Supply Equipment (APSE)

- 13.2.1 The train shall be equipped with APSE capable of supplying all loads continuously. The failure of an APSE shall be displayed in the driver’s cab and shall be recorded in the TMS and APSE. At least one dead battery start feature shall be incorporated in the train set, which shall be located in the driver’s cab.
- 13.2.2 The APSE shall consist of an auxiliary power inverter (Si-IGBT or Hybrid-SiC Technology, self-cooling), to supply all AC power, and a low voltage power supply (LVPS) to provide low voltage DC power.

- 13.2.3 When designing the auxiliary power inverter, particular care must be taken to account for the simultaneous starting of large auxiliary loads, such that rapid cycling is avoided (particularly the VAC compressor). The inverter shall use a control scheme that contains extensive self-diagnostic logic, and receptacles shall be placed in the car interior and exterior to allow the connections to any necessary test equipment.
- 13.2.4 The auxiliary power inverter output transformer shall be galvanically isolated, and the secondary windings shall incorporate a ground fault protection system. Upon detection of a ground fault, a fault message shall be transmitted to the TMS.
- 13.2.5 The LVPS shall provide the power to all system controls, including the PCE, friction brakes (computer, brake control units, dump valves, etc.), VAC equipment, lighting, communication equipment, doors, radio, on-board signaling, etc. The LVPS shall be solid-state and shall contain appropriate transient suppression and protective circuitry. The LVPS shall also incorporate appropriate fault and operation indicating lights and test switches. The failure of an LVPS shall be recorded in the TMS and APSE. Logged faults into the TMS and APSE shall be stored and remain until a certain number of fault are contained. APSE shall have an ordinary-speed and high-speed trace function. In high-speed trace function, logged faults related to the switching of elements and behavior of instantaneous current and voltage, etc. shall be required to be available for fault diagnostic analysis.
- 13.2.6 The output of the LVPS shall be routed to the low voltage distribution panel/cabinet inside the car. The negative return current from each subsystem shall run individually to the insulated common point given Notice of No Objection by the Engineer located in an enclosure under the car.
- 13.2.7 The entire APSE and controls shall be reviewed by the Engineer.
- 13.2.8 If APSE stops to operate by a serious failure, a switch which can reset from the driver’s cab shall be installed.

13.3 Redundant System

- 13.3.1 Each of the APSE shall perform in parallel and synchronous operation with the adjacent APSE(s). In the event of fault on any APSE, the adjacent APSE(s) shall not be affected and shall supplement the load under the failed APSE. A signal of VAC degraded mode shall be transmitted to the VAC(s) of the affected area through TMS.

13.4 Circuit Breaker Panels and Isolating Switches

- 13.4.1 The following distribution panels shall be provided:
 - a. Low voltage (100 V dc) circuit breaker panel;
 - b. 220/440 V ac circuit breaker panel;
 - c. All 220/440 V ac circuit breakers shall be located in a separate enclosure, and shall individually protect the circuits;
 - d. Panel for auxiliary power supply equipment;
 - e. Spare circuit breakers for all panels; and
 - f. All isolating switches and circuit breakers necessary for car intervention shall be placed inside the driver’s cab, under the dashboard for easy access and use.
- 13.4.2 All circuit breakers and switches necessary for car revenue line fault intervention shall be located inside the driver’s cab. The final list of circuit breakers and switches shall be subject to review by the Engineer. All circuit breaker panels shall be reviewed by the Engineer.

13.5 Emergency Power Supply

- 13.5.1 When battery capacity decreases, pantographs cannot be raised and APSE cannot operate. For this time emergency power supply shall be equipped to be able to raise the pantograph and to start APSE.
- 13.5.2 When APSE starts to operate, the circuit breaker should not be tripped by an inrush of current to the reduced capacity battery.
- 13.5.3 The way in which the emergency power supply raises the pantograph and starts APSE shall be reviewed by the Engineer.

13.6 Battery

13.6.1 General

- 13.6.1.1 The battery shall have sufficient capacity to supply all low voltage power loads (which includes ventilation system, emergency lighting, etc. listed as emergency loads under ERT Sub-Clause 13.1) during failure of the low voltage power supply for a minimum period of one (1) hour of normal train operation and for a minimum period of 90 minutes of passenger emergency lighting. The Contractor shall submit the battery capacity for the Engineer to review taking into account not only this requirement but also an appropriate allowance rate.
- 13.6.1.2 The functions necessary for power failure for calculating the battery capacity shall comply with all relevant requirements in Japanese Ministerial Ordinance, MLIT Chapter 8, Article 85 (Functional relationship of equipment at power failure).
- 13.6.1.3 All cells shall be standard size, and the battery cases shall be made of a material having good thermal stability and suitable chemical resistance, and shall be translucent.
- 13.6.1.4 The battery shall be designed to withstand the shock and vibration conditions associated with a rugged rail-service environment.
- 13.6.1.5 The battery has a floating charge relative to the DC output from APSE. In such usage, the battery shall operate normally with no maintenance intervention for 12 years. The Contractor shall select such a service-proven battery and APS.
- 13.6.1.6 In float charging, the output voltage of the APS and the charging characteristics of the battery shall be completely compliant, and insufficient charging and overcharging shall not occur.
- 13.6.1.7 The Contractor shall submit the required capacity calculation considering ATO, PSD, CCTV (in the future installation) and 10 cars train-sets in the future extension and reviewed by the Engineer.

13.6.2 Battery Installation

- 13.6.2.1 The battery shall be installed under the car and shall be accessible from the side of the car. The battery box shall be ventilated by natural air convection and have drain holes. The batteries shall be mounted in a stainless-steel roll-out tray, with positive stops when pulled out and a lock in the stored position. Alkali-resistant paint shall be applied to the battery box and tray.
- 13.6.2.2 The roll-out tray shall have resinous wheels so as to insulate the box and the carriage.
- 13.6.2.3 Wiring in the box, even if the carriage is moved, shall be considered so that unnecessary slack does not occur, especially when the carriage is moved or the lid is closed; wiring in the box shall be fixed appropriately so as not to be squeezed.
- 13.6.2.4 Fall prevention stopper shall be provided so as not to allow the carriage to fall when the carriage is being pulled out.

13.6.3 **Battery Contactor**

- 13.6.3.1 The battery contactor shall be a non-contact contactor for the opening and closing control of the 100 V dc circuit from the storage battery in the control voltage 100 V dc system and shall be composed of a control unit, the main circuit unit in which a semiconductor shall be incorporated and the circuit that shall be operated from the driver’s cab.
- 13.6.3.2 The circuit to confirm whether the storage battery contactor is ON or OFF shall be incorporated, and the actual condition of the storage battery contactor shall be displayed in the TMS.

13.6.4 **Battery Circuit Open Switch**

- 13.6.4.1 The battery circuit open switch shall be equipped to work safely for maintenance, replacement or construction, etc.
- 13.6.4.2 When this switch is opened, it shall be necessary to make it clear that the state is clear, for example that the lid is not closed.

14 Train Management System

14.1 General

- 14.1.1 The Train Management System (TMS) shall centrally manage information and has functions such as transmission of operation control commands e.g. powering and service braking, failure monitoring, function inspection, crew support etc. by utilizing a transmission line, and shall be designed to improve car function and maintenance efficiency.
- 14.1.2 Basic transmission, transmission with some mounted equipment and between the car and the next car shall be by Ethernet connection, and large data sets shall be transmitted and collected at high speed.
- 14.1.3 In normal operation, with no equipment failures, the TMS shall be the primary command and control system for each consist. The TMS shall not be critical to the safety of each consist.
- 14.1.4 ATO will be installed in the future. Therefore, TMS shall be designed to be able to interface with ATO easily and shall be considered about the structure of software.
- 14.1.5 The TMS shall be sufficiently service-proven deal with control command and information within the train which are extremely important, but not safety critical.
- 14.1.6 Hardwired train lines in addition to the TMS shall be provided for the basic train operation functionality for the following critical systems as a minimum:
- a. On-board signaling control, except for the part related to the maximum service brake;
 - b. Emergency brake control;
 - c. Door enable;
 - d. Door open/close;
 - e. Battery control;
 - f. Pantograph control; and
 - g. Radio/public address system.
- 14.1.7 The arrangement shall allow for basic consist operation in the event of a TMS failure.
- 14.1.8 The TMS shall be capable of performing a bi-directional communication with the on-board signaling equipment for control function if required under the ATO mode.
- 14.1.9 The Contractor shall ensure that all signal inputs received from on-board signaling equipment and output signals exported to the on-board signaling system shall be recorded and shall be available for retrieval for analysis/record purpose. All signals (input/output between the Rolling Stock and the on-board signaling equipment) shall generally be routed through the TMS. The CP NS-01 Contractor will provide the requisite interface signal to the Contractor during the interface meeting.
- 14.1.10 The TMS shall be connected to two reasonably wide LCD screens mounted in the driver’s cab console for fault indication, alarm monitoring, control initiation and data entry, etc.

14.2 Fault Indication

- 14.2.1 The TMS shall include a fault indication function, which shall display critical faults to the driver and any further abnormal conditions recorded in the event recorder.
- 14.2.2 When a critical fault is detected in the train, the TMS shall automatically change the screen to fault indication mode. The list of critical faults that shall be catered for shall be submitted to the Engineer for review.

14.3 TMS Design Requirements

- 14.3.1 The TMS shall perform control initiation including acceleration and deceleration (except emergency brake and security brake), data acquisition, data processing, data communication and data presentation functions. The TMS shall be able to automatically identify the car it is installed in;
- 14.3.2 Interfacing capability shall be provided with twenty percent (20%) spare unallocated car system input/output capacity for future use and when utilized it shall not produce any adverse performance impact on data throughput performance;
- 14.3.3 The transmission mode and protocol of the TMS shall be of industry standard and maintain reliable operation and shall be immune to interference or performance degradation in the environment influenced by electro-magnetic interference (EMI) and harmonics generated from the traction power converters, variable voltage variable frequency (VVVF) inverters and static inverters;
- 14.3.4 A single point failure of any individual part shall not cause any adverse performance impact or cause loss of data in control transmission;
- 14.3.5 The TMS shall perform fault analysis, event log fault occurrence, determine the health of the car systems, failure management actions and present alarm and condition status to the train operator. The event recorder shall be configured to sum repetitive faults, and when the memory is full, the next fault shall result in the oldest fault being dropped and the newest added;
- 14.3.6 Fault analysis algorithms, data acquisition routines and data storage logic shall be programmed and presented using a Windows type of user interface, using the latest windows Operating System (OS) or other equal industry OS;
- 14.3.7 On-board fault occurrences logging and degraded performance condition monitoring logging shall be provided as an integral part of the TMS. The Contractor shall nominate the key indicators of degraded performance of the principal car systems for review by the Engineer;
- 14.3.8 The TMS shall always display a warning message on a per car system overview basis for any consist system detected with an active fault alarm condition. Train operator selectable screen page listing of active fault alarms for the total consists shall be provided;
- 14.3.9 The TMS programming shall allow for easy data entry and function changing and upgrading throughout the life of the system;
- 14.3.10 The TMS display shall use back-lit colored LCD technology and shall be software driven by the TMS. Commands shall be entered by the train driver via touch screen;
- 14.3.11 Two TMS monitors shall be prepared. Normally, each piece of information shall be appropriately sorted and displayed on the two units. In the event of failure of one unit, it is necessary to have a backup function to automatically display all information on the remaining healthy one;
- 14.3.12 The TMS display shall provide the train driver with information regarding the operating status of the car consist, car/system health and failure management actions performed by the TMS. The display shall provide the facility for train operator to input railway operations information (e.g. staff number, train run number, etc.);
- 14.3.13 The TMS shall have the function to calculate running distance for trip meter;
- 14.3.14 The TMS shall get time and date information from either Communications or the on-board signaling system and linked equipment shall get the time from the TMS;
- 14.3.15 TMS configurations and options shall be reviewed by the Engineer;
- 14.3.16 The display shall provide the facility for maintenance personnel to input maintenance information (e.g. wheel diameter);

- 14.3.17 The master clock system shall provide to the various train borne systems an accurate source of time and date information;
- 14.3.18 In transmission concerning functions related to driving and devices with high importance, that is, control transmission, the backbone transmission line shall have two systems, so the ethernet system has redundancy. These two main transmission lines shall be a loop type or a ladder logic type to have higher redundancy. Each car shall have car switch (VS) for 1 system and 2 systems. End Device (ED) shall be connected to VS. A central unit shall be installed in both leading cars. Here VS is the car switch and ED is the End Device. The simplified block diagram is shown in Appendix F;
- 14.3.19 In transmission concerning functions related to CCTV, monitor information, information not directly related to driving, the backbone transmission line shall have one system as the ethernet system. Each car shall have a VS. The simplified block diagram is shown in Appendix G;
- 14.3.20 The transmission lines shall be capable of network isolation by V-LAN. The communication speed shall be maintained for the application possible speed. I/O shall be digital input/output. The storage method shall be a large capacity disk method. The control method shall be a high response processing method;
- 14.3.21 The TMS shall comply with IEC 61375 (including branches excluding 2-6 and 3-3) or equivalent. Moreover, careful consideration shall also be given to global standards, redundancy systems, compactness and weight reduction;
- 14.3.22 Based on the release state information of the propulsion system or the brake system, the required acceleration / braking force of the whole formation shall be computed, and backup control shall be performed so as not to interfere with operation as much as possible;
- 14.3.23 Various information recorded in the TMS shall be able to cooperate with MMS (Maintenance Management System). Details shall be discussed with the CP NS-01 Contractor;
- 14.3.24 As departure inspection, in addition to the motoring test, the door test, the brake test, the function to judge whether there is no abnormality in the car shall be equipped; and
- 14.3.25 Accumulated traveling kilometers, power consumption, operation status of the air compressor, number of times of operation of the line breaker, etc. shall be recorded of a record of car condition, monitoring and inspection.
- 14.3.26 Passenger load information from BCU (second suspension pressure) shall be interfaced with communication system and signaling system.

14.4 Event Recorder

- 14.4.1 The event recorder can either be incorporated its function into TMS or as a separate device and shall comply with IEC 62625-1 or equivalent. The TMS shall also be capable of recording, with sufficient memory capacity to store more than 30 days operation, which shall include, but not be limited to, the following:
 - a. Speed;
 - b. Status of train control mode;
 - c. Power controller position and power equipment response;
 - d. Brake controller position and brake equipment response;
 - e. Traction motor current;
 - f. Main airline pressure / brake cylinder pressure;
 - g. Emergency brake events;
 - h. Brake events under Manual Operation;

- i. Driver safety device;
- j. Status of doors and control;
- k. ACU events;
- l. Wheel slide;
- m. Operation of safety related cut-out switches;
- n. Overhead line voltage;
- o. Battery voltage;
- p. Date and time;
- q. Location; and
- r. Battery contactor status (on/off).

14.5 Master Clock

- 14.5.1 The TMS shall be able to communicate with the Communication or the on-board signaling systems to obtain the time and date details to provide the master clock information to other on-board systems.

14.6 Electrical Jumper Wire

- 14.6.1 The electrical jumper wire that is necessary for transmission between the cars shall be specified by the TMS supplier and shall achieve 1 million cycles of performance test.

15 Communication System

15.1 General

- 15.1.1 The Rolling Stock shall be equipped with communications equipment to provide voice, video and data services.
- 15.1.2 This Clause describes the requirements for the CP NS-01 (Communication System) Contractor, and the CP NS-02 (Rolling Stock) Contractor.
- 15.1.3 Both Contractors shall ensure that all requirements of the specification pertaining to interfaces are comprehensively fulfilled. Below is a brief outline of responsibilities between the CP NS-02 and CP NS-01 Contractors. Further details are specified in following Sub-Clauses:

Table 15.1 Responsibility Matrix

SOW	Item Description	By Contractor
1	Public Address (PA) System to broadcast speech messages to train passengers from the driver’s cab. Facility to broadcast over the train PA System from the Operations Control Center (OCC) with the associated message content relayed to the train via the Train Radio System.	CP NS-02 CP NS-01
2	Guidance display for the customer shall be placed above the door in the passenger coaches (or saloons). Guidance display shall be digital signage to present on dedicated TV-style color monitors using 17-inch LCD displays, and it shall be possible to display the destination, the next station, the side of opening door, transit information, line map, time to arrive at each station, the guidance of the next station and attention, etc. One monitor shall be installed on one door. Securing space and supplying the wiring shall be prepared so that another screen can be added for advertisement. Advertisement display for the customer shall be placed above the window between doors in the passenger coaches (or saloons). Advertisement display shall be digital signage to present on dedicated TV-style color monitors using 21.5-inch or more LCD displays.	CP NS-02
3	Passenger emergency intercom to provide audio communication between carriages and the driver’s cab to enable passengers to talk to the driver should an emergency situation occur within the train carriage. In case the driver does not pick up the passenger emergency intercom within a predefined time, it automatically connects to the OCC, using the onboard radio.	CP NS-02 CP NS-01
4	Driver’s intercom system to allow full-duplex audio communication between driver’s cabs.	CP NS-02
5	Train radio system to allow full-duplex audio communication between the driver and the OCC. Additional interfaces shall be provided within the OCC to relay to the trains PA audio messages.	CP NS-01

SOW	Item Description	By Contractor
	Train Protection Radio	
6	Outdoor display (mounting on the train) consisting of a full color LED to display destination stations for the passengers on the platform.	CP NS-02

15.2 General Requirements

- 15.2.1 The CP NS-02 Contractor shall equip each driver’s cab with the necessary Human Machine Interface (HMI) facilities for the operation, control and monitoring by the driver of the on-board communications systems. The number of handsets required for driver use shall be rationalized and kept to a minimum. In particular, the CP NS-02 Contractor shall utilize the TMS monitor with respect to the display.
- 15.2.2 Subject to any reliability constraints, both CP NS-02 and CP NS-01 Contractors shall consider the integration of all communication operator functions into a single HMI to minimize space requirements.
- 15.2.3 All of the cab-mounted equipment shall be fit for purpose and ergonomically designed taking account of human factor issues.
- 15.2.4 Unless otherwise stated, the equipment shall be controllable from the operational driver’s cab and must be fully functional over a length of 8-car trains. The on-board communications equipment shall be fed via individual circuit breakers from a fully regulated low voltage power supply equipped with a battery back-up.
- 15.2.5 The design shall incorporate the latest proven technology, which shall be highly scalable and reliable, avoiding common mode failure.
- 15.2.6 The entire installation for each system shall include a comprehensive diagnostic and fault management facility and shall be interfaced to the TMS to log events/incidents and major fault data, to send and to receive a variety of information necessary for control.
- 15.2.7 Suitable security measures and firewalls shall be employed comprising standardized state-of-the-art authentication mechanisms to block unwanted data traffic and access to the on-board communication systems.
- 15.2.8 The equipment shall be robustly constructed and shall be resistant to tampering, vandalism and exposure to liquid spillages, etc.
- 15.2.9 The equipment devices within carriages shall in appearance be aesthetically pleasing and their fitment shall be flush mounted into the carriage body and installed in positions to minimize their exposure to vandalism.
- 15.2.10 The CP NS-02 Contractor shall perform a study to ensure that, within the train carriages all of the communications equipment is positioned, as appropriate, so as to achieve ease of passenger use and passenger viewing without creating an obstruction to passenger flow and without obscuring other facilities such as signs, notices and other displays, etc.
- 15.2.11 The CP NS-02 and CP NS-01 Contractors shall ensure that the required number of antennas be minimized and be positioned taking into account the following:
- a. The effect of the geometry of the installation location on the radiation/reception performance of the antenna and without exceeding the rolling stock gauge;
 - b. The effect of any protrusions which might affect the radiation/reception performance of the antenna;
 - c. The effect of any adjacent aerials on the performance of the radio system;

- d. The risk of being struck or otherwise damaged;
- e. Electrical safety in relation to proximity to exposed HV lines; and
- f. Diversity for improving reception sensitivity.

- 15.2.12 The systems shall, where appropriate, be interfaced to the TMS for provision of accurate time and date information.
- 15.2.13 Suitable automatic test routines shall be available to the driver in the active cab in order that the operational integrity of the on-board communications equipment is verified prior to the train entering passenger service.
- 15.2.14 Externally mounted equipment shall be dustproof and weatherproof and shall be sufficiently robust to withstand frequent train washing involving continuous exposure to high pressure water jets, associated chemical cleaning and mechanical rotary scrubbing brushes.
- 15.2.15 The communications systems shall be fully compliant with industry recognized railway standards, international standards such as ITU-T and ITU-R and applicable national standards.
- 15.2.16 Special attention shall be given to the shielding of all communications equipment and wiring along with any HV protection required.

15.3 Public Address (PA) System

- 15.3.1 The train carriages shall be equipped with public address speakers, which shall enable voice announcements to be broadcast relating to emergency, safety and information messages.
- 15.3.2 For speech intelligibility purposes, the design shall achieve an STI (Speech Transmission Index) in excess of 0.6 under the worst case ambient noise conditions.
- 15.3.3 In the internal design of the train carriages, the CP NS-02 Contractor shall give due consideration to the selection of suitable materials in order that their acoustical properties are complimentary to achieving the specified STI.
- 15.3.4 Consideration shall be given to the installation within carriages of ambient noise sensors to maintain, under varying ambient noise conditions, a more uniform signal to noise ratio for PA broadcast coverage.
- 15.3.5 The driver shall be able to make live announcements over the PA system and shall also have the facility to initiate the broadcast of pre-recorded speech messages accessible from an on-board message library.
- 15.3.6 The OCC operators shall be capable of making live speech broadcasts and initiating the broadcast of pre-recorded speech messages via an interface between the train radio system provided by the CP NS-01 Contractor and the on-board PA system.
- 15.3.7 The PA message library shall be solid state and shall be developed by the CP NS-02 Contractor, with agreement with the Employer.
- 15.3.8 Library messages shall be in both English and Tagalog. Selected messages shall be broadcast firstly in English followed by the same message in Tagalog; each with a pre-set dwell time, the duration of which may be adjusted as an engineering function.
- 15.3.9 The library shall be suitable for being updated at regular intervals, as the situation demands. The CP NS-02 Contractor shall propose an efficient method by which multiple trains may be updated.

- 15.3.10 The message library shall be dimensioned with a minimum storage capacity of 1TByte.
- 15.3.11 Message categories shall include service status, places of interest, safety messages, emergency messages, details of train start location and train destination along with next station details, etc.
- 15.3.12 The PA system shall be interfaced to enable selected safety and emergency messages broadcast on the train PA system within each train.
- 15.3.13 Within each train cab a PA Control unit shall be supplied.
- 15.3.14 PA broadcasts initiated by the train driver shall have priority over other broadcasts.

15.4 Internal Guidance Display

- 15.4.1 The guidance display shall be digital-signage to present on dedicated TV style color monitors, (17-inch LCD), a display to show typically, the destination, the next station, which side door opening, transit information, line map, time to arrive at each stations, the guidance of the next station, etc.
- 15.4.2 The displays for advertisement (21.5-inch or more LCD) shall be installed between doors on both sides (total 6 displays per car). These displays shall be mounted above the window. Advertisement contents shall be installed into this system directly. Also, it shall be prepared to be able to be installed remotely by interfacing with the wireless another system.

15.5 External Destination Sign System

- 15.5.1 The destination sign located at the end of the consist shall provide, as a minimum, information on the train running number along with the start and destination locations of the train service and any special information such as ‘Not in Service’, etc.
- 15.5.2 The destination sign shall be installed externally on each cab car above the windshield and two units on each side of each car above the window.
- 15.5.3 A hinged panel shall be installed in the driver’s cab to provide ready access to the destination sign unit.
- 15.5.4 The destination sign shall be suitably sized with text colors such that passengers waiting on platforms shall be able to see clearly the information displayed on the train approach to the platform under all conditions.
- 15.5.5 The destination sign shall be programmable from the TMS in the driver’s cab.
- 15.5.6 The destination sign in the non-active cab and on the side of the car shall automatically indicate the same destination as in the active cab.
- 15.5.7 The design of the destination sign shall allow manual override in the case of a defect in the electronics system.
- 15.5.8 The Contractor shall propose options for the electronic destination display sign system for the Engineer’s review.
- 15.5.9 Choosing optimal colors according to train type, guidance content and display that is easy for the user to understand shall be implemented.
- 15.5.10 Display contents, colors, fonts, etc. shall be reviewed by the Engineer.

15.6 Digital Signage for Advertising

- 15.6.1 Space and power supply provision shall be made available within the train carriages to enable digital signage as described in Sub-Clauses 15.1 item 2 and 15.4 herein.

15.7 Passenger Emergency Intercom

- 15.7.1 A full-duplex and highly reliable intercom and alarm facility shall be provided to enable an emergency call to be established between passengers in each carriage and the train driver.
- 15.7.2 Quantity of four (4) intercom units shall be provided per carriage and the location shall be reviewed by the Engineer.
- 15.7.3 The intercom communications shall provide high voice quality free from distortions, audible noise and other audio impairment. The carriage intercom unit shall be bulkhead mounted and protected by a break-glass cover.
- 15.7.4 The unit shall be positioned in a readily accessible location and at a suitable height for customer use.
- 15.7.5 The intercom unit shall consist of a switch to initiate a call along with a flush mounted noise-cancelling microphone and loudspeaker.
- 15.7.6 Operation of the emergency switch shall result in the following actions on-board the train:
 - a. An audible and visual alarm by TMS (monitor) shall be made in the driver’s cab also indicating location of actuation;
 - b. The driver shall be able to communicate via a separate dedicated handset for this purpose;
 - c. The emergency voice recorder shall record the conversation for the duration of the call; and
 - d. The event recorder in TMS shall record details of the intercom unit location together with the time and date of the emergency call.

15.8 Driver’s Intercom System

- 15.8.1 A full-duplex and highly reliable intercom facility shall be provided to enable personnel within the driver’s cab at each end of the train to establish voice communications.
- 15.8.2 The intercom communications shall provide high voice quality free from distortions, audible noise and other audio impairment.

15.9 Train Radio System

- 15.9.1 The Train Radio System for the Rolling Stock shall be designed and supplied by the CP NS-01 Contractor for the CP NS-02 Contractor to install on the Rolling Stock. The CP NS-01 Contractor shall provide installation for the first Train Radio System installation on-site. The second trainset shall be installed by CP NS-02 Contractor and supervise by CP NS-01 Contractor. The remaining trainsets radio system shall be installed by CP NS-02.
- 15.9.2 In addition to the communication devices mentioned above, at least the Train Operator Control Panel (TOCP) and the radio transceiver unit shall be included.
- 15.9.3 The TOCP shall be equipped with all facilities necessary for driver operation of the on-board radio facilities and other on-board radio communication equipment and shall typically include:
 - a. Integral flush mounted loudspeaker;
 - b. Volume control;
 - c. Gooseneck microphone;
 - d. Press to talk (PTT) switch; and
 - e. System selector switch.
- 15.9.4 The TOCP shall, as a minimum, enable the following functions to be performed:
 - a. Communication between the cab driver and the OCC via the train radio system;

- b. Communication between the leading and trailing cabs via an intercom system;
- c. Driver announcements from the cab to passengers within the train via the train PA system;
and
- d. Display of major telecoms system alarms.

- 15.9.5 The design shall enable the OCC to communicate with train passengers via the train radio system by broadcasting audio announcements within carriages via the train PA system.
- 15.9.6 The CP NS-01 Contractor shall be responsible for the configuration, set-up and optimization adjustment of the on-board train radio equipment to ensure full inter-operation with the line side train radio network and facilities within the OCC.
- 15.9.7 The CP NS-01 Contractor shall determine, in conjunction with the radio equipment manufacturer, all of the necessary interfacing requirements to the various sub-systems.
- 15.9.8 Within each train cab an integrated hand-held portable radio battery charger with integral cradle shall be provided by CP NS-01 and to be installed by CP NS-02.
- 15.9.9 The train radio system shall be designed by the CP NS-01 Contractor to allow automatic switchover to the other radio unit on the train, in the case where there is failure of other radio lines.

15.10 Operation of the Mobile Communications Devices

- 15.10.1 The train structure shall be designed so as not to impede the operation of mobile phones and other similar radio communications devices within the train carriages whilst accessing public operated mobile communications networks such as GSM (2G), UGPS (3G), LTE (4G) or other more advanced network.
- 15.10.2 In particular, for such signals the attenuation (penetration loss) of the side windows shall not exceed 3dB when the train is on straight track with the side windows perpendicular to the rail.

15.11 Preparation for Wi-Fi system

- 15.11.1 Preparation for Wi-Fi system shall be designed in consideration with follow but not limited to:
- a. Space and position for attaching
 - b. Materials of interior near the attachment
 - c. Capacity of powering
 - d. Preparation of circuit
 - e. Preparation of interface
- 15.11.2 Care shall be paid to assume that two individual systems of two companies are introduced.

16 Signaling System Interface

16.1 General

- 16.1.1 This Clause describes the interface requirements as required for the CP NS-02 (Rolling Stock) Contractor with the Signaling Contractors of CP NS-01 and CP04 (if necessary).
- 16.1.2 The fleet shall be equipped with ETCS Level 2 (900 MHz frequency for ETCS Level 2 to be confirmed) on-board equipment which is envisioned to operate seamlessly in the entire alignment of Clark to Calamba, as NSCR will be similarly fitted with ETCS equipment. In the future, the alignment will be extended further from either end lines or both; and therefore all trains are foreseen to carry two (2) separate on-board train control systems: one being the ETCS and the other an unknown on-board system which must effortlessly interface with the former. Therefore, the CP NS-02 Contractor shall provide additional space for the second on-board signaling system for future signaling requirements. The additional space shall be similar (with some margin) to the space occupied by the ETCS signaling system adopted for the NSCR Project. This also includes OBU racks, antenna, radar, tachometer, DMI, train interface unit, etc.
- 16.1.3 All associated Contractors shall ensure that all requirements of the specification pertaining to interfaces are comprehensively fulfilled.
- 16.1.4 The CP NS-02 Contractor shall coordinate with the CP NS-01 Signaling Contractor for the design of all appurtenances. The CP NS-02 Contractor shall install all cabling free mating connectors, plug couplers and mounting fixtures for the signaling equipment on all the new trains according to the CP NS-01 Signaling Contractor’s installation specifications.
- 16.1.5 The CP NS-02 Contractor shall provide a report and validate the installation of the CP NS-01 Signaling Contractor’s equipment for each train, for the Engineer’s review.
- 16.1.6 The CP NS-02 Contractor shall provide adequate and stress-relieving provisions for the cabling of the signaling equipment after these are mounted to ensure that cables are not fouling other equipment, chafing or unduly stressed.
- 16.1.7 The CP NS-02 Contractor shall coordinate with the CP NS-01 Signaling Contractor for the detailed interfaces and shall be responsible to provide all supports, brackets, braces, mounting holes, etc. to ensure proper mounting and to allow adequate access to the train-borne signaling equipment.

16.2 Interface Requirements

- 16.2.1 The requirements specified herein are not totally definitive and it remains the responsibility of both CP NS-01 On-board Signaling Contractor and CP NS-02 Contractors to develop appropriate plans during the execution of the work to ensure that:
- a. All interface issues relative to the on-board systems are satisfactorily resolved;
 - b. All equipment and software is supplied, installed and tested and is fully coordinated; and
 - c. All safety related functions shall be designed and tested to the relevant standards.
 - d. ATO/ATP/ROS/RM mode of operation is achieved with all its inherent features.
- 16.2.2 The ATP system provided by the CP NS-01 Signaling Contractor shall issue the braking commands to the Rolling Stock when safety limits are exceeded or when overspeed is detected. The removal of traction power and the correct application of brakes shall be the scope of the CP NS-02 Contractor. The on-board signaling system provided by the CP NS-01 Signaling Contractor shall monitor speed and issue braking commands when safety limits are exceeded.

- 16.2.3 Two (2) separate radio systems shall be provided by the CP NS-01 Signaling Contractor. The first radio system (including on-board equipment) for train radio traffic and the second radio system (including on-board equipment) for transmitting ETCS information, and other data pertaining to control, alarm, events etc. Details of sharing of the two radio systems for sending control and data information, levels and protocols thereof, will be jointly agreed during the interface meeting between CP NS-02 and CP NS-01 Signaling Contractors. The CP NS-02 Contractor may also liaise with CP04 Signaling Contractor if there is any clarification for the required interface to deliver a complete train onboard system.
- 16.2.4 The event recorder within the TMS shall monitor and record data on train speed, direction of motion, time, distance, throttle position, brake applications and operations (including service brake, emergency brake) equipped, cab signal indications, etc. Details of the signals will be jointly agreed and finalized during the interface meeting between CP NS-02 and CP NS-01 Signaling Contractors.
- 16.2.5 The CP NS-01 Signaling Contractor shall provide the CP NS-02 Contractor with a comprehensive list of equipment to be installed on the Rolling Stock; e.g. the sizes and weights of the on-board signaling cubicles, odometer’s, HMI, monitor, train-borne on-board signaling antenna, accelerometers, doppler radar, etc.
- 16.2.6 The CP NS-01 Signaling Contractor shall deliver to the CP NS-02 Contractor all on-board signaling equipment, as applicable, and data to enable installation and testing.
- 16.2.7 The CP NS-01 Signaling Contractor shall supply to the CP NS-02 Contractor pre-wired equipment racks with appropriate connectors for all wiring terminating inside on-board signaling enclosures. Ease of access to the wiring and connectors shall be maintained.
- 16.2.8 For compatibility purposes, the Rolling Stock and the train detection system shall conform to IEC 62427 or an equivalent international standard.
- 16.2.9 Car control circuits developed by the CP NS-02 Contractor shall incorporate the identified interfaces and shall be made available to the CP NS-01 Signaling Contractor, as applicable. The CP NS-01 Signaling Contractor shall provide any specific observations to the CP NS-02 Contractor. Once agreed, the CP NS-02 Contractor shall suitably incorporate these observations into the design.
- 16.2.10 The CP NS-01 Signaling Contractor shall provide the CP NS-02 Contractor with the number of wires/Ethernet connections required between cars to transmit signals from one end to the other end of the train. Provision of redundancy and spares shall be catered for by the CP NS-02 Contractor for train lines /Ethernet connections as deemed necessary by the CP NS-01 Signaling Contractor.
- 16.2.11 The CP NS-02 Contractor shall provide an on-board signaling mode selection switch. The mode selector shall have at least following positions:
- a. Automatic Train Operation (ATO) Mode (reserve for future use);
 - b. Automatic Train Protection (ATP) Mode; and
 - c. Restricted Manual (RM) mode.
- 16.2.12 Under the above modes, the car speed shall be monitored and restricted by the on-board signaling equipment.
- 16.2.13 The CP NS-02 Contractor shall provide an ATP cut-out switch next to the on-board signaling selector. The ATP cut-out switch shall be a sealed switch and the seal position set at the ATP mode. When activated to the ‘cut-out’ position, the seal must be broken and the activation shall be logged into the event recorder. Under the ATP cut-out mode, the train speed shall be restricted by the car overspeed device and restricted to be under 25 km/h.

16.2.14 The CP NS-02 Contractor shall provide the following facilities:

- a. Coupling detection, e.g. by means of coupler switch;
- b. Detachment detection e.g. by means of train integrity relay;
- c. ATO (illuminated) button, to activate the ATO mode; and
- d. ATO door by-pass sealed button, to be activated if manual passenger door opening is required.
- e. Running-on-Sight (ROS) e.g. by means of push button; and
- f. Any other facilities required to fulfill the interface requirements.

16.2.15 The above signals shall be available to the on-board signaling equipment.

16.3 Rolling Stock Characteristics to be Used by the CP NS-01 Signaling Contractor

16.3.1 The model for calculating the Safe Braking Distance (SBD) by the CP NS-01 Signaling Contractor shall identify and take into consideration the various systems response times and train operator’s reaction times. The CP NS-02 Contractor shall provide the assured braking rate at the normal braking efficiency, and at the lowest braking efficiency permitted in service, including brake deterioration, and response times of both service brake and emergency brake, to the CP NS-01 Signaling Contractor. The CP NS-02 Contractor shall provide the speed/acceleration and tractive effort curves, for all loading conditions.

16.3.2 The safety critical braking system of the Rolling Stock shall be of vital fail-safe design and the CP NS-02 Contractor shall provide all documentary evidence required to demonstrate the safety of the braking system to achieve the required safety level.

16.3.3 The deceleration rate used for the SBD shall be coordinated with the CP NS-01 Signaling Contractor’s standard which is to be agreed during the interface meetings. The CP NS-01 Signaling Contractor shall coordinate with the CP NS-02 Contractor on critical interface matters under the supervision of the Employer/Engineer.

16.4 Signaling Details to be Used by the CP NS-02 Contractor

16.4.1 As a minimum, the following data shall be provided by the CP NS-01 Signaling Contractor:

- a. The maximum current and power consumption of the CP NS-01 Signaling Contractor’s equipment under all specified operating conditions;
- b. The number of train wires required, and the function of each;
- c. All control logic outputs and signal protocols;
- d. Electrical characteristics of the interconnection cabling and wiring
- e. Sensitivity levels, and frequencies, which must be avoided; and
- f. The specific heat load for air conditioning purposes.

16.5 On-board Signaling Equipment Cubicles

16.5.1 The CP NS-01 Signaling Contractor shall supply the ETCS on-board signaling equipment. All supports, braces, mounting holes, cabling apertures, etc. required for mounting the rack(s) and its equipment shall be correctly coordinated with the CP NS-02 Contractor to ensure secure mounting and ease of access.

- 16.5.2 The CP NS-02 Contractor shall supply cubicle enclosure for housing the rack(s) and the cubicle enclosure shall suitably be protected to IP52 for it is located inside the cab or saloon.
- 16.5.3 To achieve the on-board signaling control functions, the CP NS-01 Signaling Contractor shall identify any interfacing circuits specifically required for on-board signaling operation and liaise with the CP NS-02 Contractor. This shall include service braking and emergency brake commands.
- 16.5.4 For train control circuits, the CP NS-01 Signaling Contractor shall identify any voltage-free contacts that are to be provided by the CP NS-02 Contractor, including the number and type of electrical signals required between the on-board signaling equipment and the equipment provided by the CP NS-02 Contractor. The two Contractors shall coordinate to agree on signal levels and protocols for all such data.

16.6 Fixtures and Fittings

- 16.6.1 The CP NS-01 Signaling Contractor shall provide the CP NS-02 Contractor with full mounting details, apertures, fixing holes, etc. for all fixtures and fittings.
- 16.6.2 The CP NS-01 Signaling Contractor shall supply the necessary disconnection and terminal blocks, device mounting brackets and plates, flexible conduit assemblies complete with connectors and cables from speed measurement devices to the junction boxes. Additionally, they shall supply all the mechanical fixing items such as the on-board signaling cubicles, HMI, monitor, odometer, train-borne on-board signaling antenna, accelerometer, doppler radar, cables required; all to be supplied in a timely manner.

16.7 Power Supply and Earthing Arrangements

- 16.7.1 Power supply circuits, including positive and negative poles, for the on-board signaling equipment shall be provided by the CP NS-02 Contractor. Both the CP NS-02 and CP NS-01 Signaling Contractor shall coordinate and agree on the power supply voltages.
- 16.7.2 The CP NS-02 Contractor shall provide dedicated earthing arrangements for the on-board signaling equipment. The CP NS-01 Signaling Contractor shall specify the earthing requirements and impedance values for their supplied equipment.
- 16.7.3 Both Contractors shall work together to ensure the power supply cable between the train power supply and the power equipment for the on-board signaling equipment has the shortest route as much as possible.

16.8 Factory Installation and Testing

- 16.8.1 All the special equipment associated with the on-board signaling equipment shall be designed by the CP NS-01 Signaling Contractor and handed-over to the CP NS-02 Contractor. Each Contractor shall be aware of the locations of the other’s manufacturing plants.
- 16.8.2 The CP NS-01 Signaling Contractor shall be responsible for providing all data and training of the CP NS-02 Contractor’s staff in all aspects of on-board signaling installation and testing where applicable. The on-board signaling equipment shall be installed by the CP NS-02 Contractor, under the supervision of the CP NS-01 Engineer, including the wiring for the interface of the on-board signaling equipment with the Rolling Stock.

- 16.8.3 The CP NS-01 Signaling Contractor shall coordinate with the CP NS-02 Contractor for the design of all appurtenances. The CP NS-02 Contractor shall provide a report and validate the installation of the CP NS-01 Signaling Contractor’s equipment for each train to be subject to Engineer’s review.
- 16.8.4 The CP NS-02 Contractor shall provide adequate and stress-relieving provisions for the cabling of the signaling equipment after these are mounted, to ensure that cables are not fouling, chafing or unduly stressed with other equipment or enclosures.
- 16.8.5 The CP NS-02 Contractor shall be responsible to provide all supports, brackets braces, mounting holes, etc. to ensure proper mounting and to allow adequate access to the train-borne signaling equipment.
- 16.8.6 The CP NS-01 Signaling Contractor shall be responsible for the testing of equipment (or initial supervision of Rolling Stock personnel engaged on this until suitably trained), inclusive of the required subsequent functional test.
- 16.8.7 The testing of each car shall comply with the accepted international standards agreed between the two Contractors as agreed with the Engineer.
- 16.8.8 The first train shall be fitted with all the required equipment at the CP NS-02 Contractor’s facility under the supervision of the CP NS-01 Signaling Contractor. Initial integration tests shall be done at the Rolling Stock manufacturer’s premises and performed by the test personnel of both Contractors jointly. Further main line integration tests shall be required to be carried out to ensure all train control functions between OCC and trains, which shall be required to be done jointly by both Contractors on site in Manila including the integrated testing and commissioning. The test certificate for the onboard equipment shall be issued jointly (and duly signed) by both Contractors. As a result of the performance of the first train, if necessary modification(s) occur, the modification shall also be carried out for the remaining trains. Any modification(s) shall be carried out at the Rolling Stock factory before shipment, wherever possible.
- 16.8.9 The CP NS-02 Contractor shall provide facilities including a test track for comprehensive static and interface tests between the Rolling Stock and signaling systems at their premises. The CP NS-01 Signaling Contractor shall be responsible for the provision of special test equipment and instrumentation, if required.
- 16.8.10 The CP NS-01 Signaling Contractor shall then provide intermediate wiring looms for connection of signaling the cubicle connector and train wiring and externally mounted signaling equipment (including balise readers, radar, tachometers, monitor, accelerometers etc.), which shall be installed by the CP NS-02 Contractor during car manufacture. The CP NS-02 Contractor shall then provide an installation report to confirm the completion of the installation works for acceptance by the CP NS-01 Signaling Contractor.
- 16.8.11 Upon delivery of the Rolling Stock to Manila, the CP NS-01 Signaling Contractor shall then install the remaining signaling equipment using the pre-wired loom.
- 16.8.12 Should the need arise for any alterations in the configuration of the respective equipment or systems as a result of the integration test or otherwise, the scope of work and division of responsibility shall be jointly agreed amongst the two Contractors, and a detailed procedure shall be developed prior to the introduction of any modifications.
- 16.8.13 The CP NS-02 Contractor shall provide the facility for the curve test.

16.9 Electro-Magnetic Compatibility (EMC)/Electro-Magnetic Interference (EMI) Interface

- 16.9.1 The CP NS-01 Contractor shall provide a list of frequencies and other electro-magnetic sensitivity requirements to the CP NS-02 Contractor to enable them to avoid such frequency bands in their design, and to provide devices to isolate the source of potential EMI emissions whether they are radiated, conducted, or induced wherever required. Conversely, the CP NS-01 Contractor shall ensure their equipment does not generate spurious or transient frequencies or harmonics, which may adversely affect rolling stock apparatus. Both Contractors shall work together to assure that all equipment shall work safely, reliably under electromagnetic and electrostatic interference conditions where there are traction voltages such as 1500 Vdc and any other high voltage electrical sources including power cables running along the track. The system shall be designed to operate under the worst case interference conditions.
- 16.9.2 The CP NS-02 and CP NS-01 Contractor shall ensure that emissions and immunity levels of their respective equipment meet the requirements of IEC 62236 or equivalent standards.
- 16.9.3 The CP NS-02 Contractor shall ensure that the return current in the track at the specified frequencies, if any, does not exceed the values specified by the CP NS-01 Contractor.
- 16.9.4 The two Contractors shall also jointly develop a test plan detailing how the electromagnetic compatibility of the traction and signaling systems shall be verified. The two Contractors shall work together to assure that all electronic and electrical equipment on the Rolling Stock operates correctly without interfering with the signaling systems and vice versa.
- 16.9.5 The cable layout of the signaling systems in the cable ducts provided by the CP NS-02 Contractor shall be jointly agreed. The separation between signaling cables and power cables of 1500 Vdc, 440 Vac three-phase, 220 Vac single phase, 100 Vdc or any other similar higher voltage rating shall be in accordance with international practices.

16.10 Operational Modes

16.10.1 General

16.10.1.1 The following operational train modes shall be adopted for the line:

- a. Automatic Train Operation (ATO) Mode (for future use);
- b. Automatic Train Protection (ATP) Mode;
- c. Running-on-Sight (ROS) Mode;
- d. Restricted Manual (RM) Mode; and
- e. Cut-out Mode.

16.10.2 Automatic Train Operation (ATO) Mode

- 16.10.2.1 In ATO mode, the train shall operate without intervention by the train operator except when starting from a station stop. ATO automatically controls the train braking and traction systems under the supervision of the ATP system. In ATO mode opening of the train doors is automatic at stations. The train shall depart from the station after the train doors are detected 'closed' and the train operator has pressed the Start Button.
- 16.10.2.2 It should be noted that the train operations shall normally be performed using ATP in accordance with Grade of Automation 1 (GoA1). However, the system shall be upgraded to GoA2 when ATO over ETCS (AoE) standards are available already.

16.10.3 Automatic Train Operation (ATP) Mode

16.10.3.1 In ATP Mode the train will be driven by the train operator, obeying cab signals provided in the operator’s HMI. In ATP mode, the on-board signaling system shall provide cab signals and all other indications necessary to operate the train. Door opening and closing operation shall be carried out by the train operator.

16.10.4 Running-on-Sight (ROS) Mode

16.10.4.1 The ROS mode is selected by the train operator if the signaling system (on board or wayside) is not fully operational.

16.10.4.2 In ROS mode of operation, the Mode Selector Switch is in the ATP position and ROS mode is selected by a ROS button/key and the train operator runs on sight.

16.10.4.3 Maximum speed in ROS mode is 25km/h.

16.10.4.4 This mode remains in operation until sufficient conditions have been met to allow for a transfer to the ATP mode. However, the train operator will select the ROS signaling mode in certain cases (e.g. following an emergency brake application).

16.10.4.5 The ETCS Signaling System shall permit the train to transfer from ROS to ATP mode automatically without stopping the train, however the ROS mode can only be selected when the train is stationary.

16.10.5 Restricted Manual (RM) Mode

16.10.5.1 The RM mode is the default mode of operation in the Depot.

16.10.5.2 In Restricted Manual mode the train speed shall be limited to 25 km/h.

16.10.5.3 This mode shall be available only when the on-board signaling equipment is operational. RM mode shall also be utilized in the main line for coupling of trains for call-on or push-out train operations.

16.10.6 Cut-out Mode

16.10.6.1 In Cut-out mode, the train will be operated by the train operator in accordance with procedures and instructions from the Traffic Controller.

16.10.6.2 Cut-out mode is intended for use in the case of complete train-borne signaling-system failure preventing release of the emergency brake.

16.10.6.3 In Cut-out mode the Rolling Stock Contractor will ensure to limit the maximum speed to 25 km/h.

16.11 Interfacing Works on DMI

The NS-02 Contractor shall coordinate with NS-01 Contractor and also with CP04 Contractor to determine the suitable location of DMI (Driver Machine Interface) on the train’s dashboard. The Contractors’ shall consider only single DMI to optimize the driving console in the cab

16.12 Preparation for ATO and PSD controller

16.11.1 ATO will be installed in the future. Therefore, the above mentioned ETCS and some concerned devices shall be interfaced easily in consideration with the enough space, software, switch space, train lines, additional on-board antenna position, driver cab layout, speed sensor, CCTV and so on.

17 CCTV System

17.1 General

- 17.1.1 Four (4) cameras shall be installed in each car interior and shall be placed in the most optimum locations to capture the maximum view.

17.2 Monitoring and Memory

- 17.2.1 The camera images shall be transmitted by the Ethernet network in the Rolling Stock. For this transmission, the monitor transmission line shall be used and not the control transmission line.
- 17.2.2 When the Passenger Emergency Intercom (PEI) is activated, the driver shall be able to view nearby (several) camera image(s) of the activated PEI on TMS monitor in the driver’s cab in real time. In addition, the driver shall be able to select specific camera image(s) they want to view.
- 17.2.3 The data shall also be recorded onto the memory, meaning it can be viewed historically. As a minimum, high definition video quality and a week-long video memory capacity shall be provided.
- 17.2.4 The CCTV system shall be reviewed by the Engineer.

18 (Not Used)

19 General Documentation Requirements

19.1 General

- 19.1.1 All documents shall be written in the English language and all drawing in SI/metric units. Documents shall be made in a well-structured manner relevant to the car system.
- 19.1.2 All documents and drawings shall be supplied in electronic format, with the correct number of prints. Where special software is required in the use/access of the supplied documents/drawings, the corresponding software, all interface programs and hardware shall also be provided. All software/programs that have been custom-designed for this Project shall have no licensing restrictions.
- 19.1.3 All drawings furnished by the Contractor shall be in accordance with the guidelines to be provided by the Engineer, including but not limited to the following:

19.2 Drawing Submittals

- 19.2.1 All drawings shall conform to current industry standards. All drawings shall be supplied in electronic format, the specific format to be reviewed by the Engineer, and with the required number of prints;
- 19.2.2 The drawings submitted shall be of a quality capable of being reproduced clearly;
- 19.2.3 The drawing number and its revision level shall be clearly marked on the drawing; and
- 19.2.4 When revisions are made to drawings resulting in re-submittal, such drawings shall be accompanied by a covering letter detailing the changes made.

19.3 Drawings to be Submitted for Acceptance/Consent

- 19.3.1 All top-level assembly drawings of items installed on the car in the form of production drawings (dimensioned outline drawings may be considered acceptable upon review by the Engineer);
- 19.3.2 Wiring and interconnecting diagrams or tables for equipment, panels, assemblies and components, etc. requiring connection on the car;
- 19.3.3 Complete schematic diagrams for equipment and systems (electric, air, hydraulic, etc.);
- 19.3.4 Interface drawings (unless all interface information is contained on other drawings);
- 19.3.5 Assembly or outline drawings which show the details of mechanical attachment and electrical connection interfaces;
- 19.3.6 Switch logic diagrams (where appropriate);
- 19.3.7 Performance curves e.g. traction, braking and/or tabulations of equipment, systems, components, etc., and
- 19.3.8 Drawing tree, delineating all major drawings entering into the construction of the cars, and indicating construction and system logic.
- 19.3.9 The Employer through the Engineer reserves the right to review any/all drawings used in the design and manufacture of the cars.

19.4 General Format

- 19.4.1 All drawings shall be produced on standard sheet sizes and format as required in the General Requirements or as reviewed by the Engineer.
- 19.4.2 All drawings shall contain a title block containing the following minimum information:
 - a. Supplier company names;

- b. Drawing title (which shall not be ambiguous);
- c. Revision level of drawing, and date of revision (which must be updated for change and then be resubmitted for the Engineer's review);
- d. Scale, where appropriate;
- e. Number of sheets as "x" of "y"; and
- f. Date of released of drawing.

- 19.4.3 A table of revisions shall be provided for each drawing, which shall clearly show each revision level, the date, and the revision made.
- 19.4.4 A list of parts and required quantities shall be provided on each drawing, or as a separate bill of material.
- 19.4.5 A reference table shall be provided for product acceptance criteria.
- 19.4.6 The drawing shall comply with accepted drawing standards. The Contractor shall state which standard is used in their proposal and quotation.
- 19.4.7 Two clear areas shall be made available in the title block of the drawing for the Employer’s use.

19.5 Drawing Requirements

- 19.5.1 Drawings submitted shall conform to the following minimum requirements in relation to scope, content and format.
- 19.5.2 These requirements are not intended to restrict the presentation of information and shall be applied as appropriate to the equipment concerned.
- 19.5.3 Top Level Assembly/Outline Drawing:
- a. Scope to show equipment as supplied, in sufficient detail to determine basic specification compliance; and
 - b. Content Information.
- 19.5.4 As a minimum, the content information shall consist of:
- a. Important dimensions;
 - b. Mounting arrangements and their tolerances;
 - c. Panel, enclosure, frame, etc. construction, material, and finish;
 - d. Direction of rotation (where applicable), speed or frequency, and amount of unbalance;
 - e. Location of center of gravity, mass (in full working order), and mass carried at each mounting point;
 - f. Location and size of grounding straps or grounding facility;
 - g. Location of servicing features and clearance requirements for removal of all normal service items;
 - h. Labeling and location of notices and decals;
 - i. Special mounting instructions;
 - j. Equipment arrangements, including fastening hardware; and
 - k. List of parts, which must include the type number of devices as documented by the original manufacturer.

19.6 Electrical Information Requirements

- 19.6.1 Operating voltage, power consumption, power factor, and tolerances thereon;
- 19.6.2 Type of windings (for transformers and machines) and type of insulation;
- 19.6.3 Resistance and tolerances;
- 19.6.4 Contact ratings;
- 19.6.5 Operating parameters relevant to the type of device, type and size of cables and wires used;
- 19.6.6 Wire codes, and marking methods of wires and devices; and
- 19.6.7 Indication of color-coding of wire insulation (if used).

19.7 Schematic Diagram

- 19.7.1 As a minimum, the schematic diagram shall consist of:
 - 19.7.1.1 Scope to show in diagrammatic form how the subsystem equipment, printed circuit boards, etc. function, without regard to the physical location of the equipment or cable routing.
 - 19.7.1.2 Content Information:
 - a. All circuits contained within the equipment concerned;
 - b. Wire identification code numbers;
 - c. Car builder/supplier interface terminal code numbers and connector pin numbers;
 - d. Trip/rupture current values of all protective devices;
 - e. Settings of all pressure, temperature, vacuum float, limit switches, time delay relays, etc. with tolerances;
 - f. Values and tolerance of passive components;
 - g. Load power consumption;
 - h. Circuit voltages (nominal);
 - i. Terminal code numbers on polarity sensitive components and subsystems for which a separate schematic is provided; and
 - j. Control logic charts and sequence diagrams.
- 19.7.2 Electrical symbols on schematics and wiring diagrams shall comply with accepted standards. The Contractor shall state in their proposal which standard is used, subject to the Engineer’s review.

19.8 Drawings and Design Data Changes

- 19.8.1 Prior to the qualification tests, the Contractor must notify the Engineer of any design changes.
- 19.8.2 After the First Article Configuration Inspection (FACI) is given Notice of No Objection, any change to any part must be submitted to the Engineer for review, together with an assessment of its impact on performance, reliability and interchangeability.

19.9 Engineering Documentation

- 19.9.1 The Contractor shall furnish three (3) copies in electronic format and all required prints of the latest revision of all necessary contract drawings and documents. Thereafter, the Contractor shall update all subsequent revisions to these documents and shall submit three (3) copies in electronic format and all required prints of all revisions of these controlled documents to the Engineer for review.
- 19.9.2 The Contractor shall provide six (6) copies in electronic format and six (6) copies of prints of the as-built drawings.

19.10 As-Built Car Specification

- 19.10.1 The Contractor shall be required to provide an electronic copy and six (6) hard copies of this ERT, updated and modified to reflect the as-built specifications of the train.

19.11 Maintenance Manuals

19.11.1 General

- 19.11.1.1 A fully integrated maintenance manual shall be provided, which shall provide step-by-step instructions on how to maintain, repair and replace all components on the cars, down to the Lowest Line Replaceable Unit (LLRU) and working time required for various maintenance activities. It shall be assumed that the technicians performing this work have familiarity with rail cars, but not a detailed working knowledge. The LLRU shall be defined, as any component within an assembly that is identified in the Original Equipment Manufacturer’s (OEM) illustrated parts catalogue and/or is offered for sale by the original equipment manufacturer.
- 19.11.1.2 The maintenance manual shall provide all necessary details to perform the work required, and shall include the judicious use of diagrams, drawings, colored photographs, illustrations, etc., as appropriate for the tasks at hand, including necessary safety precautions. Detailed maintenance and troubleshooting procedures and test and repair procedures shall be provided for all electronic assemblies and circuit boards. Manuals shall identify all tools (special and standard) needed to perform the work. This listing of tools shall be provided in the appropriate Sub-Clauses describing the discrete tasks being performed.
- 19.11.1.3 All manuals shall be provided in electronic format, and six (6) prints of properly bound oil and dirt resistant hard copies. The material for the hard copies shall be reviewed by the Engineer.
- 19.11.1.4 The maintenance manuals shall be divided into three parts:
- a. Running maintenance manual;
 - b. Scheduled maintenance manual; and
 - c. Overhaul manual.

19.11.2 Running Maintenance Manual

- 19.11.2.1 The running maintenance manual shall describe all work and inspections to be performed on the trains on a routine basis, including servicing, lubrication, adjustments, problem diagnosis, etc.
- 19.11.2.2 Recommended cleaning procedures shall be provided, including necessary cleaning solutions. A substantial troubleshooting and repair guide shall be included to streamline the process of finding the root cause of problems and providing resolution.

19.11.3 **Scheduled Maintenance Manual**

- 19.11.3.1 The scheduled maintenance manual shall describe all work and inspections to be performed on the trains according to pre-set time periods or accumulated km-run and per sub-system structure (i.e. body, bogie, propulsion, auxiliary, ACU, pneumatics, braking, etc.).
- 19.11.3.2 An appropriate troubleshooting guide and/or parts repair /replacement shall be provided.

19.11.4 **Overhaul Manual**

- 19.11.4.1 The overhaul manual shall describe all work and inspections to be performed on the trains at designated overhaul periods or accumulating certain number of km-run.
- 19.11.4.2 An appropriate troubleshooting guide and/or parts repair/replacements shall be provided.

19.11.5 **Illustrated Parts Catalogue**

- 19.11.5.1 The Illustrated Parts Catalogue (IPC) shall enumerate and describe all assemblies and constituent components down to the LLRU.
- 19.11.5.2 The IPCs shall be internally arranged in a logical fashion, by system, and shall identify the Contractor’s part number and the OEM part number. Additionally, the Contractor shall provide the pertinent information on at least two different alternative suppliers for non-proprietary all components. Suppliers must be given Notice of No Objection according to the Engineer’s review.
- 19.11.5.3 Parts common to different assemblies shall bear the same Contractor number. The next level assembly of all parts shall be clearly identified.
- 19.11.5.4 The judicious use of cutaway isometric and exploded drawings, photographs, illustrations, etc., shall be used to clearly identify all components down to the LLRU.
- 19.11.5.5 Six (6) copies of the IPCs shall be provided in electronic and interactive format, along with six (6) properly bound oil and dirt resistant hard copies. The Illustrated Parts Catalogue shall be reviewed by the Engineer.

19.11.6 **Operator Manual**

- 19.11.6.1 The Contractor shall provide six (6) sets of properly bound, oil and dirt resistant hard copies of operator manual, which shall contain all information required for the proper operation of the cars. This shall include general car familiarization material and the location, function and operation of all controls, switches, indicators, gauges, etc.
- 19.11.6.2 The operator manual shall also be provided in electronic format, six (6) sets hard copies. The Operator Manual shall be reviewed by the Engineer.

19.11.7 **Training Material**

- 19.11.7.1 Attention is drawn to the requirements of ERG Sub-Clause 14 - Training. The Contractor shall provide six (6) sets of all material used to train the personnel to operate and maintain the cars.
- 19.11.7.2 The training material and the entire training program shall be reviewed by the Engineer.
- 19.11.7.3 The training materials shall also be provided in electronic format and six (6) sets of hard copies.

19.11.8 Car History Books

19.11.8.1 The Contractor shall provide a car history book for each car at the time of delivery and acceptance. Each car history book shall contain, but not be limited to, the following car-specific information:

- a. Certified weight (car and axle loads), including scale tickets;
- b. Results summary of all tests performed on the complete car and its systems and subsystems, including certification performed where required;
- c. A set of test results for each component or system where these are required;
- d. A description of each configuration change from the base-line in sufficient detail for the Engineer’s understanding;
- e. Configuration record of each assembly, sub-assemblies and major components, including revision number and dates;
- f. List of defects noted, status and disposition;
- g. List of serial-numbered equipment;
- h. List of “as built” drawings with revision status;
- i. Axle assembly (wheels, bearings, gears) mounting records, including pressing charts;
- j. Provision for the service to record inspection, servicing, overhaul and repair activities; and
- k. Shipping documents.

19.11.8.2 The Contractor shall supply in electronic format and in six (6) hard copies of properly bound oil and dirt resistant hard copies for each car, the full history and configuration records, arranged by component type, assembly, sub-assembly, major component and other serial-numbered components, including spares, test equipment and special tools. The car history book format shall be reviewed by the Engineer.

19.11.9 Intervention/Modifications History Record (Defects Notification Period)

19.11.9.1 The Contractor shall provide a supplemental history record for each car at the time of final acceptance/after the DNP. Each supplemental history record shall contain the following car-specific information:

- a. Intervention and repairs during DNP;
- b. All modifications/revisions done during DNP;
- c. All tests/validation test reports and records; and
- d. All component exchange and new numbers.

19.11.9.2 The intervention/modification history record shall be provided in electronic format, and six (6) sets of hard copies of properly bound oil and dirt resistant. The intervention/modification history record format shall be reviewed by the Engineer.

20 Inspection, Testing and Commissioning

20.1 Inspection

20.1.1 General

- 20.1.1.1 The Engineer shall have free access to the Contractor’s premises throughout the Contract, for the purpose of reviewing and inspecting the design and manufacturing processes.
- 20.1.1.2 The Contractor shall extend to the Engineer or their nominee, full cooperation and provide facilities at its premises and final assembly site to enable convenient inspection of materials, work and equipment.
- 20.1.1.3 To initiate this process the Contractor shall arrange for some orientation meetings, whereby the Engineer and Employer shall attend their premises for discussions leading to greater mutual understanding of the Contract.
- 20.1.1.4 The Contractor shall bear the cost of attendance in line with that stated in Sub-Clause 20.1.2.4.
- 20.1.1.5 It is anticipated, that the level of support will in accordance with that shown in Table 20.1, below.

Table 20.1 Orientation Trips

No.	Attendance	Quantity	Remarks
1	Employer	2 roundtrips*7 days*2 persons	Orientation
2	Engineer	2 roundtrips*7 days*5 persons	

- 20.1.1.6 Copies of all design data shall be provided. Design data shall be sufficient to enable the Engineer to review the design, construction, assembly, installation, workmanship, clearance, tolerances, and functioning of all Works. The Engineer shall have unrestricted rights of inspection of all documents, tools, and test equipment to be delivered to the Engineer as part of the Works.
- 20.1.1.7 The Engineer shall be at liberty to inspect the manufacturing process at any stage. Without prejudice to any other provision of the Contract, the Engineer reserves the right to reject all materials and workmanship which do not fully conform to this ERT. Repetitious rejections at either a subcontractors’ or Contractor’s facilities shall be cause for the Engineer to suspend inspection. In such case, the work in question shall also be suspended until satisfactory corrective action is taken by the Contractor.
- 20.1.1.8 The Engineer shall have unrestricted rights of inspection of all documents, tools and test equipment.

20.1.2 Inspection Hold Points

- 20.1.2.1 The Contractor shall propose a structured set of inspection hold points. The hold points shall be structured so that a formal hold point is allowed for each significant element of the car’s manufacturing process. At each hold point the Engineer shall hold a formal inspection, or advise that the inspection has been waived;
- 20.1.2.2 The construction of each car shall not proceed until the inspection by the Engineer has been completed or waived;
- 20.1.2.3 The Contractor shall propose the inspection hold points within 180 days of the date for commencement of the Works. The inspection hold points shall be submitted for review by the Engineer;

20.1.2.4 No Rolling Stock shall be considered ready for delivery without the Engineer’s endorsement in writing. The Contractor shall bear the cost of attendance at the inspections/tests made outside the Country including travel, flight charge (economy class) from Manila to the place where the inspection/test will be made, lodging, local transportation, safety gears, insurance, per diem allowance of \$100 US each upon landing until the last day of stay on the country of destination, etc., for the Employer’s and Engineer’s Personnel (attendance). It is expected that five (5) attendances will attend at each inspection/test at seventy-six (76) times with seven (7) days including travel time for each inspection/test as shown in Table 20.2. If the inspection/test cannot be completed satisfactorily, the additional inspection/test attended by attendance will be arranged and the cost of attendance for such additional inspection shall be borne by the Contractor;

Table 20.2 Inspection Trips

No.	Attendance	Quantity	Remarks
1	Employer	76 roundtrips*7 days*3 persons	Type test, FAT, I FAT and FACI
2	Engineer	76 roundtrips*7 days*2 persons	

20.1.2.5 The Contractor shall submit the inspection/test procedure for Engineer review ninety (90) days prior to the commencement of the respective inspection/test activity;

20.1.2.6 The Contractor shall prepare and submit to the Engineer for review two (2) copies of inspection or test report immediately after the completion of each inspection or test;

20.1.2.7 Once the inspection/test and any required remedial actions are completed to the satisfaction of the Engineer, the Engineer shall give a notice of endorsement for unit shipment; and

20.1.2.8 Any unit delivered without the Engineer’s endorsement may be rejected at the Site and all expenses thereby incurred shall be borne by the Contractor.

20.1.3 Inspection Prior to Delivery

20.1.3.1 The Engineer/Employer shall be afforded the opportunity of inspecting all cars to be delivered under the Contract before leaving the Contractor’s facility and prior to delivery to the Site;

20.1.3.2 The Contractor shall advise the Engineer no less than 15 days in advance of a car being available for inspection; and

20.1.3.3 Once the inspection and any required remedial actions are completed to the satisfaction of the Engineer, the Engineer shall give consent for car shipment.

20.2 General Testing Requirements

20.2.1 General

20.2.1.1 The Contractor, in addition to testing for design verification purposes, shall carry out all testing of cars to ensure and demonstrate that the train consist and all its equipment is safe, functional and suitably reliable for revenue service.

20.2.1.2 The Contractor shall be responsible for all materials, consumables, test equipment, labor and facilities for the test, unless specified differently in writing by the Engineer.

20.2.2 Test Plan

- 20.2.2.1 The Contractor shall, within 90 days of the date for commencement of the Works, submit for review and concurrence by the Engineer an Inspection, Testing and Commissioning Plan outlining categories and the general quantity of tests to be carried out and approximate schedule of testing;
- 20.2.2.2 The Inspection, Testing and Commissioning Plan shall be submitted in accordance with the requirements of the ERG Sub-Clause 1.7.7. The Inspection, Testing and Commissioning Plan shall be separated into two major categories: the Factory Acceptance Test (FAT) and the on-site testing and commissioning;
- 20.2.2.3 For the submission of the Inspection, Testing and Commissioning Plan, the Contractor shall combine the requirements of design qualification testing, First Article Configuration Inspection, Factory Acceptance Test, on-site testing and commissioning and Trial Operations into one single plan, if appropriate;
- 20.2.2.4 The Contractor shall, within 180 days of the date for commencement of the Works, submit for review by the Engineer an updated version of the Inspection, Testing and Commissioning Plan detailing:
 - a. All tests to be carried out;
 - b. Scheduled test dates;
 - c. Location of the test;
 - d. Function to be tested and requirement to be demonstrated; and
 - e. Party responsible for the testing.
- 20.2.2.5 Without prejudice to any other provisions of the Contract, the Engineer reserves the right to witness any or all tests, and to require submission of any or all test specifications and reports. The Engineer reserves the right to reasonably call for additional tests if considered necessary;
- 20.2.2.6 The Contractor shall reissue the Inspection, Testing and Commissioning Plan monthly thereafter, updating all information as test scheduling is confirmed and tests are carried out, annotating which tests the Engineer shall witness and which test reports shall be submitted. No test date shall be changed without the Engineer having a minimum of 15 days’ notice; and
- 20.2.2.7 The Contractor shall within 90 days of the substantial completion of the Works submit for review a Commissioning Plan Compendium, recording all testing carried out, functions and performance demonstrated, reports produced and reviewed by the Engineer. This shall include all System Performance Demonstrations.

20.2.3 Testing Details

- 20.2.3.1 For any tests where the Engineer has indicated that they wish to witness, no testing shall be carried out against a test specification prior to its review by the Engineer;
- 20.2.3.2 The test specification shall include sample test certificates, design values and also the tolerances;
- 20.2.3.3 All materials and/or details represented by samples, which are found to be non-compliant, shall be rejected; and
- 20.2.3.4 The Contractor shall replace any material or detail destroyed in the process of testing.

20.3 Design Qualification Testing

- 20.3.1 As part of the design verification process, type tests shall be carried out to demonstrate that the design of the train consist and its systems are in full compliance with the requirements specified in this ERT. The tests shall be completed at the Contractor’s manufacturing facility unless otherwise specified or reviewed by the Engineer;
- 20.3.2 The Contractor shall perform an endurance test in accordance to the requirements of ERT Sub-Clause 7.1 - Passenger Side Entrance Doors on the proposed door design to demonstrate that the requirements specified therein are met;
- 20.3.3 The door system shall be endurance tested on a rig in suitable climatic conditions to demonstrate that the door system shall allow the train consist to meet the requirements of this ERT. The rig shall test opening and closing of the door, obstruction detection and re-opening of the door in a combination to simulate likely service operation and shall be submitted for review by the Engineer;
- 20.3.4 Design qualification testing shall be performed on the complete propulsion, braking and TMS systems configuration, using simulated loads on the traction motors. Combined propulsion system testing shall be in accordance with IEC 61287-1 and IEC 61377 or equivalent;
- 20.3.5 Design qualification testing shall be performed on the complete auxiliary power system configuration, using simulated loads. Combined auxiliary power system testing shall be in accordance with IEC 61287-1 or equivalent;
- 20.3.6 Design qualification testing shall be performed for the TMS system to verify designed capacity of the systems, functional requirement and correct interfacing. The real interface hardware and software shall be used where possible;
- 20.3.7 The braking system shall be tested to demonstrate its ability to satisfactorily interface with the train control and signaling systems, and provide performance as specified herein;
- 20.3.8 The parking brake shall be tested to demonstrate its ability to hold a consist on the specified gradient. The test shall record the actual force required to overcome the parking brake in a failure recovery situation on both level track and a 3.5% gradient. The test shall be undertaken at the time of handing over of the Rolling Stock;
- 20.3.9 Before transporting the Rolling Stock to Manila, the Contractor shall perform a test to demonstrate that the emergency and service braking requirements have been met for each design deceleration;
- 20.3.10 The Contractor shall prepare and conduct qualification tests to demonstrate that all other equipment to be supplied shall operate properly within the limits of the environmental and/or physical parameters listed in this ERT. The test shall be undertaken at the time of handing over of the Rolling Stock at the depot; and
- 20.3.11 Running resistance and an energy consumption test shall be conducted during type test.
- 20.3.12 Any design changes, adjustments, etc., that are required to meet the performance requirements, shall be fully re-tested and documented. All equipment design changes shall be subject to prior review by the Engineer.
- 20.3.13 For any unit previously qualified, or with a railroad proven service history, the Contractor may request a waiver from performing the qualification test. However, the request for a waiver must be accompanied by a duplicate test report or certification for review by the Engineer in order to satisfy qualification requirements. The waiver request must include justification of the claim that the equipment and test(s) are substantially the same as those in the current qualification requirements.
- 20.3.14 Only with the written consent of the Engineer shall qualification testing or certification requirements be waived.

20.4 Acceptance Testing

20.4.1 General

- 20.4.1.1 All cars, sets and consists shall undergo acceptance testing in accordance with the requirements of IEC 61133 or accepted equivalent as a minimum.
- 20.4.1.2 Acceptance tests shall be completed on every car supplied under this Contract to prove that manufacturing and assembly of the trains have been carried out appropriately.
- 20.4.1.3 A type test shall be conducted for the first 8-car train set and a routine test shall be completed on every trainset after that.
- 20.4.1.4 The tests shall be completed at the Contractor’s manufacturing facility as a Factory Acceptance Test (FAT) and on-Site after delivery of the train as on-Site testing and commissioning.

20.4.2 Factory Acceptance Test (FAT)

- 20.4.2.1 The Contractor shall perform a FAT to ensure that the various train systems are functioning correctly before shipment of the trains.
- 20.4.2.2 The tests shall be conducted in the test track and any other special test facilities of the Contractor.
- 20.4.2.3 The following tests shall be carried out as a minimum but not limited to:
- 20.4.2.4 Type Test: These tests shall be performed on the 1st trainset:
 - a. Dimension inspection;
 - b. Weighing; and balancing the car weight over all eight (8) wheels;
 - c. Dielectric test;
 - d. Brake system test;
 - e. Auxiliary power supply operation;
 - f. Door system operation;
 - g. Air conditioning operation;
 - h. Water tightness test.
 - i. Propulsion system test;
 - j. Bogie car clearance test (one motor car and trailer car only);
 - k. Car body loading test (one car only);
 - l. Jacking up test;
 - m. Center of gravity measurement;
 - n. Interior lights illumination test;
 - o. Noise measurement (static);
 - p. Vibration measurement; and
 - q. On-board signaling function test.
- 20.4.2.5 Routine Test: These tests shall be performed on the 2nd to 38th trainset:
 - a. Dimension inspection;
 - b. Weighing; and balancing the car weight over all eight (8) wheels;
 - c. Dielectric test;

- d. Brake system test;
- e. Auxiliary power supply operation;
- f. Door system operation;
- g. Air conditioning operation;
- h. Water tightness test; and
- i. Propulsion system test.

20.4.3 **Integrated Factory Acceptance Test**

20.4.3.1 Integrated Factory Acceptance Test (IFAT) to verify the integration of the Rolling Stock with E&M systems; the minimum IFAT being:

- a. Rolling Stock – signaling system (wayside / on board); and
- b. Rolling Stock – Communications.

20.4.3.2 The CP NS-02 and CP NS-01 Contractors shall provide an Integrated Factory Acceptance Test plan, to be submitted to the Engineer for recommendation. This shall be the responsibility of the CP NS-01 Contractor.

20.4.3.3 The minimum integrated interface tests to be carried out include the following:

- a. Integrated Factory Bench Test (IFBT) to verify communication and protocols between the electronic control units of the CP NS-02 Contractor and the CP NS-01 systems. This test is to be carried out in the designated factory of the CP NS-02 Contractor;
- b. Static integrated factory interface test (SIFIT) to verify the satisfactory mechanical and electrical integration of the train control on-board and the wayside equipment. This test is to be carried out in the designated factory of the CP NS-02 Contractor and supported by the CP NS-01 Contractor.
- c. Dynamic Integrated Interface Test (DIIT) shall be carried out to verify train characterization, response times, stopping distances, stopping accuracy, train control functions, communications and operating modes. This test is to be carried out at the designated test track of the CP NS-02 Contractor and shall include for the provision of interfacing systems of the CP NS-01 Contractor e.g. Signaling, Communications, Power, OCS, etc.

20.4.4 **On-site Testing and Commissioning**

20.4.4.1 During on-site testing and commissioning of the 8-car consists, the following inspections and tests, as a minimum but not limited to, shall be carried out to demonstrate functions. On-site commissioning shall be considered as the completion tests to be performed by the Contractor under the Contract.

- a. Post Delivery inspection;
- b. TMS operation;
- c. Performance acceleration to set speeds;
- d. Air system integrity;
- e. Air system protective devices;
- f. Parking brake integrity;
- g. CCTV integrity;
- h. Performance of emergency brake from set speeds;
- i. Blended pneumatic and regenerative braking from set speeds;

- j. Train radio operation;
 - k. Public Address system operation;
 - l. Lighting operation;
 - m. Air conditioning operation;
 - n. Passenger information display operation;
 - o. Cab controls, functions and indications;
 - p. Door control and functionality, per door and all doors;
 - q. Signaling system operation;
 - r. Safety critical functions; and
 - s. Any other routine test demonstrating fulfilment of the requirements of the interface specifications.
- 20.4.4.2 Commissioning shall be carried out on all consists supplied under this Contract. For each consist delivered to the Site, the Contractor shall establish an open actions list. The open actions list shall record all actions to be carried out on the train consist, and shall be supplemented as additional actions become known. These shall include:
- a. Type, routine, integration and commissioning tests;
 - b. Fault correction and equipment repairs; and
 - c. Fleet modifications and defect rectification.

20.5 (Not Used)

20.6 Test Documentation

20.6.1 All test documentation, procedures, reports and certifications shall be provided with a unique document number and be subject to formal document control procedures.

20.6.2 Test Procedures

20.6.2.1 The test procedure must state the purpose of the test, and reference the relevant portion of the ERT or standard with which the procedure aims to comply. The test procedure shall clearly define the condition of the equipment and the test set-up (test conditions), and any tests that the equipment must have previously passed. The test procedure must describe in detail the equipment needed to perform the test.

20.6.2.2 The test procedure must provide detailed, step-by-step instructions as to how the test is to be carried out. This includes results expected and actions to be taken if the expected results are not achieved.

20.6.2.3 The test procedure shall define the data to be recorded.

20.6.3 Test Reports

20.6.3.1 The test report(s) shall identify the test procedures in accordance with which the tests were performed, and the reason for performing the tests.

20.6.3.2 The test report(s) shall describe the specific test conditions encountered compared to those required by the test procedure. If there are any differences, shall be highlighted.

- 20.6.3.3 The test report shall provide a detailed description as to how the test was performed, clearly stating if any steps were different than specified, and describing the differences. The test report must provide a rational explanation for any deviations from the procedure.
- 20.6.3.4 The test report shall clearly detail the results obtained, and discuss the results in context with those expected.
- 20.6.3.5 The test report must provide a conclusion as to whether the test passed or failed.

20.7 Integrated Testing and Commissioning

- 20.7.1 During Integrated Testing and Commissioning of the railway, the CP NS-01 is the lead Contractor responsible for the tests plans, monitoring and test reports, with all interfacing Contractors supporting these activities accordingly.
- 20.7.2 The CP NS-02 and the CP NS-01 Contractors shall coordinate and submit the following Integrated Testing and Commissioning (ITC) deliverables:
 - a. Production of an ITC plan, for inspection and testing of equipment that interfaces with other contracts;
 - b. Coordination with interfacing parties regarding the requirements relating to interface testing;
 - c. Production of a test schedule of tests, providing full details of all tests to be carried out under the Contract; and
 - d. Testing procedures to be presented to the Engineer for review.

20.8 Trial Operations

- 20.8.1 The objective of Trial Operations, is that operational readiness is verified, meaning that full training of operational staff including drivers, emergency-service personnel and others, has taken place successfully, demonstrating that the required railway operational safety, together with the requisite performance criteria in the employer’s requirements, has been achieved.
- 20.8.2 The Contractor shall support the Employer during the Trial Operations which shall take place at the completion of the Testing and Commissioning.
- 20.8.3 The Trial Operations consist of operating the newly procured trains, taking into consideration requirements of operating the trains for revenue service, but without passengers.
- 20.8.4 The objectives of the Trial Operations shall include, but is not limited to:
 - a. Validation of all interfaces with the on-board signaling system;
 - b. Validation of train schedule running;
 - c. Training of drivers, OCC staff and line managers; and
 - d. Emergency exercises.
- 20.8.5 Different test cases shall be developed in normal operation (checking that new trains can achieve daily timetable without delays and incidents) and degraded modes (simulating different incidents) as follows:
 - a. Failure during pre-departure tests;
 - b. Traction mode failure;
 - c. Train doors fail to close;
 - d. On-board signaling defects; and
 - e. Rescue of Failed Train.

- 20.8.6 A detailed list of test cases shall be drafted by all interested parties prior to the commencement of the Trial Operations. Some of these tests may be an opportunity for close-coordination with third parties such as the police and emergency services, to check any new features of the procured new trains.

21 Material and Workmanship

21.1 General

- 21.1.1 All materials used in the construction of the Project shall be new, of first-class quality, consistent with materials commonly used in rail car manufacture. All workmanship shall be high quality and shall conform to the best manufacturing practices in all respects.
- 21.1.2 All materials, specialties, equipment component parts, and accessories shall be manufactured in accordance with, and shall comply with, the standard or specification of the appropriate national technical or professional society or trade association or Government Agency, to ensure compliance.
- 21.1.3 All materials shall be marked or stored to be readily identified and shall be adequately protected during handling and storage.
- 21.1.4 Environmentally harmful materials shall be avoided in the design and manufacturing of the car. This shall include but not be limited to the following materials and chemicals:
 - a. Ozone depleting Freons;
 - b. Polychlorinated Biphenyls;
 - c. Brominated Flame retardant;
 - d. Formaldehyde;
 - e. Halon;
 - f. Beryllium;
 - g. Lead;
 - h. Cadmium (except in recyclable batteries);
 - i. Isocyanates;
 - j. Asbestos; and
 - k. Urethane foam.

21.2 Fasteners

- 21.2.1 All screws, bolts, nuts and washers shall be in metric configuration and conform to applicable standards and shall be zinc plated, unless stainless steel.
- 21.2.2 All fasteners of 4 mm diameter or larger shall have coarse threads, except as specified. Exceptions may be permitted, but require review by the Engineer.
- 21.2.3 All hardware used shall be of the same grade, and shall be at least one grade higher than the stress limit required. Exceptions may only be permitted after review by the Engineer.
- 21.2.4 Bolts used with nuts shall be the shortest standard size that shall provide at least two full threads through the nut. All high strength bolts and cap screws shall have the head marked to indicate grade. All high strength nuts shall be marked to indicate grade. All bolts, nuts, cap screws and machine screws shall be locked to prevent loosening in service. The locking method shall be subject to the Engineer's review.
- 21.2.5 The threads of stainless steel fasteners shall be suitably treated to prevent galling upon installation. All wire ties used shall be of the weather-resistant (black) variety.

21.3 Parts

- 21.3.1 Components, plates, shields, or other parts, which may be removed for repair or maintained, shall be interchangeable with other identical items.
- 21.3.2 Non-maintained components shall be designed for a useful life of 30 years. If, during the warranty period, it is demonstrated that the extrapolated life of any component is less than 30 years, the component must be redesigned and replaced on every car.
- 21.3.3 All parts shall be free from sharp edges and burrs that might injure persons or damage clothing.

21.4 Electrical Components

21.4.1 Terminals

- 21.4.1.1 Solderless terminals shall be submitted for the review of the Engineer and given Notice of No Objection equivalent and shall have sufficient current carrying capacity, de-rated to the anticipated maximum operating temperature.
- 21.4.1.2 The use of quick connect ("FASTON") terminals shall not be allowed, except subject to review by the Engineer. When allowed, quick connect terminals must be of brass or phosphor bronze.
- 21.4.1.3 Only ring tongue terminals shall be used, except as specifically reviewed and commented by the Engineer.

21.4.2 Wire Insulation

- 21.4.2.1 Unless otherwise specified, wire insulation shall be one of the following types, unless specifically reviewed by the Engineer:
 - a. Ethylene Tetrafluoroethylene (ETFE) fluoropolymer having a continuous temperature rating of 150 °C;
 - b. Abrasion resistant, filled Tetrafluoroethylene (TFE) with a temperature rating of 260 °C;
 - c. Cross-linked Polyolefin (XLPO);
 - d. All wire insulation, except car body wiring, shall be rated at 600 V minimum; unless otherwise specified or agreed to by the Engineer. Car body wire insulation shall be rated at 2000 V minimum; and
 - e. Wires 6 mm² and smaller shall have the appropriate insulation material as defined above. Wires larger than 6 mm² shall be insulated only with cross-linked Polyolefin (XLPO).

21.4.3 Wire Current Rating (Ampere Capacity)

- 21.4.3.1 The selection of wire sizes and insulation shall be based on the current carrying capacity, voltage drop, mechanical strength, expected maximum operating temperature and flexibility requirements in accordance with applicable rail industry approved standards.
- 21.4.3.2 Maximum wire current rating shall conform to applicable rail industry approved standards. Where conductors are routed in a raceway or cable, the current rating shall be suitably de-rated.

21.4.4 **Wire Stranding**

- 21.4.4.1 Wire stranding and conductor construction shall be appropriate for the application, taking into account wire size, flexing requirements, etc., and shall comply with appropriate rail industry approved standards.

21.4.5 **Wiring Prohibition**

- 21.4.5.1 Pinch screw terminals and solid conductors are specifically forbidden.

21.4.6 **Creepage and Clearance**

- 21.4.6.1 Electrical creepage and clearance shall be adequate for the voltage levels and environment.

21.4.7 **Insulation Resistance**

- 21.4.7.1 The insulation resistance of all wiring shall be designed and tested in accordance with industry approved insulation resistance test and high potential test procedure.

21.4.8 **Voltage Segregation**

- 21.4.8.1 Wires shall be segregated into separate bundles/harnesses and connectors according to the voltage ratings in the following classes:
- a. Line voltage DC wiring;
 - b. Low voltage AC wiring (Under 600 V);
 - c. Battery voltage wiring (Under 125 V);
 - d. On-board signaling system wiring; and
 - e. Radio, Intercom, P/A wiring.

21.5 **Electronic Equipment**

- 21.5.1 As a minimum, all electronic equipment shall comply with Electronic Equipment for Rolling Stock (JIS E 5006) (or other equivalent standards) for design manufacture and testing and shall use components purchased against an internationally recognized quality.
- 21.5.2 Electronic components shall only be purchased from suppliers with a minimum Quality Management System (ISO 9001/2) certification or equivalent.
- 21.5.3 Electronic equipment shall meet the requirements for radio frequency interference and electromagnetic compatibility as required in ERT Sub-Clause 1.12.1.

21.6 **Mechanical Provisions**

21.6.1 **Metals**

- 21.6.1.1 Metals shall be supplied in compliance with the following material standards or equivalent:
- a. Stainless Steel JIS G 4305
 - b. Aluminum and Aluminum Alloy Sheets (JIS H 4000); and
 - c. Painted and Baked Aluminum and Aluminum Alloy Sheets (JIS H 4001).

21.6.2 Welding

- 21.6.2.1 All welding procedures shall be documented by the Contractor. Approval of the welding procedures shall be as required by JIS E 4047 – design method for arc welding joints of steel for railway Rolling Stock or other equivalent standards.
- 21.6.2.2 The Engineer reserves the right to require the quality of individual welds, particularly in critically stressed areas, to be verified by an approved Non-Destructive Testing (NDT) procedure.

21.7 Paints, Coating and Protection

- 21.7.1 All surfaces shall be completely free of rust, scale, grease and other foreign material immediately before painting and shall be painted with at least two coats of primer and one finish coat of paint.
- 21.7.2 Areas exposed to corrosive fluids or cleaning solutions shall be protected with coatings resistant to those fluids.
- 21.7.3 The finish coat shall match that of the equipment in quality and color. There shall be no paint applied to hoses and electrical lines.
- 21.7.4 The interior surfaces of equipment enclosures shall be primed and given one coat of insulating paint.
- 21.7.5 There shall be no exposed, unpainted or untreated surfaces on the equipment supplied unless specifically reviewed by the Engineer.

21.8 Fire Safety

- 21.8.1 The Contractor shall make every possible effort to ensure that all materials used in the construction of the equipment supplied have properties that are not conducive to the propagation of flame, nor to the generation of smoke and toxic gases, consistent with the properties required to perform the service intended.
- 21.8.2 The Rolling Stock shall comply with all relevant requirements in the Japanese Ministerial Ordinance, MLIT Chapter 8, Article 83 (Countermeasures for Fire of Rolling Stock) or other equivalent standards.
- 21.8.3 The Contractor shall provide data pertaining to all relevant tests having been performed on the materials to be used.
- 21.8.4 The Employer reserves the right to request the Contractor to prove compliance to this specification.

21.9 Equipment Enclosures

- 21.9.1 All equipment enclosures installed in locations exposed to outside ambient conditions shall be designed and manufactured to prevent the entry of foreign substances, such as liquids (including water, spilled drinks, car wash over spray, and wheel splash), dust and dirt, oil, or debris.
- 21.9.2 Enclosures shall be made to IP 55 rating or better.
- 21.9.3 Enclosures containing equipment, which may produce gases (such as battery boxes), shall be designed and manufactured to ensure that the gases are safely exhausted to outside the enclosure.

21.10 Security, Anti-Social Behavior and Vandalism

- 21.10.1 The car shall be capable of being made secure when stabled without compromising the need to maintain accessibility for emergencies.
- 21.10.2 The design of the interior body side windows and glazed surfaces shall optimize passenger safety in all foreseeable circumstances.
- 21.10.3 The modular interior shall be sufficiently robust to minimize damage from foreseeable vandalism and misuse.
- 21.10.4 Tamper-proof fixing arrangements shall be fitted where necessary. Fasteners shall not be visible or accessible to passengers as far as is practicable.
- 21.10.5 All interior body side windows and glazed surfaces shall incorporate a means to minimize the damage from vandalism, by etching or scratching.
- 21.10.6 Internal and external finishes shall permit the easy removal of graffiti by trained personnel using proprietary graffiti cleaning chemicals, and the surfaces shall not readily degrade as a result of the removal process.
- 21.10.7 The modular interior shall be free from gaps and crevices where litter, sharp objects or any other items could be concealed or lodged. Any equipment fitted behind seats shall be adequately designed to eliminate gaps or hidden voids.
- 21.10.8 Soft furnishings shall be resistant to damage by sharp objects and be designed to be economical and easy to replace when deemed necessary.
- 21.10.9 All modular interior equipment within the passenger areas shall be resistant to vandalism.

22 Project Management Requirements

22.1 General

- 22.1.1 As required in ERG Sub-Clause 1.7.5, the Contractor shall submit a Project Management Plan for the Engineer’s review.
- 22.1.2 In addition, the Contractor shall submit the Detailed Works Programs (Project Implementation Program) as required in ERG Sub-Clause 1.7.8 of General Requirements.

22.2 Engineering Schedule and Reviews

- 22.2.1 It shall be the responsibility of the Contractor to promptly advise the Engineer of any anticipated delays in drawing or document submittal, with the reason for such delays, so that the impact may be assessed, and appropriate measures taken.
- 22.2.2 At a minimum, design reviews must be conducted on all of the following major systems:
- i. On-board signaling equipment interface;
 - ii. Auxiliary Power Supply Equipment (APSE);
 - iii. Battery;
 - iv. Bogies;
 - v. Braking equipment, including air compressor;
 - vi. CCTV system;
 - vii. Car body structure;
 - viii. Air compressor;
 - ix. Car interior arrangement;
 - x. Car roof layout;
 - xi. Car underfloor layout;
 - xii. Couplers;
 - xiii. Destination signs;
 - xiv. Diagnostic test equipment;
 - xv. Door actuation and control equipment;
 - xvi. Driver’s cab layout;
 - xvii. Gearbox and coupling;
 - xviii. Ventilation and air conditioning equipment;
 - xix. Lighting equipment;
 - xx. PA system;
 - xxi. Power collection equipment;
 - xxii. Power conversion equipment;
 - xxiii. Power electronics control equipment;
 - xxiv. Propulsion control;
 - xxv. Radio and communications equipment interface;
 - xxvi. Seats;
 - xxvii. Traction motor;
 - xxviii. Train Management System (TMS);
 - xxix. Wheel sets; and
 - xxx. Windows and glazing.

- 22.2.3 During the Conceptual Design, the system and subsystem requirements shall be finalized.
- 22.2.4 During the Preliminary Design, all interface requirements are identified and finalized, such as envelope dimensions, weights, electrical and pneumatic requirements, and functional interactions.
- 22.2.5 During the Final Design, the hardware designs shall be finalized.

22.3 Design Approval Process

- 22.3.1 The Contractor shall follow the design submission and review process outlined in ERT Sub-Clauses 22.1 - Project Management Requirement and 22.2 - Engineering Schedule and Reviews, and submit the documentation required by Clause 19 General Documentation Requirements. Upon approval of the manufacturing drawings and documentation, the Contractor shall begin manufacturing.
- 22.3.2 The Engineer’s response to the submission shall be made within 45 days of receipt of the submission; however, the Engineer shall endeavor to respond within 30 days, provided that the submission is made no later than the date shown on the design submissions program. The Engineer may extend the review period depending on the amount of documentation accompanying the submission.

22.4 First Article Configuration Inspection

- 22.4.1 Prior to serial production taking place, the Contractor shall conduct a First Article Configuration Inspection (FACI), in accordance with a procedure to be reviewed by the Engineer, during which the first component produced shall be subjected to a rigorous test and inspection to confirm that the hardware fully complies with the Contractor’s design and manufacturing process requirements. Hardware inspections may take place prior to this point, initiated either by the Contractor or the Engineer, but they shall be considered hardware reviews, and not FACI’s.
- 22.4.2 At the FACI, the Contractor shall make available all pertinent design and manufacturing process documentation, test records, material certifications, etc. Should all the requirements of the FACI not be met, then the inspection shall be considered a hardware review.
- 22.4.3 Upon acceptance of the FACI by the Engineer, the Contractor is then free to proceed to manufacture all pertinent hardware. The hardware must meet or exceed the quality standards set at the FACI, and must incorporate any comments made by the Engineer at the FACI.
- 22.4.4 The Contractor is reminded, however, that the installation of any unproved (changed) component or equipment in the car shall likewise be subject to the FACI process.
- 22.4.5 All hardware entering into the construction of the cars shall be subject to the FACI process.
- 22.4.6 At a minimum, the following equipment shall undergo the FACI process:
 - i. On-board signaling equipment interface;
 - ii. Auxiliary Power Supply Equipment (APSE);
 - iii. Battery;
 - iv. Bogies;
 - v. Braking equipment, including air compressor;
 - vi. CCTV system;
 - vii. Car body structure;
 - viii. Air compressor;
 - ix. Car interior arrangement;
 - x. Car roof layout;
 - xi. Car underfloor layout;

- xii. Couplers;
- xiii. Destination signs;
- xiv. Diagnostic test equipment;
- xv. Door actuation and control equipment;
- xvi. Driver’s cab layout;
- xvii. Gearbox and coupling;
- xviii. Ventilation and air conditioning equipment;
- xix. Lighting equipment;
- xx. PA system;
- xxi. Power collection equipment;
- xxii. Power conversion equipment;
- xxiii. Power electronics control equipment;
- xxiv. Propulsion control;
- xxv. Radio and communications equipment interface;
- xxvi. Seats;
- xxvii. Traction motor;
- xxviii. Train management system;
- xxix. Wheel sets; and
- xxx. Windows and glazing.

22.5 Systems Integration

- 22.5.1 The Contractor shall submit a Systems Integration Plan for review.
- 22.5.2 This plan shall describe in detail the means by which the Contractor shall ensure that all systems and subsystems are compatible with each other, and shall work together to satisfy the requirements of this ERT.

22.6 Technical Support

- 22.6.1 The Contractor shall make available experienced maintenance engineers & maintenance staff to provide assistance throughout the whole Defects Notification Period (DNP). All works carried by the Contractor during the Defects Notification Period shall be carried out within the operating schedule maintenance periods.
- 22.6.2 Assigned maintenance engineers and staff shall have good command of English language.
- 22.6.3 Access to the depot and to cars by the Contractor’s staff shall be controlled by the Engineer. The Contractor shall adhere to all the Employer’s working practices, including safety procedures of the Employer.
- 22.6.4 The Contractor shall provide operation and maintenance training to the Employer, as defined in Clause 14 - Training of the ERG.
- 22.6.5 Where defects notification maintenance or additional work is required on the cars, the procedure and documentation for the work shall be strictly applied, regardless of whether the work is carried out by the Contractor and/or the Employer.
- 22.6.6 The Contractor shall provide an office space at the site, from the Commencement Date until the end of Defects Notification Period (DNP), for ten (10) engineers, and equipped with complete facilities. As a minimum, the office shall be equipped with the following essential furniture/equipment:
 - a. Tables and chairs for ten persons;
 - b. Secured locker cabinet (10 units);
 - c. Telephone line with international direct dial;

- d. Fax machine and photocopier machine (latest model heavy duty);
- e. Computer with internet connection (ten (10) sets, current model with printers and all peripherals);
- f. Air conditioning; and
- g. Meeting room with 1 conference table, 10 chairs, white board and bookshelves

22.6.7 All equipment stated above shall be handed over to the Employer after the completion of the depot.

22.6.8 **Cars for the Employer**

22.6.8.1 It shall be decided in liaison with the Contractor the best arrangement to ensure the following cars are available as a minimum up to the point of issue of the TOC.

22.6.8.2 These cars may be purchased in accordance with existing laws, rules and regulations, or leased by the Contractor, or a combination of both arrangements, whichever is best suited for the particular situation subject to the Engineer’s review.

22.6.8.3 Leased cars will go off-hire but any purchased cars shall be transferred to the Employer at this time.

22.6.8.4 For the Employer; 5 units – MPV or SUV, Diesel, automatic transmission.

22.6.8.5 Authorized drivers only shall be allowed to use the cars, which shall be well maintained to the appropriate standard.

22.7 **Warranties/Guaranties**

22.7.1 The Contractor shall warrant that the design, materials and workmanship incorporated and used in the production of each system and car shall be free from defects and that system and its related components and apparatus comply with their corresponding specifications and/or relevant Engineer reviewed data and drawings.

22.7.2 Unless otherwise specified, the guarantee period for the following components shall commence from the date of issue of the Taking Over Certificate (TOC), which shall be done after all action items have been closed out on the car on which they are installed.

22.7.2.1 The car body structure (including the underframe and support brackets) shall be guaranteed for not less than ten (10) years;

22.7.2.2 The following equipment shall be guaranteed for an extended period of five (5) years:

- a. Major components of the bogie (bogie frame, axles, suspensions, traction motors, gearboxes, etc.);
- b. Areas painted for corrosion protection; and
- c. Glass.

22.7.2.3 The car batteries shall be guaranteed for not less than three (3) years; and

22.7.2.4 All other car components and system shall be guaranteed for a period of two (2) years.

22.7.3 Responsibility of the Contractor

- 22.7.3.1 Under the Warranties/Guarantees, the Contractor shall be responsible, at their own cost and expense (including cost of removal and installation), for the repair and/or replacement of each component or apparatus which, under normal use and maintenance becomes defective or inadequate in the performance of its function during the warranty/guarantee period, or during such period fails to comply with the ERT.
- 22.7.3.2 Should the removal or replacement of a failed component or apparatus cause removal or replacement of any other equipment or parts, such work and related cost shall be borne by the Contractor.
- 22.7.3.3 The warranty/guarantee covering any component or apparatus repaired or replaced by the Contractor shall be renewed for a period equal to the period of the original warranty/guarantee effective as of the day when such repaired/replaced part was installed.
- 22.7.3.4 If the failure is found to affect any other component or apparatus, the renewal of the warranty/guarantee shall also be extended to cover the components or apparatus so affected, and shall start as of the date the interrelated components and apparatus function was restored.

22.7.4 Fleet Defects (Pattern Failures)

- 22.7.4.1 The occurrence of independent failures of the same warranted item that exceeds more than 3 percent of the total number of identical items supplied may be declared a fleet defect or pattern failure.
- 22.7.4.2 On this basis, the Contractor shall be required to develop and implement an encompassing corrective action program to eliminate the pattern failure.

22.8 Computerized Maintenance Management System

- 22.8.1 The Contractor shall support the Computerized Maintenance Management System (CMMS) development by the CP NS-01 Contractor.
- 22.8.2 The Contractor shall coordinate and agree with the CP NS-01 Contractor and provide the necessary required data for the MMS.

23 Quality Assurance Requirements

23.1 General

- 23.1.1 The Contractor shall submit a Quality Management Plan for the Engineer’s review and acceptance as required in Sub-Clause 1.7.1 of the General Requirements. The plan shall delineate the responsibilities of the Quality Assurance organization in the Contractor's company, including personnel reporting arrangements.
- 23.1.2 This plan shall describe the Contractor’s quality assurance organization, including the names of personnel to be assigned to the Project, and shall describe the responsibilities of each separate unit and their contribution to the Project. In particular, the plan shall describe the quality organization's involvement and influence at all stages of the Project.
- 23.1.3 In the plan, the Contractor shall describe the means by which the Contractor shall utilize the quality assurance organization to adequately control all in-house work, and that of major suppliers and sub-suppliers, including ensuring their adherence to the requirements of this ERT.
- 23.1.4 The Contractor's Quality Management Plan shall also describe the procedure to be used to ensure that the First Article Configuration Inspection (FACI) process is controlled, and that series production does not take place until the product has been accepted by the Engineer. Also to be included is a thorough description of the means used to control engineering changes and field changes.

23.2 Configuration Control

- 23.2.1 In order to control the car configuration, the following requirements shall be adhered to for all changes to all equipment following First Article Configuration Inspection (FACI).

23.2.2 Design Changes

- 23.2.2.1 The Contractor shall submit design details of the change proposed to the Engineer for review and determination. In some cases, at the discretion of the Engineer, a simple verbal explanation shall be sufficient for preliminary review and acceptance. In all cases however, a written explanation shall be required for final acceptance.
- 23.2.2.2 The written explanation shall take the form of a Field Modification Instruction (FMI) or service bulletin, together with updated engineering drawings.
- 23.2.2.3 Before any modifications are made to cars, the FMI and design details must be reviewed and accepted by the Engineer.
- 23.2.2.4 The format and content of the design change notice is the responsibility of the Contractor to determine, based on the Contractor's normal method of operation.
- 23.2.2.5 Only with the express approval of the Engineer shall the above procedure be waived.
- 23.2.2.6 The Contractor shall submit to the Employer for review a monthly listing of all active design change requests and their implementation status.
- 23.2.2.7 As a minimum, the design change request shall contain the following information:
- a. Description of subject;
 - b. Reason for change;
 - c. List of related documents;
 - d. The supplier & manufacturer part numbers, serial numbers, quantities and location of affected parts or assemblies;
 - e. The parts required to make the change;

- f. The effect of the change on interchangeability;
- g. Special tool requirements;
- h. Material disposition (rework, scrap, etc.);
- i. A detailed procedure for making the change;
- j. Test equipment required; and
- k. Test procedure.

23.3 Part Numbers and Serial Numbers

- 23.3.1 The Contractor shall permanently identify all hardware components to the lowest level of repair and replacement. The hardware identification marking shall at all times coincide with the officially released engineering data.
- 23.3.2 Major assemblies and subassemblies shall be assigned individual serial numbers. Duplicate serial numbers shall not be used within a type or model series. The serial number shall be marked on the equipment nameplate.

24 Spare Parts and Special Tools

24.1 General

- 24.1.1 The Contractor shall provide spare parts, special tools as specified in both the General Requirement as well as this Clause.
- 24.1.2 Prior to the issuance of the Taking Over Certificate (TOC), the Contractor shall deliver the spares and consumables, special tools and diagnose test equipment to the Site.

24.2 Spare Parts

- 24.2.1 The Contractor shall provide a list of capital spares and consumables (spares and consumables) and supply for the Defects Notification Period (DNP).
- 24.2.2 The Employer may order additional spares required for the following 15 years from the recommended spare parts and consumables list as provided by the Contractor.
- 24.2.3 The Contractor shall provide a complete listing of spares and consumables to be supplied, including the following information:
- a. Contractor part number;
 - b. Original equipment manufacturer part number; and
 - c. Part description.
 - d. Price
 - e. Primary Vendor name/contact/address
 - f. Secondary Vendor name/ contact/ address
- 24.2.4 The contractor shall submit the final list of capital spare during the design stage.

24.3 Spares Parts and Consumables Required During the Defects Notification Period

- 24.3.1 The Contractor shall supply the spares and consumables to service the trains during the DNP.
- 24.3.2 In case any of these spares and consumables are used during the DNP, they shall be replenished immediately at no extra cost to the Employer.
- 24.3.3 Immediately after the DNP, the Contractor shall handover to the Employer additional spares and consumables required, if any, to complete the total of these items, as per the list.
- 24.3.4 If any additional spares and consumables including parts replacement, which has not being listed, become necessary during the DNP, the same shall be added to the list and shall be provided by the Contractor, along with one additional set for any further requirement at no additional cost. The cost for the same shall be deemed to have been included in the Price Schedules.

24.4 Spares Parts and Consumables Required After the Defects Notification Period

- 24.4.1 The Contractor shall submit a list of recommended spare parts and consumables deemed to be required in the course of normal train operation after the DNP.
- 24.4.2 The list shall quote the unit rates with guaranteed prices valid up to one year after the completion of the DNP, but after this, all price escalation shall be considered but the Contractor shall give an escalation formula to be applied to the quoted price, in case spares are ordered later than one year after the completion of the DNP.
- 24.4.3 The recommended spare parts list shall be reviewed and finalized based on the experience of operation of the train service in the first year of DNP.

24.5 Guaranteed Period of Spare Parts

- 24.5.1 The Contractor shall provide an Obsolescence Plan covering the availability of Spares and Consumables for a period of not less than 15 years from the date of completion of the DNP.
- 24.5.2 Should the manufacturing of the listed parts, spares and consumables be discontinued due to unavoidable circumstances, before the end of the 15 years covered by the Obsolescence Plan, the Contractor shall give sufficient notice to the Employer of such intention. The Employer shall be given sufficient opportunity of ordering such quantities of spare parts the Employer may require prior to close-down of production.
- 24.5.3 Should circumstances beyond the Contractor’s control prohibit the Contractor complying with the above obligations, the Employer shall by default be entitled to the following, but not limited to:
 - a. Manufacturing drawings;
 - b. Specifications;
 - c. Patterns; and
 - d. All other relevant information in respect of each spares item affected.
- 24.5.4 This is to enable the Employer to make or have made such spare parts.
- 24.5.5 Under the aforesaid circumstances, the Contractor shall also grant to the Employer, without payment of any royalty or charge, full right and liberty to make and have made such spare parts and make copies of such drawings, patterns, specifications and other information, provided it is for exclusive use of the Employer and only for the Project covered under this Contract.

24.6 Special Tools

- 24.6.1 The Contractor shall provide a sufficient number of special tools required, to enable the Employer to properly maintain the trains.
- 24.6.2 These tools shall include, but not be limited to special assembly/disassembly jigs, test benches, simulators (as applicable) handling tools, equipment mounting/dismounting tools, diagnostic test equipment for all electronic assemblies, test stands and simulators as may apply, interface hardware & software, hook-up lines/cables to test all train line systems, and other tools considered particular to the car and its equipment.
- 24.6.3 The number of tools required to be supplied shall be as reviewed by the Engineer.

24.7 Diagnostic Test Equipment

- 24.7.1 The Contractor shall provide diagnostic test equipment to ascertain the functionality of all discrete pieces of specialized equipment. This equipment shall consist of embedded fault monitoring and diagnostic systems, portable test equipment and shop test equipment.
- 24.7.2 The portable test equipment shall consist of a suitable number of pre-programmed laptop computers and standard cable connectors, as reviewed by the Engineer. The Portable Test Units (PTU) shall be connectable to the equipment to be tested, allowing faults to be quickly and easily diagnosed and allow data download and analysis.
- 24.7.3 Connection points shall be provided both on the inside and exterior of the cars, as required, in order to be able to quickly diagnose faults with associated systems. The location of these points shall be reviewed by the Engineer.
- 24.7.4 Portable test equipment shall be provided for each major car system including all interface software and hardware. Test capability shall include, but not limited to, measurement of major car parameters, such as line current, line voltage, traction current, tractive effort, speed and others, both in static and dynamic conditions.
- 24.7.5 The shop test equipment shall consist of at least one set of test benches for each major car system, or simulator, as may be applicable, whereby the equipment to be tested is removed from the car and loaded onto the test bench. The test equipment shall allow all faults to be easily and quickly diagnosed. Each test unit shall be completely wired and shall use 220 V ac, 60 Hz single phase power and compressed air, as may be needed.
- 24.7.6 The Contractor shall provide sufficient number of items of this test equipment to allow the Employer to properly maintain and repair the trains. The number of test equipment items shall be reviewed by the Engineer, based on an operational analysis to be performed by the Contractor.
- 24.7.7 The Contractor shall be required to maintain the equipment software throughout the DNP and handover the same at the end of the DNP. As part of the diagnostic test equipment, the Contractor shall provide the following:
- a. Complete operational manual, schematic diagrams, maintenance and calibration instructions for the equipment, including printed circuit boards and microprocessors;
 - b. Complete schematic diagrams and maintenance and calibration instructions for the car-borne system and its printed circuit boards directly associated with the diagnostic test equipment;
 - c. Spare parts and consumables;
 - d. Five (5) sets of replacement cable and connector assemblies and a suitable amount of interface hardware for each piece of test equipment;
 - e. Any other parts/item necessary or required to complete the diagnostic tests; and
 - f. An external re-loadable software (in CD or USB) as back-up installer shall be made available in case the PTU/laptop software for diagnostics become corrupted.
- 24.7.8 There shall be no restriction (license) in the usage of the re-loadable software.

24.8 Main Special Tools and Diagnostic Test Equipment

24.8.1 The main Special Tools and Diagnostic Test Equipment is listed, but not limited, as follows:

Table 24.1 Main Special Tools and Diagnostic Test Equipment

ID	Name
Light repair (2 depots)	Safety device tester
	Event recorder reader
	VVVF log reader
	Brake control unit log reader
	Rewriting device for internal display system
	Rewriting device for external display system
	Rewriting device for public address system
	Brake-pad replacement tool
PTU	VVVF
	BCU
	ACU
	Doors
	TMS
	APSE
Bogie removal	Radius arm gauge
Traction Motor	Motor disassembling/reassembling tools
	WM coupling extractor
	Non-disassembling bearing exchange special tool
Bogie	Bogie disassembling/reassembling special tools
	Lock bolt for axle spring
Tight lock coupler and draft gear	Special tool for draft gear
Air Conditioner	Special tool for air conditioner overhaul
	Refrigerant extractor
	Refrigerant filler
	Gas leak tester
	Cleaner for special parts
Electric Shop	HB tester
	High voltage device tester
	Contacto tester

ID	Name
	Solenoid valve tester
	Electronic relay tester
	Door operating device tester
	Safety device tester
	Event recorder reader and analyzer
	Failure data reading device
	Train radio tester
	Speed sensor tester
	VVVF inverter tester
	VVVF log reader
	Cleaner for special parts
Bearings	Special tool for bearing overhaul
Spring, Air Spring & Iron work	Special tool for air-spring overhaul
	Special tool for damper overhaul
Air Brake valve	Brake test equipment
	Brake control unit log reader
	Special tool for air valve overhaul
	Special tool for compressor overhaul
Final adjustment	Safety device tester
	Event recorder reader

- 24.8.2 The final special tools and diagnostic test equipment list shall be determined after the Operation and Maintenance (O&M) Manuals have been concluded.
- 24.8.3 If any additional special tools and diagnostic test equipment are identified during the development of the (O&M) Manuals, those items shall be added to the list proposed during the Bid and shall be provided by the Contractor. The cost for the additional special tools and diagnostic test equipment shall be deemed to have been included in the Price Schedules.

25 Supply of Equipment for Training Center

25.1 Equipment for Driving Simulator

25.1.1 The Contractor shall prepare the equipment for driving simulator as below, and supply to the Driving Simulator Contractor.

Description	Qty.	Remarks
Cab saloon partition door	1 set	
Cab seat	1 set	
Cab side doors	1 set	
Coupler items	1 set	Automatic coupler, Valve, Jumper cable and Flag are included.
Door	1 set	Emergency switch and unlock system are included.
Passenger side door system	1 set	Passenger door manual release mechanism (inside and outside) is included.
Passenger emergency call system	1 set	
Brake release valve	1 set	
Driver’s Console	1 set	Master Controller, Buttons switch panels, Gauges, Electric meters, TMS unit, Signal monitor ^(*) , Wiper, Sun-visor are included.
Handy talks except for Digital Space Radio ^(*) (PA, PEC, and Driver/Trainee)	1 set	Connect to Instructor’s Console.
Train Protection Radio	1 set	
Sound system	1 set	Simulated PA systems and train radio system, Speaker (inside and outside) are included.

(*1): Signaling equipment is supplied by E&M signaling Contractor (CP NS-01).

(*2): Digital Space Radio is supplied by E&M Signaling Contractor (CP NS-01).

25.1.2 Regarding the detail of the way to supply to the Driving Simulator Contractor, the amount of spare parts and so on, the Contractor shall adjust with the CP NS-01 Contractor.

25.2 Pantograph and Bogie Assembly

- 25.2.1 The Contractor shall prepare and supply the equipment for Training Center as below:
- a. Pantograph and Bogie Assembly: 1 set
 - b. Bogie-assembly for Motor-car including traction motor, gearbox, and coupling: 1 set
- 25.2.2 Regarding the detail of the way to supply, the Contractor shall adjust with the CP NS-01 Contractor.

26 Asset Register

26.1 General

- 26.1.1 The Contractor shall provide information and data to populate the CMMS Database Server which shall include but not be limited to:
- a. Asset Register
 - b. Maintenance Schedule
 - c. Administrative Schedule
- 26.1.2 The Contractor shall provide the “equipment/asset taxonomy” for populating the CMMS Database server. The asset taxonomy shall comprise, but not limited to:
- a. Industry;
 - b. Location (i.e depot location);
 - c. Department (i.e RSM/ Engineering/ etc);
 - d. Section (i.e Light, Heavy maintenance/ etc)
 - e. Systems;
 - f. Sub-systems;
 - g. Equipment number;
 - h. Equipment description;
 - i. Manufacturer name;
 - j. Manufacturer address;
 - k. Supplier name;
 - l. Supplier contact name and address;
 - m. Equipment criticality;
 - n. Equipment types/ class;
 - o. Operating status;
 - p. Name plates or specifications;
 - q. Start of Warranty date;
 - r. End of Warranty date;
 - s. Safety Precautions
- 26.1.3 The Contractor shall provide the following information for the consumable parts or materials for the CMMS system, but not limited to:
- a. Part number;
 - b. Description;
 - c. Specification;
 - d. Inventory Type;
 - e. Inventory Class;
 - f. Unit measure;
 - g. Price;
 - h. Primary Vendor name/ contact/ address

- i. Secondary Vendor name/ contact. Address
 - j. Order to delivery turnaround time.
- 26.1.4 The Contractor shall provide a System Maintenance Schedule for populating the CMMS Database Server for rolling stock.
- 26.1.5 The Contractor shall provide an Administrative Schedule to the CMMS Contractor to populate the CMMS Database Server which shall include but not be limited to:
- a. Personnel Details;
 - b. Training;
 - c. Warranties;
 - d. Work schedule;
 - e. Job Cards

27 Shipping and Delivery

27.1 Shipping

- 27.1.1 At no time shall cars or other parts be exposed to salt water or spray when unprotected, loading on deck shall not be allowed.
- 27.1.2 The Contractor shall prepare a shipping manual to cover the shipping of all items covered under the Contract, including cars, spare parts and simulator. The shipping manual shall detail the method, packaging and other details required to ensure the safe shipment to the delivery point. The shipping manual shall be submitted for review by the Engineer prior to the shipment of any equipment.
- 27.1.3 The Contractor shall notify the Engineer ten days in advance of any expected shipment date and give further notification of the actual shipment date and routing when established. This shall complement the inspection requirements prior to delivery as specified herein.
- 27.1.4 Unless otherwise reviewed by the Engineer, no loose or boxed equipment shall be permitted to be shipped in the cars.
- 27.1.5 The Contractor shall be responsible for the insurance for shipping.

27.2 Delivery

- 27.2.1 The Contractor shall be responsible for delivery of all items to be supplied under this Contract to the Site, as designated by the Engineer.
- 27.2.2 The Contractor shall be responsible for the loading, transport and unloading of cars and spare parts from the factory site to the designated delivery point and locating them as instructed by the Engineer.
- 27.2.3 Cars, parts or items damaged in transit shall not be considered as delivered until all repairs or replacements have been completed and all necessary spare parts or items have been delivered to the Site.
- 27.2.4 All documents, manuals, drawings and other deliverables shall be delivered to MCRP&NSRP-South operator, Philippines.
- 27.2.5 The Contractor shall be responsible for all storage and security of cars, spare parts and other items until the items have been inspected and are considered delivered at the point designated by the Engineer.
- 27.2.6 Removal of all temporary fittings required for shipment and re-assembly of equipment shall be the responsibility of the Contractor, and shall be completed prior to the car parts being inspected and considered delivered.
- 27.2.7 Prior to delivery, the Contractor is recommended to plan the route to ensure they are aware of actual road conditions, underpasses, bridges and potentially other construction work which may hinder his delivery from port to the Site.
- 27.2.8 The Contractor shall comply with the requirements of the Employer or any relevant section of local government and/or any other relevant authority regarding any traffic arrangements that may be necessary for delivery of the car plus other equipment from port to the Site. The Contractor shall make all arrangements and assume full responsibility for transportation to the Site.

APPENDIX TO TECHNICAL REQUIREMENTS

Table of contents

Appendix. A	Schematic Diagram of Basic Vehicle Configuration (for reference)
Appendix. B	Rolling Stock and Structure Gauges
Appendix. C	Schematic diagram of Vehicle (for reference)
Appendix. D	Door Positions in The Car and Door Pitches
Appendix. E	Tractive Effort Curve and Regenerative Effort Curve
Appendix. F	Schematic diagram of model of control transmission system (for reference)
Appendix. G	Schematic diagram of model of monitor transmission system (for reference)
Appendix. H	Sample data of run-curve simulation for considering the capacity of Propulsion system (Station data for NSCR, MCRP and NSRP-South)
Appendix. I	Sample data of run-curve simulation for considering the capacity of Propulsion system (Speed Limit of NSCR, MCRP and NSRP-South)
Appendix. J	Sample data of run-curve simulation for considering the capacity of Propulsion system (Gradient for NSCR, MCRP and NSRP-South)
Appendix. K	Sample data of run-curve simulation for considering the capacity of Propulsion system (Curvature NSCR, MCRP and NSRP-South)
Appendix. L	Schematic Diagram of Rolling Stock Gauge and Construction Gauge

Appendix. A Schematic diagram of basic vehicle configuration (for reference)

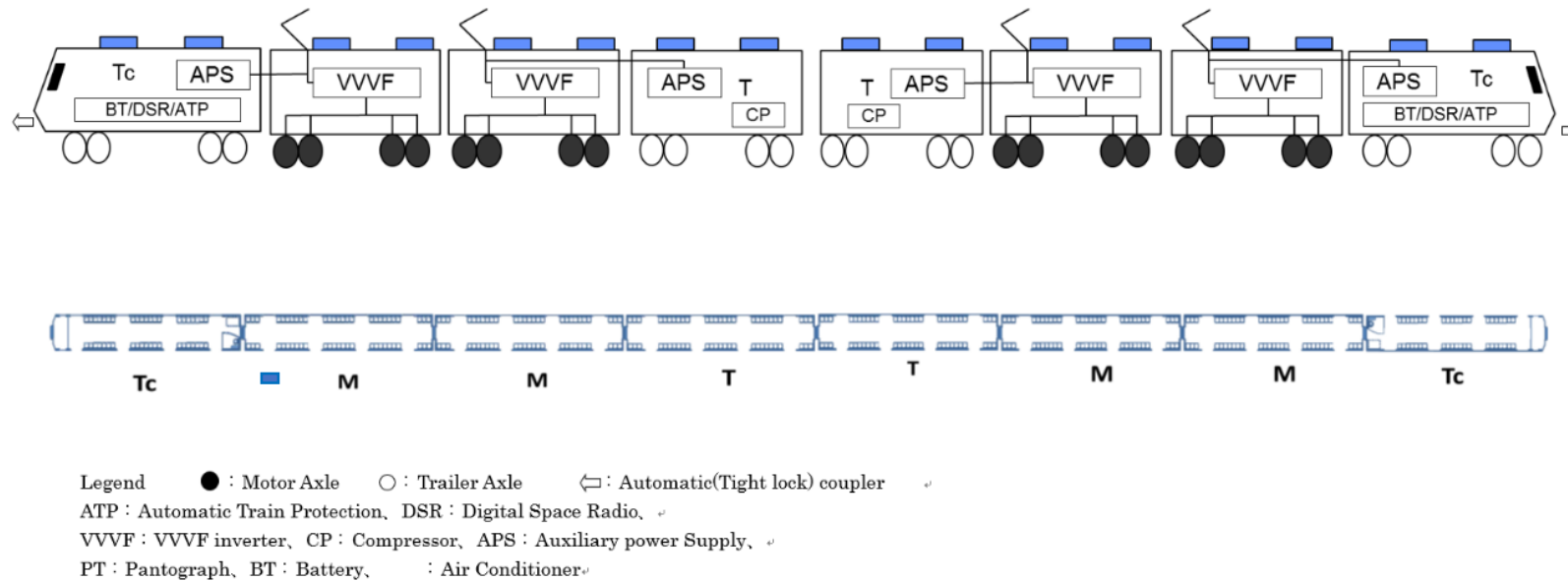

Appendix. B Rolling Stock and Structure Gauges

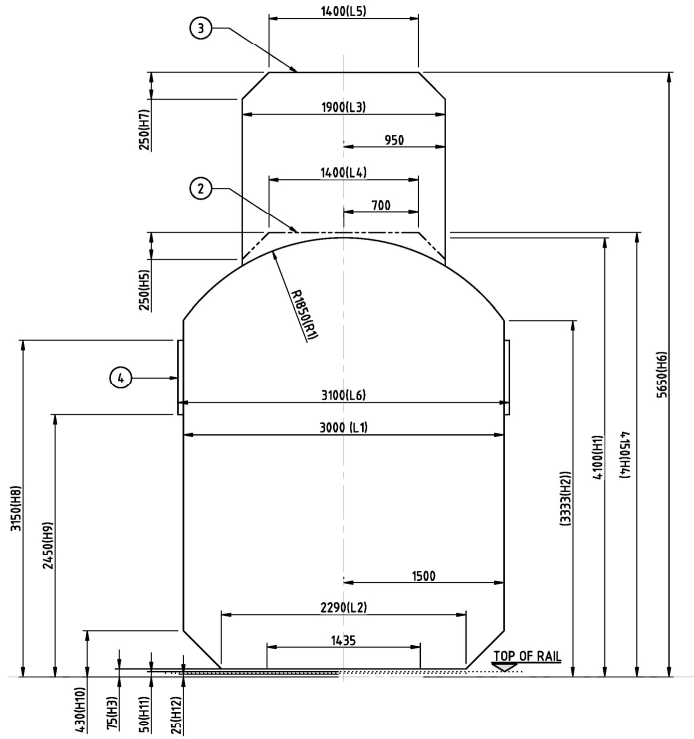

ROLLING STOCK GAUGE
SCALE 1:25

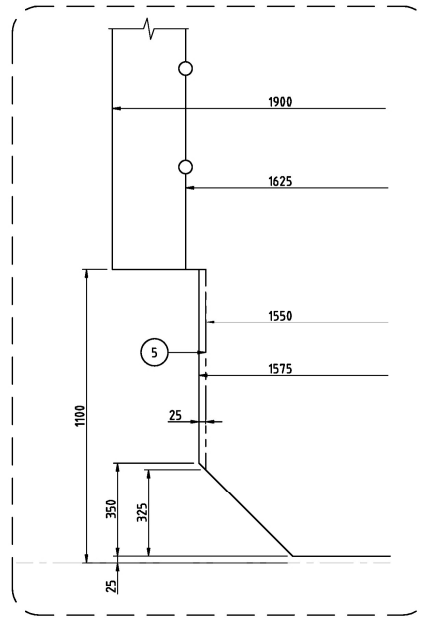

DETAIL
SCALE 1:10

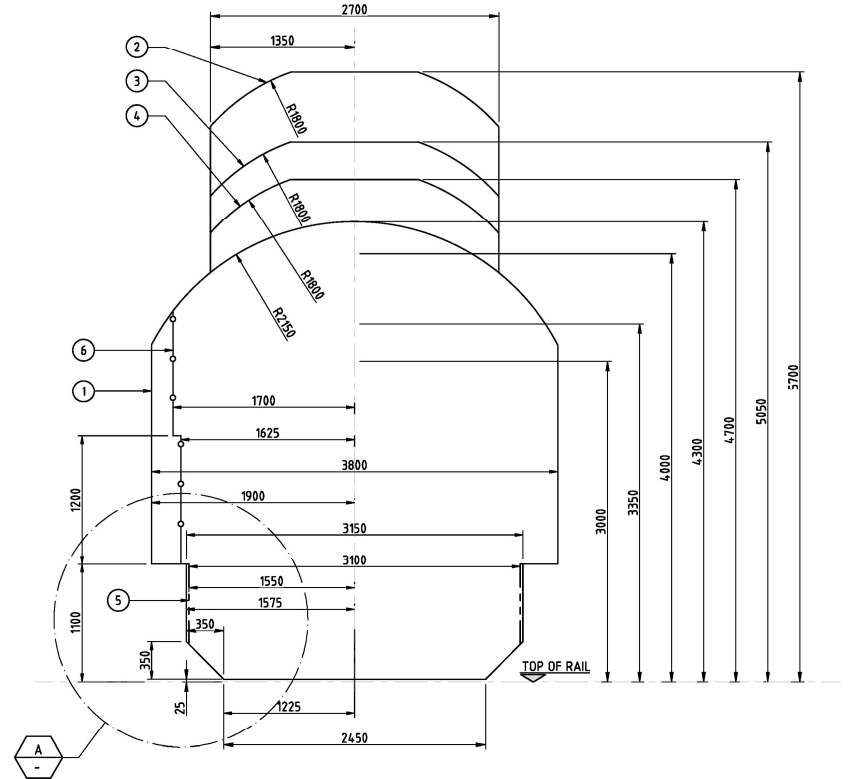

CONSTRUCTION GAUGE EXCEPT STATION PLATFORM SECTION
SCALE 1:25

①	ROLLING STOCK GAUGE	H1,H2,H3,H10,L1,L2,R1
②	GAUGE FOR EQUIPMENT ON ROOF WITH FOLDING PANTOGRAPH	H4,H5,L3,L4
③	GAUGE FOR EQUIPMENT ON ROOF WITH UNFOLDING PANTOGRAPH	H6,H7,L3,L5
④	GAUGE IN RELATION TO SIGNS, MARKER LAMPS, CAR SIDE LAMPS.	H8,H9,L6
	GAUGE IN RELATION TO PARTS THAT DO NOT MOVE VERTICALLY DUE TO ACTION OF BOGIE SPRING.	H11,L2
	GAUGE IN RELATION TO SANDING PIPE, OBSTACLE DEFLECTOR, BRAKE SHOE AND OTHER PARTS THAT DO NOT EXCEED THE WHEEL RIM WIDTH.	H12

①	BASIC GAUGE
②	GAUGE FOR TRUCK ON WHICH TRAINS RUN RECEIVING SUPPLY DIRECT CURRENT
③	GAUGE FOR TUNNEL, BRIDGES, OVERPASS, ALONG TRACK ON WHICH TRAINS RUN RECEIVING SUPPLY OF DIRECT CURRENT.
④	GAUGE FOR TUNNEL SECTION IN CASE OF USING RIGID OVERHEAD WIRE OR SAFE SUPPORTING SYSTEM.
⑤	GAUGE ONLY PLATFORM EDGE. REMARK: IT CAN BE APPLIED WHEN THE PASSAGE VELOCITY OF A TRAIN IS 120km/h OR LESS. THE USE IN CASE OF 120km/h OR MORE IS FORBIDDEN STRICTLY. THE DISTANCE FROM PLATFORM EDGE TO ROLLING STOCK SHALL BE MORE THAN 50mm WHEN THE TRAIN SPEED IS 120km/h OR LESS. IT SHALL BE MORE THAN 60mm WHEN THE TRAIN SPEED IS GREATER THAN 120km/h.
⑥	GAUGE ONLY PLATFORM SCREEN DOOR. REMARK: IT CAN BE APPLIED WHEN THE PASSAGE VELOCITY OF A TRAIN IS 120km/h OR LESS. THE USE IN THE CASE OF 120km/h OR MORE IS FORBIDDEN STRICTLY.

NOTE:
1. ALL DIMENSIONS ARE IN MILLIMETERS UNLESS OTHERWISE MENTIONED.

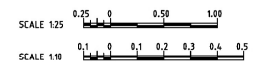

VERSIONS	DATE	DESCRIPTION
05	17 MAY 2019	NO REVISION / RE-ISSUE FOR ADDENDUM 4
06	13 FEB 2020	REVISED TO STANDARDIZE THE REVISION FOR ALL PACKAGES

DEPARTMENT OF TRANSPORTATION (DOT)
 PHILIPPINE NATIONAL RAILWAYS

CONSULTANT
 JICA DESIGN TEAM (JDT)

 ORIENTAL CONSULTANTS GLOBAL CO., LTD.
 KATAHIRA & ENGINEERS INTERNATIONAL
 PACIFIC CONSULTANTS CO., LTD.
 JAPAN INTERNATIONAL CONSULTANTS FOR TRANSPORTATION CO., LTD.
 TONICHI ENGINEERING CONSULTANTS INC.
 TOKYO METRO CO., LTD.

TITLE	JDT	SMEC
DESIGNER	S. HASHIMOTO	R. ACOSTA JR.
CHECK	S. YOSHIMOTO	V. BALAKRISHNAN
TEAM LEADER	K. KUSANAGI	W. FRENCKEN
P. MANAGER	Y. MAEDA	R. YUZON JR.

NORTH SOUTH COMMUTER RAILWAY
ROLLING STOCK AND STRUCTURE GAUGE

DATE	MAY 2019
SCALE	AS SHOWN IN A1
SHEET No.	
DRG No.	MCRP-DWG-GEN-TK-0020
DRG S.	REV 06

Appendix. C Schematic diagram of Vehicle (for reference)

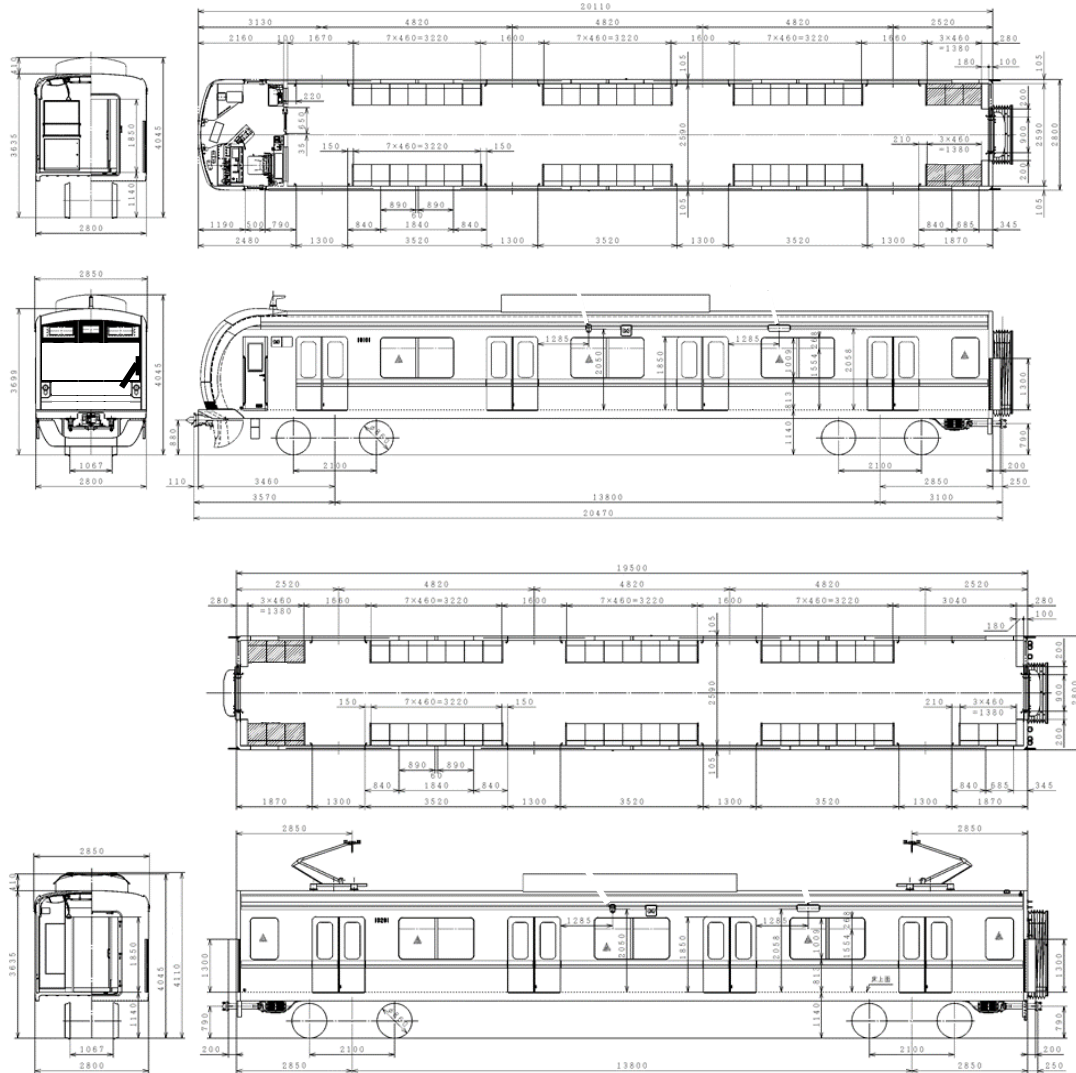

Appendix. D Door Positions in The Car and Door Pitches

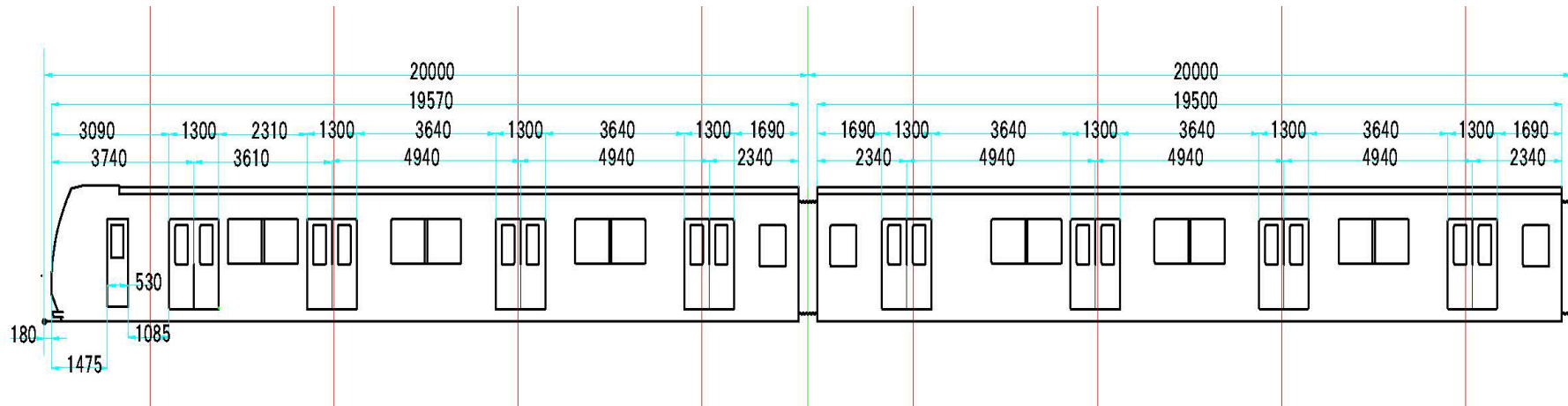

Appendix. E Tractive Effort Curve and Regenerative Effort Curve

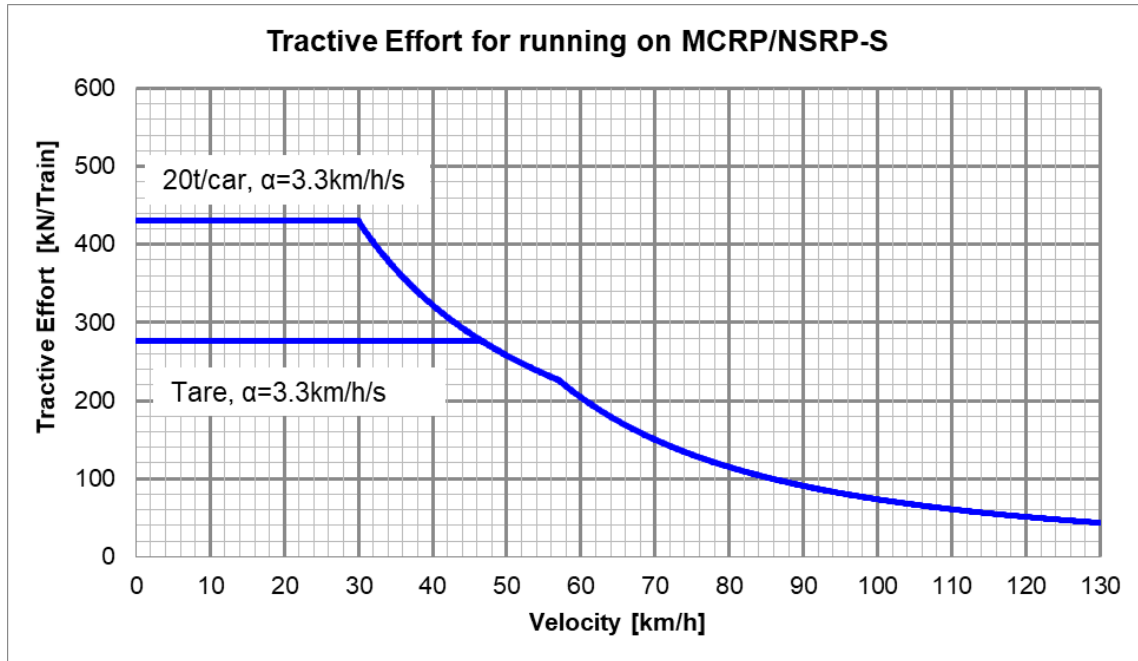

Fig.1 Tractive Effort for running on MCRP/NSRP-South at 820mm, 1350V (for reference)

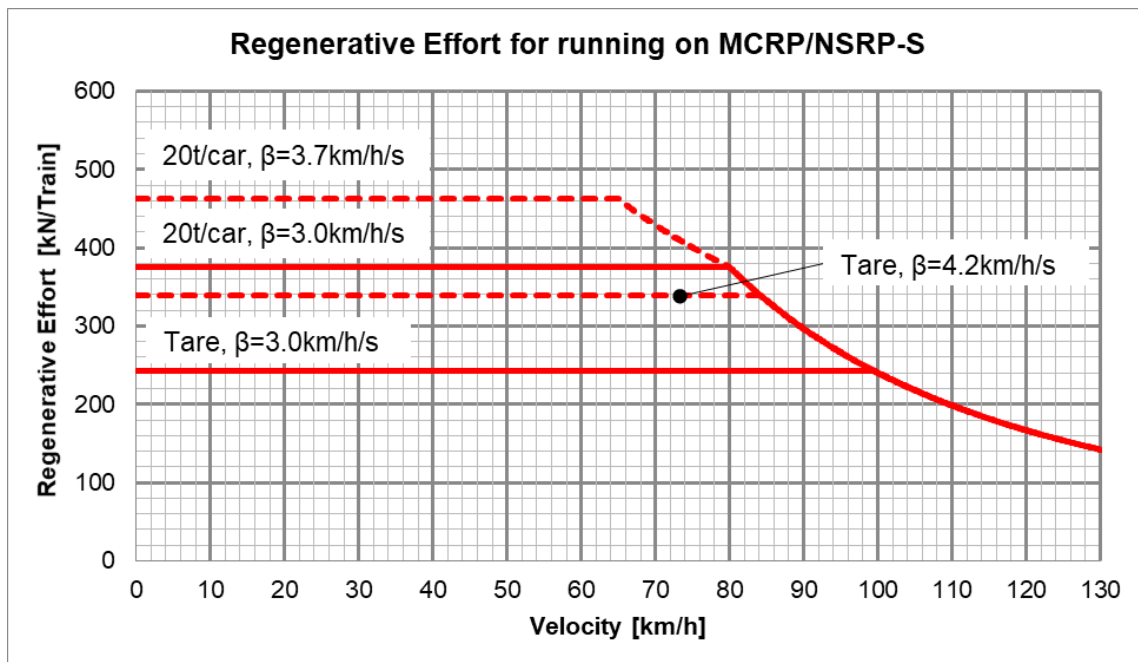
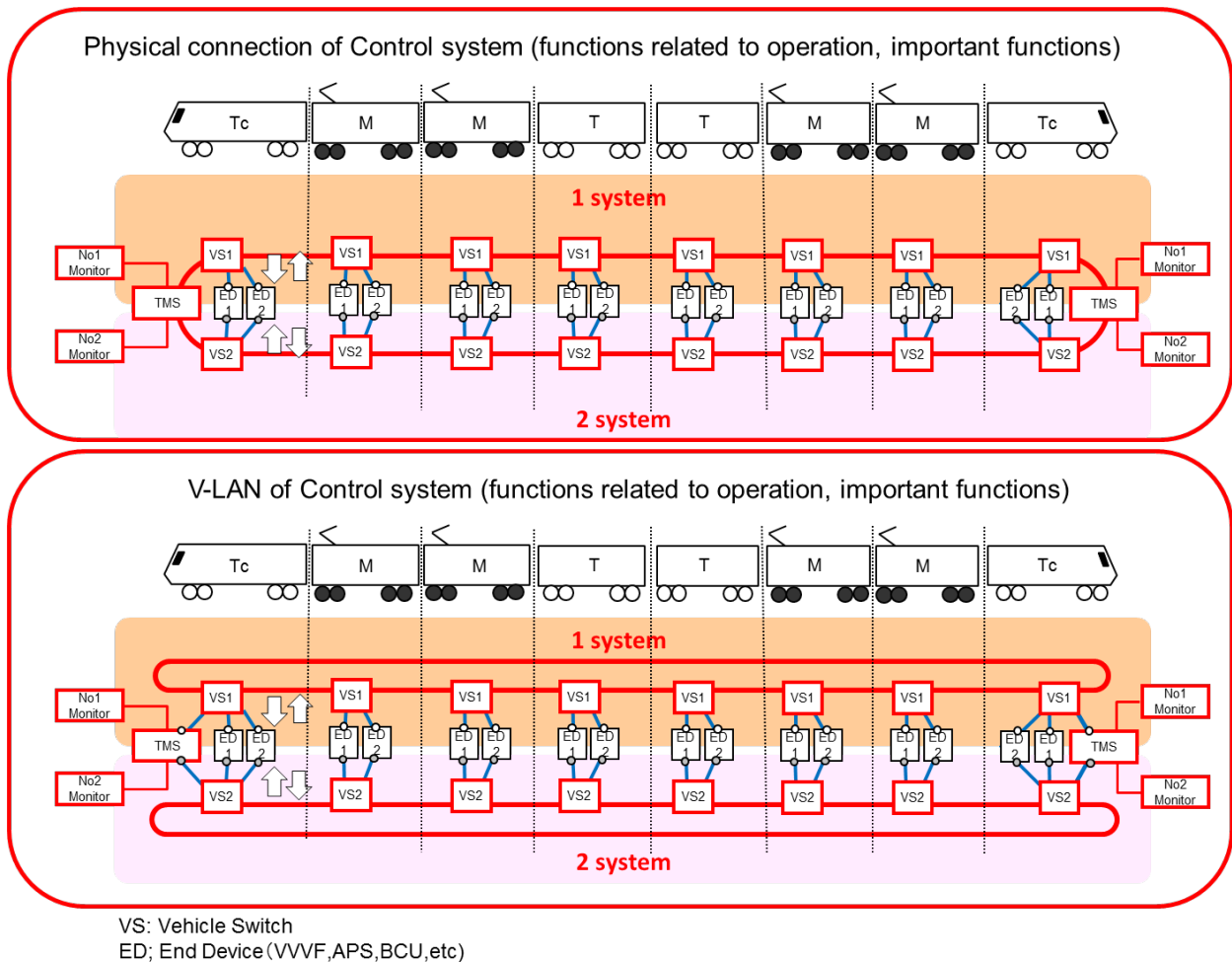
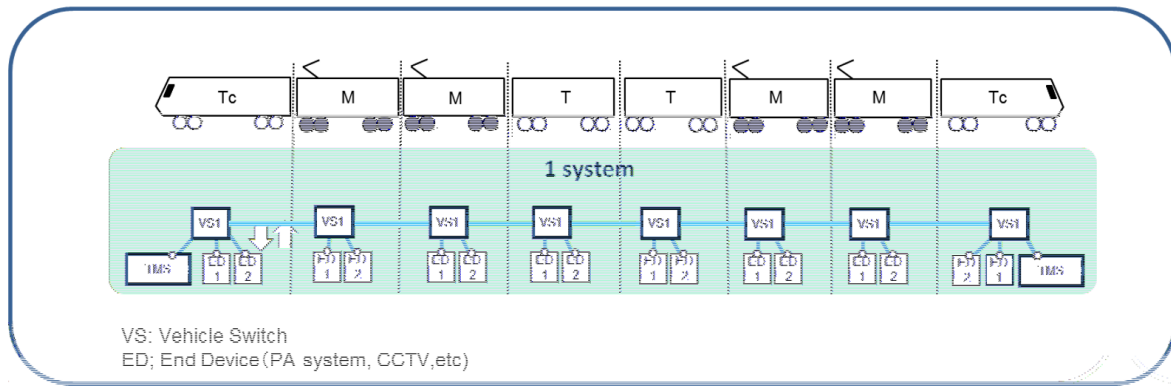

Fig.2 Regenerative Effort for running on MCRP/NSRP-South at 820mm, 1650V (for reference)

Appendix. F Schematic diagram of model of control transmission system (for reference)



Appendix. G Schematic diagram of model of monitor transmission system (for reference)



Appendix. H Sample data of run-curve simulation for considering the capacity of Propulsion system (NSCR, MCRP and NSRP-South)

Forward				Return			
Line	Station	Distance [m]	Stop time [sec]	Line	Station	Distance [m]	Stop time [sec]
NSRP-S	Calamba	0	*	MCRP	CIA	0	*
	Banlic	3321	30.0		Clark	7448	30.0
	Cabuyao	8725	30.0		Angeles	12399	30.0
	Santa Rosa	14788	30.0		San Fernando	27439	30.0
	Binan	17840	30.0		Apalit	39594	30.0
	Pacita	20403	30.0		Calumpit	44990	30.0
	San Pedro	21477	30.0	NSCR	Malolos	51892	30.0
	Muntinlupa	25383	30.0		Malolos south	55331	30.0
	Alabang	28298	30.0		Guiguinto	58177	30.0
	Sucacat	31989	30.0		Tuktukan	60526	30.0
	Bicutan	36478	30.0		Balagtas	62826	30.0
	FTI	38172	30.0		Bocause	66791	30.0
	Nichols	41530	30.0		Tabingllog	69681	30.0
	EDSA	42755	30.0		Marilao	72263	30.0
	Buendia	44693	30.0		Meycauayan	74031	30.0
	Paco	48106	30.0		Valenzuela	76849	30.0
	Santa Mesa	50881	30.0		Valenzuela Polo	79241	30.0
	Espana	53052	30.0		Malabon	82366	30.0
	Blumentritt	54627	30.0		Caloocan	83903	30.0
	NSCR	Solis St	56837		30.0	Solis	86029
Caloocan		58963	30.0	NSRP-S	Blumentritt	88239	30.0
Malabon		60500	30.0		Espana	89814	30.0
Valenzuela Polo		63625	30.0		Santa Mesa	91985	30.0
Valenzuela		66017	30.0		Paco	94760	30.0
Meycauayan		68835	30.0		Buendia	98173	30.0
Marilao		70603	30.0		EDSA	100111	30.0
Tabingllog		73185	30.0		Nichols	101336	30.0
Bocause		76075	30.0		FTI	104694	30.0
Balagtas		80040	30.0		Bicutan	106388	30.0
Tuktukan		82340	30.0		Sucacat	110877	30.0
Guiguinto		84689	30.0		Alabang	114568	30.0
Malolos south		87535	30.0		Muntinlupa	117483	30.0
Malolos		90974	30.0		San Pedro	121389	30.0
MCRP	Calumpit	97876	30.0		Pacita	122463	30.0
	Apalit	103272	30.0	Binan	125026	30.0	
	San Fernando	115427	30.0	Santa Rosa	128078	30.0	
	Angeles	130467	30.0	Cabuyao	134141	30.0	
	Clark	135418	30.0	Banlic	139545	30.0	
	CIA	142866	*	Calamba	142866	*	

(*) The dwell time is 180 sec

Appendix. I Sample data of run-curve simulation for considering the capacity of Propulsion system (Speed Limit for NSCR , MCRP and NSRP-South)

Forward			Return		
Start Dist. [m]	End Dist. [m]	Speed Limit [km/h]	Start Dist. [m]	End Dist. [m]	Speed Limit [km/h]
135.8	315.3	55	457.6	504.8	80
505.1	591.5	75	530.3	577.4	80
612.1	853.1	75	1499.8	3200.8	80
891.7	1083.7	110	3910.9	4292.0	120
2181.1	2244.8	120	4371.2	4720.0	120
2366.6	2514.5	120	4972.7	5434.0	115
2547.9	2682.9	120	5434.0	5894.0	110
2848.8	2979.1	100	6219.6	6522.9	70
3009.6	3206.4	100	6611.8	6855.4	70
3448.1	3571.7	120	7435.8	7660.6	120
3593.6	3724.6	120	8031.4	8134.0	120
3757.0	3919.9	115	8134.0	9927.8	115
3959.8	4115.0	120	10182.0	10314.4	160
4558.1	4639.4	120	10448.9	10589.9	160
5241.1	5322.4	120	10705.8	10934.0	160
6377.2	6480.8	120	10965.3	11829.0	115
6557.2	6713.1	120	11829.0	11982.1	115
6861.9	6972.3	120	12614.0	12876.5	115
7226.2	7287.0	120	13334.0	14819.0	115
7287.0	8080.2	120	16084.0	16444.0	115
8181.4	8342.6	120	19394.0	19994.0	115
8455.5	8614.9	120	21388.8	21506.5	160
8835.0	8998.8	120	21595.1	21712.9	160
9109.3	9270.7	120	22993.5	23370.4	160
9457.5	9719.0	115	23866.0	24259.0	160
11823.2	11905.6	120	25194.0	25664.0	115
11927.9	12312.0	100	25762.8	26048.6	160
12332.2	12430.4	120	26264.0	26827.0	110
14327.6	14391.3	120	28272.1	28539.1	160
14417.0	14506.1	120	28768.8	28912.4	160
14595.0	14660.0	120	29092.6	29209.9	160
15065.9	15127.9	120	29330.6	29506.7	160
15150.7	15215.1	120	29888.9	30047.6	160
15265.9	15502.0	115	30244.3	30339.3	160
15669.3	15735.2	120	30662.8	30827.2	160
16095.2	16177.9	120	31062.1	31179.4	160
16582.5	16646.1	120	31299.2	31416.5	160
17992.0	18304.0	115	31553.2	33266.9	160
19953.9	20036.3	100	35222.5	36971.0	160
20067.6	20281.4	80	38067.8	38200.1	160

Forward			Return		
Start Dist. [m]	End Dist. [m]	Speed Limit [km/h]	Start Dist. [m]	End Dist. [m]	Speed Limit [km/h]
20512.6	20585.6	100	38481.1	39272.3	160
20609.0	20682.2	100	39985.8	40135.6	160
21026.6	21145.4	120	40667.9	40865.2	160
21247.9	21366.9	120	41034.0	41534.0	115
21587.1	21712.4	120	41663.4	42442.3	120
21803.8	21942.3	120	43000.2	43206.4	160
22295.8	22397.0	120	43274.0	43840.3	115
22428.1	22516.0	120	43898.5	44599.4	110
22562.0	23146.0	110	45016.4	45154.5	160
23586.5	24029.4	105	45456.8	45685.3	160
24152.0	24352.0	115	45958.5	46090.8	160
24552.7	24616.4	120	47065.2	47194.2	160
25052.9	25116.6	120	47340.5	47559.1	160
25503.8	25595.5	120	50768.9	50904.8	120
25620.5	25715.4	120	50935.4	51061.6	120
25752.0	26121.5	115	51649.7	51680.5	120
26858.8	26927.1	120	51733.5	51764.3	120
27783.6	27930.2	110	52034.0	52703.0	115
28030.4	28167.9	120	55558.0	55781.0	120
28388.0	28493.3	120	56215.0	56300.0	120
28755.7	28853.8	120	56755.0	57050.0	120
28912.0	29232.0	115	57485.0	57575.0	120
29232.0	29423.7	120	57709.0	57786.0	120
30276.9	30337.7	120	58334.0	58771.0	105
31419.1	31642.3	70	58995.0	59093.0	120
31662.4	31867.8	70	59514.0	59968.0	100
32114.2	32479.2	105	61151.0	62077.0	110
32479.2	32530.4	120	64472.0	64547.0	120
32530.4	32854.2	105	64854.0	65122.0	115
33609.6	33972.8	100	65359.0	65432.0	120
34179.7	34497.8	100	66092.0	66567.0	115
34863.8	35230.5	100	67044.0	67117.0	120
35763.4	35867.3	100	67314.0	67402.0	120
35890.0	36017.0	100	70820.0	70913.0	120
36121.5	36194.1	100	70938.0	71063.0	120
36272.1	36368.2	100	71113.0	71215.0	120
36588.3	36720.3	120	71819.0	71928.0	115
36744.0	36787.0	120	71984.0	72093.0	115
36787.0	37552.0	105	72431.0	72540.0	115
37552.0	37592.6	120	72596.0	72705.0	115

Forward			Return		
Start Dist. [m]	End Dist. [m]	Speed Limit [km/h]	Start Dist. [m]	End Dist. [m]	Speed Limit [km/h]
37772.0	38017.0	105	72905.0	73193.0	120
38017.0	38062.4	120	74495.0	74707.0	110
38282.6	38395.2	100	75166.0	75706.0	105
38422.6	38535.3	100	76233.0	76311.0	120
38602.0	38792.0	115	76453.0	76577.7	120
38792.0	38892.1	120	76603.0	76743.0	120
38915.0	39003.0	120	76939.8	77076.9	115
39099.3	39170.6	120	77076.9	77214.0	115
39195.7	39326.8	120	77235.1	77632.1	75
39347.3	39452.9	120	77836.3	77909.3	120
39494.1	39585.9	120	78874.2	78947.2	120
39693.5	40236.0	115	79441.1	79774.4	120
40384.6	40448.3	120	79833.6	80360.0	100
40458.0	40708.7	110	80403.0	80465.0	120
40708.7	40772.5	80	80542.8	80605.2	120
40772.5	40839.1	110	80818.6	81220.1	105
40839.1	40901.0	80	81220.2	81246.0	115
41196.0	41286.7	80	81246.1	81505.3	100
41332.9	41420.4	80	81505.4	81546.1	110
41640.5	41735.6	80	81546.2	81598.7	115
41758.7	41852.7	80	81623.4	81714.2	120
42426.0	42503.5	120	81740.9	81833.2	120
42503.5	42564.1	80	82077.2	82147.9	120
42564.1	42585.1	120	82170.6	82231.7	120
42585.1	42645.4	80	83391.2	83543.2	120
42851.7	42911.0	50	83845.2	84056.2	120
42932.2	42989.9	50	84171.7	84258.5	115
43108.2	43183.2	120	84294.6	84527.1	115
43204.7	43265.5	120	84527.2	84642.9	110
43861.7	43958.4	120	84670.5	84786.4	110
44485.6	44582.3	120	85104.0	85294.0	100
44803.2	44922.1	120	85357.5	85718.6	110
45197.0	45657.0	105	85783.8	85851.9	75
45657.0	45962.6	105	85876.8	85944.9	75
46196.0	46259.7	120	86124.6	86192.5	75
46353.6	46435.4	120	86217.9	86285.8	75
47264.0	47324.0	115	87056.5	87500.0	55
47324.0	47735.2	65	87845.4	87939.8	90
47781.5	47833.2	70	88025.1	88126.0	90
48432.0	48791.5	115	88397.5	88676.4	70

Forward			Return		
Start Dist. [m]	End Dist. [m]	Speed Limit [km/h]	Start Dist. [m]	End Dist. [m]	Speed Limit [km/h]
48791.5	49099.0	110	88753.6	88818.0	70
49099.0	49155.6	120	88924.0	89313.3	115
49559.6	49651.6	120	91224.1	91483.8	80
49797.9	49896.5	120	91541.4	91760.9	80
50044.3	50626.2	75	92130.6	92218.6	80
50647.4	50735.4	80	92239.8	92821.7	75
51105.1	51324.6	80	92821.7	93172.0	110
51324.6	51352.0	110	93172.0	93767.0	100
51382.2	51641.9	80	95032.8	95084.5	70
51641.9	51983.2	105	95130.8	95542.0	65
52672.1	52794.0	120	95602.0	95824.0	120
52820.2	52941.4	120	98830.6	99574.0	100
53161.9	53212.0	120	99574.0	99779.0	110
53212.0	53552.7	120	99894.0	99947.7	50
53604.5	53665.2	120	99968.2	100019.5	50
54205.5	54483.8	70	100220.7	100305.5	80
54739.2	54782.7	55	100329.3	100414.0	80
54802.9	54847.3	55	101089.0	101139.2	80
55361.5	55824.2	55	101162.6	101214.4	80
56132.0	56418.4	110	101467.9	101513.9	80
56560.7	56638.3	80	101536.3	101587.0	80
56663.3	56740.9	80	101965.0	102026.9	80
56921.0	56999.0	80	102093.4	102157.3	80
57024.0	57102.0	80	102408.0	102630.0	120
57147.0	57509.0	110	103404.0	104074.0	120
58080.0	58195.0	110	106539.6	106580.2	100
58223.0	58339.0	110	107246.5	107619.0	110
58367.0	58501.0	115	107619.0	107635.5	115
58608.0	58694.0	115	107635.5	108002.2	100
58810.0	59021.0	120	108002.2	108368.2	115
59400.0	59510.0	110	108368.2	108686.3	100
59511.0	59738.0	105	108686.3	108727.0	115
60634.0	60695.0	120	108893.2	109256.4	100
60718.0	60789.0	120	109449.0	110011.8	115
60897.0	61136.0	105	110011.8	110335.6	105
61137.0	61195.0	110	110386.8	110751.8	105
61196.0	61266.0	115	110998.2	111203.6	70
61292.0	61348.0	120	111223.7	111446.9	70
61374.0	61437.0	120	111774.0	112067.0	115
61646.0	62174.0	105	114935.8	115082.4	110

Forward			Return		
Start Dist. [m]	End Dist. [m]	Speed Limit [km/h]	Start Dist. [m]	End Dist. [m]	Speed Limit [km/h]
62175.0	62351.0	115	115114.0	115319.0	115
62401.0	62463.0	120	116094.0	116354.0	115
63092.0	63425.0	120	117654.0	117979.0	115
63811.0	64190.0	105	118836.6	119279.5	105
64191.0	64648.0	115	120604.0	120884.0	115
64957.0	65030.0	120	121874.0	122074.0	120
65234.0	65631.0	75	122183.8	122257.0	100
65690.0	65776.0	120	122280.4	122353.4	100
65797.0	65883.0	120	122584.6	122798.4	80
66158.0	66227.0	115	122798.4	122829.7	120
66278.0	66372.0	120	122829.7	122912.1	100
66453.0	66738.0	115	122912.1	123174.0	120
67160.0	67700.0	105	128284.0	129689.0	115
69011.0	69209.0	105	130554.0	130938.1	100
69673.0	69961.0	120	138946.2	139109.0	115
70161.0	70270.0	115	139659.6	139856.3	100
70326.0	70435.0	115	139886.7	140017.2	100
70773.0	70882.0	115	140599.0	140899.0	120
70938.0	71047.0	115	141782.3	141974.4	110
71651.0	71753.0	120	142012.9	142253.8	75
71803.0	71928.0	120	142282.3	142369.0	75
71953.0	72046.0	120	142550.0	142728.5	55
75464.0	75552.0	120			
75749.0	75822.0	120			
76299.0	76774.0	115			
77434.0	77507.0	120			
77604.0	77743.0	100			
77810.0	77912.0	120			
78319.0	78394.0	120			
80789.0	81715.0	110			
82898.0	83352.0	100			
83773.0	83871.0	120			
84309.0	84385.0	120			
85080.0	85157.0	120			
85291.0	85381.0	120			
85816.0	86111.0	120			
86566.0	86651.0	120			
87085.0	87308.0	120			
90149.0	90779.0	115			
91801.7	91850.3	120			

Forward			Return		
Start Dist. [m]	End Dist. [m]	Speed Limit [km/h]	Start Dist. [m]	End Dist. [m]	Speed Limit [km/h]
95306.9	95525.5	160			
95671.8	95800.8	160			
96775.2	96907.5	160			
97180.7	97409.2	160			
97711.5	97849.6	160			
98266.6	98967.5	110			
99094.2	99317.6	160			
99659.6	99865.8	160			
99897.0	100542.0	115			
100542.0	101202.6	120			
102000.8	102198.1	160			
102252.0	102662.7	115			
102730.4	102880.2	160			
103593.7	104384.9	160			
104665.9	104798.2	160			
105895.0	107643.5	160			
109599.1	111312.8	160			
111449.5	111566.8	160			
111686.6	111803.9	160			
112038.8	112203.2	160			
112526.7	112621.7	160			
112818.4	112977.1	160			
113359.3	113535.4	160			
113656.1	113773.4	160			
113953.6	114097.2	160			
114326.9	114593.9	160			
116817.4	117103.2	160			
118607.0	119000.0	160			
119495.6	119872.5	160			
121153.1	121270.9	160			
121359.5	121477.2	160			
128258.2	129116.3	160			
130883.9	131704.0	115			
131931.9	132160.3	160			
132276.1	132417.0	160			
132551.7	132683.9	160			
133069.0	133201.3	160			
134192.0	134519.4	120			
134631.1	134834.6	120			
135205.4	135430.2	120			

Forward			Return		
Start Dist. [m]	End Dist. [m]	Speed Limit [km/h]	Start Dist. [m]	End Dist. [m]	Speed Limit [km/h]
136010.6	136254.2	70			
136312.0	136343.1	115			
136343.1	136646.4	70			
136646.4	136972.0	115			
137201.9	137729.4	120			
138146.0	138352.0	120			
138352.0	138532.0	115			
138532.0	138827.0	105			
138827.0	139607.0	115			
139670.5	141360.9	80			

Appendix. J Sample data of run-curve simulation for considering the capacity of Propulsion system (Gradient for NSCR , MCRP and NSRP-South)

Forward			Return		
Start Dist. [m]	End Dist. [m]	Gradient [%]	Start Dist. [m]	End Dist. [m]	Gradient [%]
0	232	0	0	2602	-2
232	712	-5	2602	2840	20
712	1052	0	2840	3035.16	0
1052	1332	-5	3035.16	3259	5
1332	1967	0	3259	4039	10
1967	2267	8	4039	4334	34
2267	3510	0	4334	4514	10
3510	3840	5	4514	4972.68	-3
3840	4032	0	4972.68	5434	-10
4032	4162	5	5434	5894	-20
4162	4702	0	5894	6554	10
4702	6159.5	-5	6554	6951.5	4
6159.5	6917	5	6951.5	8134	0
6917	7287	0	8134	9927.75	-8
7287	8080.182	-6	9927.75	10334	0
8080.182	8532	5	10334	10965.25	-2
8532	8917	0	10965.25	11829	-10
8917	9457.5	-5	11829	12614	-5
9457.5	9719	-25	12614	12876.5	-9
9719	10514	-2	12876.5	13334	-5
10514	11112	5	13334	14819	-10
11112	11692	-2	14819	15734	-5
11692	13177	2	15734	16084	0
13177	14582	6	16084	16444	-10
14582	15097	0	16444	19394	-5
15097	15265.85	-5	19394	19994	-10
15265.85	15502	-25	19994	23434	-5
15502	15957	-4	23434	23834	0
15957	17291	2	23834	24084	-5
17291	17527	0	24084	25194	0
17527	17707	5	25194	25664	-10
17707	17992	0	25664	25914	5
17992	18304	-25	25914	26264	14
18304	18897	0	26264	26827	-15
18897	19397	-2	26827	27228	-5
19397	19692	0	27228	28734	0
19692	20172	10	28734	28994	-10
20172	20792	0	28994	29234	-5
20792	20992	10	29234	31274	0
20992	21982	0	31274	31674	5

Forward			Return		
Start Dist. [m]	End Dist. [m]	Gradient [%]	Start Dist. [m]	End Dist. [m]	Gradient [%]
21982	22262	25	31674	32144	-5
22262	22562	5	32144	32634	5
22562	23146	-25	32634	32984	0
23146	24152	0	32984	33134	5
24152	24352	-6	33134	33674	-5
24352	24887	0	33674	33884	5
24887	25212	24	33884	34034	0
25212	25498	0	34034	34474	-5
25498	25752	-3	34474	35134	5
25752	26121.52	-25	35134	35734	0
26121.52	26512	0	35734	36074	-5
26512	26772	10	36074	37334	0
26772	27547	0	37334	37474	-10
27547	27752	20	37474	38840	0
27752	28012	5	38840	39094	10
28012	28912	0	39094	39414	-5
28912	29232	-24	39414	40203.3	0
29232	30799	0	40203.3	40614	15
30799	31092	10	40614	41034	0
31092	31762	5	41034	41534	-10
31762	32252	0	41534	41774	-5
32252	32672	-15	41774	42324	0
32672	33417	10	42324	42969	10
33417	34139	5	42969	43274	0
34139	35247	10	43274	43654	-12
35247	35619.5	16	43654	43840.25	-8
35619.5	36787	0	43840.25	44099	0
36787	37552	-20	44099	44434	10
37552	37772	-5	44434	45404	0
37772	38017	-20	45404	45799	-10
38017	38337	0	45799	49745	0
38337	38602	-5	49745	50134	10
38602	38792	-8	50134	52034	0
38792	39462	6	52034	52427	-10
39462	39693.5	2	52427	52969	3
39693.5	40236	-10	52969	53372	-3
40236	40458	30	53372	54114	1
40458	40859	-34	54114	54371	-1
40859	41146.25	-4	54371	55034	2
41146.25	42182.4	0	55034	55814	0

Forward			Return		
Start Dist. [m]	End Dist. [m]	Gradient [%o]	Start Dist. [m]	End Dist. [m]	Gradient [%o]
42182.4	42426	5	55814	57101	2
42426	42610	-12	57101	57614	5
42610	43087	0	57614	57994	1
43087	43292	14	57994	58334	0
43292	44035.42	24	58334	58771	-20
44035.421	44467	5	58771	58974	-1
44467	44937	0	58974	59984	2
44937	45197	-5	59984	60374	-2
45197	45657	-24	60374	60834	0
45657	45962.63	-16	60834	61374	-1
45962.625	47042	0	61374	61674	-2
47042	47264	20	61674	61854	1
47264	47432	-10	61854	62174	-1
47432	48432	0	62174	62534	2
48432	48791.5	-8	62534	62994	0
48791.5	49099	-34	62994	63634	1
49099	49694	29	63634	64005	-1
49694	50337.6	15	64005	64371	1
50337.6	50752	5	64371	64854	-1
50752	51212	0	64854	65122	-10
51212	51352	-12	65122	65261	25
51352	51983.2	-23	65261	65814	3
51983.2	52882.4	3	65814	66634	-1
52882.4	53212	0	66634	67242	0
53212	53552.667	-6	67242	67934	1
53552.667	53942	24	67934	69238	-1
53942	55550	0	69238	69534	1
55550	55732	-10	69534	69814	0
55732	56132	-5	69814	70035	-2
56132	56418.4	-25	70035	70274	1
56418.4	57056	0	70274	70674	-1
57056	57259	-4	70674	72039	2
57259	57572	1	72039	72485	0
57572	57762	25	72485	73320	-4
57762	58052	0	73320	73656	1
58052	58281	-1	73656	73854	20
58281	58571	8	73854	74215	0
58571	58790	-5	74215	74495	-1
58790	59401	0	74495	74707	-15
59401	59512	-15	74707	75430	2

Forward			Return		
Start Dist. [m]	End Dist. [m]	Gradient [%o]	Start Dist. [m]	End Dist. [m]	Gradient [%o]
59512	59739	-20	75430	76127	-5
59739	60206	0	76127	76412	10
60206	60619	4	76412	76674	3
60619	60898	-2	76674	77322.2	0
60898	61138	-19	77322.2	77469.5	-15
61138	61197	-12	77469.5	78217	-1
61197	61267	-7	78217	78674	10
61267	61320	8	78674	79054	20
61320	61361	15	79054	79833.6	0
61361	61503	22	79833.6	80360	-25
61503	61620	25	80360	80514	0
61620	61833	10	80514	80689.8	8
61833	62176	-18	80689.8	81033.3	18
62176	62352	-8	81033.3	81246.1	-10
62352	62506	0	81246.1	81363.3	-25
62506	63032	25	81363.3	81505.4	-22
63032	63812	0	81505.4	81546.2	-15
63812	64192	-20	81546.2	81598.7	-8
64192	64649	-10	81598.7	81669	7
64649	65397	1	81669	81727.6	12
65397	65544	15	81727.6	81967.9	19
65544	66192	0	81967.9	82246.7	2
66192	66454	-3	82246.7	82659.6	-4
66454	66739	-10	82659.6	83127.3	0
66739	67436	5	83127.3	83354	20
67436	68159	-2	83354	83465.1	15
68159	68371	15	83465.1	84075.8	0
68371	68651	1	84075.8	84294.6	5
68651	69012	0	84294.6	84585	-8
69012	69210	-20	84585	84814	1
69210	69546	-1	84814	85104	0
69546	70381	4	85104	85294	-25
70381	70827	0	85294	85606.8	-1
70827	72192	-2	85606.8	85810	4
72192	72592	1	85810	86447.6	0
72592	72831	-1	86447.6	86734	25
72831	73052	2	86734	87134	5
73052	73332	0	87134	87316	10
73332	73628	-1	87316	88924	0
73628	74932	1	88924	89313.3	-24

Forward			Return		
Start Dist. [m]	End Dist. [m]	Gradient [‰]	Start Dist. [m]	End Dist. [m]	Gradient [‰]
74932	75624	-1	89313.3	89654	6
75624	76232	0	89654	89983.6	0
76232	77052	1	89983.6	90882.8	-3
77052	77605	-3	90882.8	91514	23
77605	77744	-25	91514	91654	12
77744	78012	10	91654	92114	0
78012	78495	1	92114	92528.4	-5
78495	78861	-1	92528.4	93172	-15
78861	79232	1	93172	93767	-29
79232	79872	-1	93767	94074.5	34
79872	80332	0	94074.5	94434	8
80332	80692	-2	94434	95434	0
80692	81012	1	95434	95602	10
81012	81192	-1	95602	95824	-20
81192	81492	2	95824	96903.4	0
81492	82032	1	96903.4	97209	16
82032	82492	0	97209	97669	24
82492	82882	2	97669	97929	5
82882	83892	-2	97929	98399	0
83892	84095	1	98399	98830.6	-5
84095	84532	20	98830.6	99574	-24
84532	84872	0	99574	99779	-14
84872	85252	-1	99779	100256	0
85252	85765	-5	100256	100440	12
85765	87052	-2	100440	100683.6	-5
87052	87832	0	100683.6	101719.8	0
87832	88495	-2	101719.8	102007	4
88495	88752	1	102007	102408	34
88752	89494	-1	102408	102630	-30
89494	89897	3	102630	103172.5	10
89897	90439	-3	103172.5	103404	-2
90439	90832	10	103404	104074	-6
90832	92732	0	104074	104264	8
92732	93121	-10	104264	104529	5
93121	97067	0	104529	104849	0
97067	97462	10	104849	105094	20
97462	98432	0	105094	105314	5
98432	98767	-10	105314	106079	20
98767	99025.75	0	106079	107246.5	0
99025.75	99212	8	107246.5	107619	-16

Forward			Return		
Start Dist. [m]	End Dist. [m]	Gradient [‰]	Start Dist. [m]	End Dist. [m]	Gradient [‰]
99212	99592	12	107619	108727	-10
99592	99897	0	108727	109449	-5
99897	100542	-10	109449	110194	-10
100542	101092	0	110194	110614	15
101092	101332	5	110614	111104	0
101332	101832	10	111104	111774	-5
101832	102252	0	111774	112067	-10
102252	102662.7	-15	112067	113634	0
102662.7	103452	0	113634	113954	24
103452	103772	5	113954	114854	0
103772	104026	-10	114854	115114	-5
104026	105392	0	115114	115319	-20
105392	105532	10	115319	116094	0
105532	106792	0	116094	116354	-10
106792	107132	5	116354	116744.5	0
107132	107732	0	116744.5	117114	25
107732	108392	-5	117114	117368	3
108392	108832	5	117368	117654	0
108832	108982	0	117654	117979	-24
108982	109192	-5	117979	118514	0
109192	109732	5	118514	118714	6
109732	109882	-5	118714	119720	0
109882	110232	0	119720	120304	25
110232	110722	-5	120304	120604	-5
110722	111192	5	120604	120884	-25
111192	111592	-5	120884	121874	0
111592	113632	0	121874	122074	-10
113632	113872	5	122074	122694	0
113872	114132	10	122694	123174	-10
114132	115638	0	123174	123469	0
115638	116039	5	123469	123969	2
116039	116602	15	123969	124562	0
116602	116952	-14	124562	124874	25
116952	117202	-5	124874	125159	0
117202	117672	10	125159	125339	-5
117672	118782	0	125339	125575	0
118782	119032	5	125575	126909	-2
119032	119432	0	126909	127364	4
119432	122872	5	127364	127600.2	25
122872	123472	10	127600.2	127769	5

Forward			Return		
Start Dist. [m]	End Dist. [m]	Gradient [‰]	Start Dist. [m]	End Dist. [m]	Gradient [‰]
123472	126422	5	127769	128284	0
126422	126782	10	128284	129689	-6
126782	127132	0	129689	131174	-2
127132	128047	5	131174	131754	2
128047	129532	10	131754	132352	-5
129532	129989.5	5	132352	133147	2
129989.5	130252	9	133147	133408.5	25
130252	131037	5	133408.5	133949	5
131037	131900.75	10	133949	134334	0
131900.75	132532	2	134334	134785.8	-5
132532	132938.25	0	134785.8	135579	6
132938.25	134732	8	135579	135949	0
134732	135914.5	0	135949	136706.5	-5
135914.5	136312	-4	136706.5	138164	5
136312	136972	-10	138164	138704	0
136972	137432	20	138704	138834	-5
137432	137893.32	10	138834	139026	0
137893.32	138352	3	139026	139356	-5
138352	138532	-10	139356	140599	0
138532	138827	-34	140599	140899	-8
138827	139607	-10	140899	141534	0
139607	139830.84	-5	141534	141814	5
139830.84	140026	0	141814	142154	0
140026	140264	-20	142154	142634	5
140264	142866	2	142634	142866	0

Appendix. K Sample data of run-curve simulation for considering the capacity of Propulsion system (Curvature Radius for Interoperability)

Forward			Return		
Start Dist. [m]	End Dist. [m]	Curvature Radius [m]	Start Dist. [m]	End Dist. [m]	Curvature Radius [m]
0	135.8273	0	0	457.62313	0
135.8273	315.3181	-261	457.62313	504.77596	4500
315.3181	505.1298	0	504.77596	530.29392	0
505.1298	591.4698	-800	530.29392	577.44676	-4500
591.4698	612.1436	0	577.44676	1499.78454	0
612.1436	853.1046	304	1499.78454	3200.82249	-640
853.1046	891.6747	0	3200.82249	3910.88548	0
891.6747	1083.715	804	3910.88548	4291.99383	1204
1083.715	2181.1298	0	4291.99383	4371.18013	0
2181.1298	2244.7971	5004	4371.18013	4719.99339	-1200
2244.7971	2366.609	0	4719.99339	5136.61876	0
2366.609	2514.4688	-1400	5136.61876	5664.10437	-1500
2514.4688	2547.9003	0	5664.10437	6219.60976	0
2547.9003	2682.8934	1404	6219.60976	6522.9259	354
2682.8934	2848.7628	0	6522.9259	6611.76349	0
2848.7628	2979.143	1004	6611.76349	6855.41726	-350
2979.143	3009.5783	0	6855.41726	7435.75242	0
3009.5783	3206.4132	-600	7435.75242	7660.57508	1704
3206.4132	3448.0708	0	7660.57508	8031.36182	0
3448.0708	3571.6789	1804	8031.36182	8234.9113	-1200
3571.6789	3593.6366	0	8234.9113	8346.60953	0
3593.6366	3724.6036	-1800	8346.60953	8674.03727	1204
3724.6036	3756.9937	0	8674.03727	9664.74226	0
3756.9937	3919.9175	1104	9664.74226	9796.97421	5000
3919.9175	3959.7782	0	9796.97421	10182.00708	0
3959.7782	4115.0388	-1300	10182.00708	10314.37866	-5004
4115.0388	4558.1187	0	10314.37866	10448.89583	0
4558.1187	4639.3807	-4000	10448.89583	10589.92727	-5004
4639.3807	5241.0972	0	10589.92727	10705.81239	0
5241.0972	5322.3592	4004	10705.81239	10933.96955	5000
5322.3592	6377.2252	0	10933.96955	11162.00692	0
6377.2252	6480.8041	-2500	11162.00692	11982.10209	1104
6480.8041	6557.1733	0	11982.10209	13749.71787	0
6557.1733	6713.1384	1504	13749.71787	14607.83935	-1800
6713.1384	6861.9189	0	14607.83935	21388.76535	0
6861.9189	6972.2537	-2000	21388.76535	21506.51688	-5000
6972.2537	7226.2202	0	21506.51688	21595.12388	0
7226.2202	7336.555	-2000	21595.12388	21712.87542	5004
7336.555	7491.0521	0	21712.87542	22993.49921	0
7491.0521	7597.5869	2004	22993.49921	23370.39257	-1800

Forward			Return		
Start Dist. [m]	End Dist. [m]	Curvature Radius [m]	Start Dist. [m]	End Dist. [m]	Curvature Radius [m]
7597.5869	8181.4232	0	23370.39257	23866.01268	0
8181.4232	8342.598	1304	23866.01268	24258.96782	2204
8342.598	8455.531	0	24258.96782	25762.82709	0
8455.531	8614.854	-1300	25762.82709	26048.55916	2504
8614.854	8835.023	0	26048.55916	28272.11875	0
8835.023	8998.7767	-1200	28272.11875	28539.14903	2504
8998.7767	9109.2742	0	28539.14903	28768.75933	0
9109.2742	9270.7239	1204	28768.75933	28912.35783	5004
9270.7239	11823.1749	0	28912.35783	29092.64161	0
11823.1749	11905.57	-3000	29092.64161	29209.93724	-6000
11905.57	11927.9212	0	29209.93724	29330.5821	0
11927.9212	12312.0219	604	29330.5821	29506.67174	6004
12312.0219	12332.2452	0	29506.67174	29888.9161	0
12332.2452	12430.3587	-3000	29888.9161	30047.64258	-6000
12430.3587	14327.5952	0	30047.64258	30244.25321	0
14327.5952	14391.2625	-5000	30244.25321	30339.28004	-6000
14391.2625	14416.9775	0	30339.28004	30662.79074	0
14416.9775	14506.1176	3304	30662.79074	30827.20836	5004
14506.1176	14594.9823	0	30827.20836	31062.14446	0
14594.9823	14659.9814	-5000	31062.14446	31179.4401	-6000
14659.9814	15065.8926	0	31179.4401	31299.24035	0
15065.8926	15127.892	-5000	31299.24035	31416.53598	6004
15127.892	15150.7149	0	31416.53598	31553.22952	0
15150.7149	15215.0662	5004	31553.22952	33266.89223	-2500
15215.0662	15669.2789	0	33266.89223	35222.49968	0
15669.2789	15735.2461	-5000	35222.49968	36971.02152	1804
15735.2461	16095.1959	0	36971.02152	38067.81744	0
16095.1959	16177.8778	3004	38067.81744	38200.11921	5004
16177.8778	16582.4801	0	38200.11921	38481.08061	0
16582.4801	16646.1309	-5000	38481.08061	39272.27647	-1800
16646.1309	16646.1309	0	39272.27647	39985.83698	0
16646.1309	19953.8713	0	39985.83698	40135.58139	-4000
19953.8713	20036.3023	1504	40135.58139	40667.91487	0
20036.3023	20067.6121	0	40667.91487	40865.16297	2804
20067.6121	20281.3707	-350	40865.16297	41663.43073	0
20281.3707	20512.5738	0	41663.43073	42442.30138	-1200
20512.5738	20585.6143	-2200	42442.30138	43000.18505	0
20585.6143	20609.0084	0	43000.18505	43206.36767	-2600
20609.0084	20682.1911	2204	43206.36767	43548.35597	0
20682.1911	21026.6445	0	43548.35597	43771.78421	-2500

Forward			Return		
Start Dist. [m]	End Dist. [m]	Curvature Radius [m]	Start Dist. [m]	End Dist. [m]	Curvature Radius [m]
21026.6445	21145.4407	1804	43771.78421	43898.49014	0
21145.4407	21247.9414	0	43898.49014	44599.37113	804
21247.9414	21366.8539	-1800	44599.37113	45016.40705	0
21366.8539	21587.142	0	45016.40705	45154.53843	4004
21587.142	21712.4068	-1600	45154.53843	45456.81664	0
21712.4068	21803.768	0	45456.81664	45685.26562	-3000
21803.768	21942.3188	1500	45685.26562	45958.50728	0
21942.3188	22295.7653	0	45958.50728	46090.80904	5004
22295.7653	22397.0368	-2004	46090.80904	47065.18175	0
22397.0368	22428.1472	0	47065.18175	47194.16706	4004
22428.1472	22515.9805	3000	47194.16706	47340.52036	0
22515.9805	23586.5221	0	47340.52036	47559.05428	-3500
23586.5221	24029.4302	-750	47559.05428	50768.86642	0
24029.4302	24552.7376	0	50768.86642	50904.83805	-2000
24552.7376	24616.3883	5004	50904.83805	50935.42232	0
24616.3883	25052.929	0	50935.42232	51061.64791	2000
25052.929	25116.5797	-5000	51061.64791	51649.69048	0
25116.5797	25503.759	0	51649.69048	51680.5242	-18000
25503.759	25595.5283	2504	51680.5242	51733.53809	0
25595.5283	25620.5156	0	51733.53809	51764.29656	18000
25620.5156	25715.3861	-2500	51764.29656	52074	0
25715.3861	26858.796	0	52074	52703	1004
26858.796	26927.098	4504	52703	55558	0
26927.098	27783.6114	0	55558	55781	1204
27783.6114	27930.1608	-1400	55781	56215	0
27930.1608	28030.3787	0	56215	56300	5000
28030.3787	28167.8682	1604	56300	56755	0
28167.8682	28387.9706	0	56755	57050	1200
28387.9706	28493.3067	2204	57050	57485	0
28493.3067	28755.6832	0	57485	57575	4000
28755.6832	28853.8404	-2500	57575	57709	0
28853.8404	29100.9111	0	57709	57786	5004
29100.9111	29423.6645	-2500	57786	58481	0
29423.6645	30276.9169	0	58481	58557	5000
30276.9169	30337.6575	5004	58557	58995	0
30337.6575	31419.0857	0	58995	59093	3204
31419.0857	31642.346	-280	59093	59514	0
31642.346	31662.3794	0	59514	59968	654
31662.3794	31867.8262	284	59968	61151	0
31867.8262	32114.1675	0	61151	62077	900

Forward			Return		
Start Dist. [m]	End Dist. [m]	Curvature Radius [m]	Start Dist. [m]	End Dist. [m]	Curvature Radius [m]
32114.1675	32479.172	704	62077	64472	0
32479.172	32530.375	0	64472	64547	5000
32530.375	32854.1521	-700	64547	64954	0
32854.1521	33609.5727	0	64954	65056	3504
33609.5727	33972.7775	604	65056	65359	0
33972.7775	34179.6774	0	65359	65432	5000
34179.6774	34497.7949	-600	65432	66092	0
34497.7949	34863.7939	0	66092	66567	1100
34863.7939	35230.4612	604	66567	67044	0
35230.4612	35763.4274	0	67044	67117	5004
35763.4274	35867.309	-1200	67117	67314	0
35867.309	35890.0377	0	67314	67402	5000
35890.0377	36016.9504	950	67402	70820	0
36016.9504	36121.4666	0	70820	70913	3204
36121.4666	36194.0681	-2000	70913	70938	0
36194.0681	36272.1417	0	70938	71063	2100
36272.1417	36368.196	1400	71063	71113	0
36368.196	36588.3162	0	71113	71215	4004
36588.3162	36720.3321	1500	71215	71819	0
36720.3321	36744.0151	0	71819	71928	1804
36744.0151	36867.6672	-1700	71928	71984	0
36867.6672	37226.8803	0	71984	72093	1800
37226.8803	37398.8551	1200	72093	72431	0
37398.8551	37419.9526	0	72431	72540	1800
37419.9526	37592.5597	-1200	72540	72596	0
37592.5597	37836.8585	0	72596	72705	1804
37836.8585	37940.8782	-2000	72705	72905	0
37940.8782	37961.8583	0	72905	73193	2000
37961.8583	38062.3887	2000	73193	75166	0
38062.3887	38282.5585	0	75166	75706	750
38282.5585	38395.2261	1000	75706	76233	0
38395.2261	38422.63	0	76233	76311	5000
38422.63	38535.3337	-1000	76311	76453	0
38535.3337	38648.44	0	76453	76577.72707	1500
38648.44	38709.2006	5004	76577.72707	76603	0
38709.2006	38790.0233	0	76603	76743.02841	1500
38790.0233	38892.0596	-2000	76743.02841	76939.83239	0
38892.0596	38914.9597	0	76939.83239	77076.92549	1300
38914.9597	39003.0295	3004	77076.92549	77076.92549	0
39003.0295	39099.2644	0	77076.92549	77214.01859	1300

Forward			Return		
Start Dist. [m]	End Dist. [m]	Curvature Radius [m]	Start Dist. [m]	End Dist. [m]	Curvature Radius [m]
39099.2644	39170.5574	-4000	77214.01859	77235.09463	0
39170.5574	39195.6985	0	77235.09463	77632.10393	654
39195.6985	39326.7822	1504	77632.10393	77836.30285	0
39326.7822	39347.2655	0	77836.30285	77909.31691	5000
39347.2655	39452.9088	-2000	77909.31691	78874.22443	0
39452.9088	39494.0659	0	78874.22443	78947.23719	5004
39494.0659	39585.8787	2504	78947.23719	79441.09556	0
39585.8787	39766.8764	0	79441.09556	79774.42474	1204
39766.8764	39871.4393	-1900	79774.42474	80402.9635	0
39871.4393	40158.8487	0	80402.9635	80465.03433	5004
40158.8487	40219.6049	5004	80465.03433	80542.76095	0
40219.6049	40384.6362	0	80542.76095	80605.24813	5000
40384.6362	40448.3247	5004	80605.24813	80818.62267	0
40448.3247	40708.7063	0	80818.62267	81220.10734	700
40708.7063	40772.5261	-1200	81220.10734	81428.745	0
40772.5261	40839.1014	0	81428.745	81492.39572	5000
40839.1014	40900.96	1504	81492.39572	81518.43651	0
40900.96	41195.9552	0	81518.43651	81573.9308	5304
41195.9552	41286.6878	-750	81573.9308	81623.40566	0
41286.6878	41332.8936	0	81623.40566	81714.21577	2304
41332.8936	41420.3664	800	81714.21577	81740.85133	0
41420.3664	41640.5298	0	81740.85133	81833.23013	2300
41640.5298	41735.6433	700	81833.23013	82077.1629	0
41735.6433	41758.7459	0	82077.1629	82147.90978	5004
41758.7459	41852.7021	-700	82147.90978	82170.57378	0
41852.7021	42503.5092	0	82170.57378	82231.68806	5000
42503.5092	42564.0675	-1500	82231.68806	83391.23085	0
42564.0675	42585.0942	0	83391.23085	83543.15038	2004
42585.0942	42645.3569	1500	83543.15038	83845.23884	0
42645.3569	42851.6821	0	83845.23884	84056.15869	1504
42851.6821	42911.0378	600	84056.15869	84171.6954	0
42911.0378	42932.157	0	84171.6954	84258.48965	6004
42932.157	42989.9315	-600	84258.48965	84365.1497	0
42989.9315	43108.185	0	84365.1497	84498.4447	1600
43108.185	43183.2041	-4000	84498.4447	84527.20208	0
43183.2041	43204.7176	0	84527.20208	84642.87649	1500
43204.7176	43265.4654	5004	84642.87649	84670.45066	0
43265.4654	43861.7016	0	84670.45066	84786.3964	1504
43861.7016	43958.3536	-2500	84786.3964	85357.46009	0
43958.3536	44485.6115	0	85357.46009	85718.56291	800

Forward			Return		
Start Dist. [m]	End Dist. [m]	Curvature Radius [m]	Start Dist. [m]	End Dist. [m]	Curvature Radius [m]
44485.6115	44582.2661	2504	85718.56291	85783.7892	0
44582.2661	44803.1705	0	85783.7892	85851.86861	1100
44803.1705	44922.0872	1804	85851.86861	85876.8336	0
44922.0872	45315.652	0	85876.8336	85944.91301	1100
45315.652	45420.8405	-2200	85944.91301	86124.5606	0
45420.8405	45734.4496	0	86124.5606	86192.4815	-1100
45734.4496	45812.9565	-4000	86192.4815	86217.9132	0
45812.9565	46196.0364	0	86217.9132	86285.834	1100
46196.0364	46259.6663	-5000	86285.834	87056.4963	0
46259.6663	46353.5976	0	87056.4963	87500.0126	-261
46353.5976	46435.3531	4004	87500.0126	87845.3597	0
46435.3531	47324.012	0	87845.3597	87939.8446	1000
47324.012	47735.2196	-300	87939.8446	88025.0933	0
47735.2196	47781.4507	0	88025.0933	88125.9524	-900
47781.4507	47833.164	-1200	88125.9524	88397.4515	0
47833.164	48692.4171	0	88397.4515	88676.4069	300
48692.4171	48870.358	1254	88676.4069	88753.5535	0
48870.358	48992.0863	0	88753.5535	88818.0363	1000
48992.0863	49155.6148	-1350	88818.0363	89200.7503	0
49155.6148	49559.6493	0	89200.7503	89261.491	5000
49559.6493	49651.6192	-2500	89261.491	89487.4024	0
49651.6192	49797.9416	0	89487.4024	89577.9459	2500
49797.9416	49896.4627	2504	89577.9459	89600.0717	0
49896.4627	50044.2978	0	89600.0717	89704.1492	-2004
50044.2978	50626.2202	314	89704.1492	89924.5799	0
50626.2202	50647.397	0	89924.5799	90045.8297	-1604
50647.397	50735.4477	-900	90045.8297	90072.1128	0
50735.4477	51105.1095	0	90072.1128	90193.9482	1650
51105.1095	51324.6045	354	90193.9482	91224.1052	0
51324.6045	51382.1507	0	91224.1052	91483.8423	-354
51382.1507	51641.9018	-350	91483.8423	91541.3891	0
51641.9018	52672.0518	0	91541.3891	91760.8969	350
52672.0518	52793.9637	1654	91760.8969	92130.5523	0
52793.9637	52820.2367	0	92130.5523	92218.603	-904
52820.2367	52941.4201	-1600	92218.603	92239.7634	0
52941.4201	53161.8508	0	92239.7634	92821.7186	310
53161.8508	53265.832	-2000	92821.7186	92969.5373	0
53265.832	53287.9652	0	92969.5373	93068.0584	2500
53287.9652	53378.5976	2504	93068.0584	93214.38	0
53378.5976	53604.509	0	93214.38	93306.3259	-2504

Forward			Return		
Start Dist. [m]	End Dist. [m]	Curvature Radius [m]	Start Dist. [m]	End Dist. [m]	Curvature Radius [m]
53604.509	53665.2497	5004	93306.3259	93710.3779	0
53665.2497	54205.5165	0	93710.3779	93874.1836	-1354
54205.5165	54483.7723	300	93874.1836	93995.9118	0
54483.7723	54739.1703	0	93995.9118	94173.5244	1250
54739.1703	54782.7051	1700	94173.5244	95032.836	0
54782.7051	54802.8669	0	95032.836	95084.5493	-1204
54802.8669	54847.2818	-1200	95084.5493	95130.788	0
54847.2818	55361.5367	0	95130.788	95541.9804	-304
55361.5367	55824.2282	-261	95541.9804	96430.6469	0
55824.2282	56560.6905	0	96430.6469	96512.3457	4000
56560.6905	56638.2734	-1000	96512.3457	96606.277	0
56638.2734	56663.2692	0	96606.277	96669.9418	-5004
56663.2692	56740.8521	1000	96669.9418	97053.1567	0
56740.8521	56921	0	97053.1567	97131.6241	-4004
56921	56999	1000	97131.6241	97445.1595	0
56999	57024	0	97445.1595	97550.4095	-2204
57024	57102	1000	97550.4095	97943.9128	0
57102	57147	0	97943.9128	98062.8295	1800
57147	57509	804	98062.8295	98283.7339	0
57509	58080	0	98283.7339	98380.3885	2500
58080	58195	1500	98380.3885	98907.5712	0
58195	58223	0	98907.5712	99004.2984	-2504
58223	58339	1504	99004.2984	99600.5346	0
58339	58367	0	99600.5346	99661.2824	5000
58367	58501	1604	99661.2824	99682.7959	0
58501	58608	0	99682.7959	99757.815	-4004
58608	58694	6000	99757.815	99893.9992	0
58694	58810	0	99893.9992	99947.6655	900
58810	59021	1500	99947.6655	99968.2447	0
59021	59323	0	99968.2447	100019.4601	-900
59323	59475	2000	100019.4601	100220.6593	0
59475	60634	0	100220.6593	100305.4713	-900
60634	60695	5004	100305.4713	100329.2682	0
60695	60718	0	100329.2682	100413.9924	900
60718	60789	5000	100413.9924	101088.9724	0
60789	61033	0	101088.9724	101139.2372	-2500
61033	61125	2304	101139.2372	101162.6276	0
61125	61152	0	101162.6276	101214.4452	2200
61152	61243	2300	101214.4452	101467.8612	0
61243	61292	0	101467.8612	101513.8564	2300

Forward			Return		
Start Dist. [m]	End Dist. [m]	Curvature Radius [m]	Start Dist. [m]	End Dist. [m]	Curvature Radius [m]
61292	61348	5300	101513.8564	101536.3277	0
61348	61374	0	101536.3277	101586.9531	-2300
61374	61437	5004	101586.9531	101965.0406	0
61437	61646	0	101965.0406	102026.9275	1500
61646	62047	704	102026.9275	102093.3885	0
62047	62261	0	102093.3885	102157.2937	-1204
62261	62323	5004	102157.2937	102417.6753	0
62323	62401	0	102417.6753	102481.3288	5000
62401	62463	5000	102481.3288	102646.3961	0
62463	63092	0	102646.3961	102707.1198	5000
63092	63425	1200	102707.1198	102994.5291	0
63425	63919	0	102994.5291	103099.228	-1904
63919	63992	5000	103099.228	103280.1568	0
63992	64957	0	103280.1568	103371.874	2500
64957	65030	5004	103371.874	103413.0311	0
65030	65234	0	103413.0311	103518.8139	-2004
65234	65631	650	103518.8139	103539.322	0
65631	65690	0	103539.322	103670.2553	1500
65690	65776	3000	103670.2553	103695.3963	0
65776	65797	0	103695.3963	103766.7356	-4004
65797	65883	3000	103766.7356	103862.9705	0
65883	66158	0	103862.9705	103950.9612	3000
66158	66227	5000	103950.9612	103973.8407	0
66227	66278	0	103973.8407	104075.9537	-2004
66278	66372	3000	104075.9537	104156.8138	0
66372	66555	0	104156.8138	104217.5519	5000
66555	66633	5004	104217.5519	104804.1061	0
66633	67160	0	104804.1061	104924.254	-1700
67160	67700	754	104924.254	104946.995	0
67700	69673	0	104946.995	105063.1391	1800
69673	69961	2004	105063.1391	105307.6873	0
69961	70161	0	105307.6873	105411.5445	2000
70161	70270	1800	105411.5445	105437.5881	0
70270	70326	0	105437.5881	105542.4649	-2000
70326	70435	1804	105542.4649	106140.8822	0
70435	70773	0	106140.8822	106201.6044	5000
70773	70882	1804	106201.6044	106539.6106	0
70882	70938	0	106539.6106	106580.1536	-5000
70938	71047	1800	106580.1536	106973.9466	0
71047	71651	0	106973.9466	107109.4205	1500

Forward			Return		
Start Dist. [m]	End Dist. [m]	Curvature Radius [m]	Start Dist. [m]	End Dist. [m]	Curvature Radius [m]
71651	71753	4000	107109.4205	107635.5369	0
71753	71803	0	107635.5369	108002.208	600
71803	71928	2104	108002.208	108368.2068	0
71928	71953	0	108368.2068	108686.3208	-604
71953	72046	3200	108686.3208	108893.2206	0
72046	75464	0	108893.2206	109256.4292	600
75464	75552	5004	109256.4292	110011.8489	0
75552	75749	0	110011.8489	110335.6241	-704
75749	75822	5000	110335.6241	110386.827	0
75822	76299	0	110386.827	110751.8335	700
76299	76774	1104	110751.8335	110998.1635	0
76774	77434	0	110998.1635	111203.6309	280
77434	77507	5004	111203.6309	111223.6647	0
77507	77810	0	111223.6647	111446.9036	-284
77810	77912	3500	111446.9036	112528.3425	0
77912	78319	0	112528.3425	112589.0831	5000
78319	78394	5004	112589.0831	113442.3355	0
78394	80789	0	113442.3355	113765.0889	-2504
80789	81715	904	113765.0889	114012.1596	0
81715	82898	0	114012.1596	114110.3168	-2504
82898	83352	650	114110.3168	114372.6933	0
83352	83773	0	114372.6933	114478.0294	2200
83773	83871	3200	114478.0294	114698.1318	0
83871	84309	0	114698.1318	114835.6213	1600
84309	84385	5004	114835.6213	114935.8393	0
84385	85080	0	114935.8393	115082.3885	-1404
85080	85157	5000	115082.3885	115938.902	0
85157	85291	0	115938.902	116007.204	4500
85291	85381	4004	116007.204	117150.6139	0
85381	85816	0	117150.6139	117245.4844	-2504
85816	86111	1204	117245.4844	117270.4717	0
86111	86566	0	117270.4717	117362.241	2500
86566	86651	5004	117362.241	117749.4203	0
86651	87085	0	117749.4203	117813.071	-5004
87085	87308	1200	117813.071	118249.6117	0
87308	90149	0	118249.6117	118313.2624	5000
90149	90779	1000	118313.2624	118836.5705	0
90779	91801.6727	0	118836.5705	119279.4772	-754
91801.6727	91850.31611	-8000	119279.4772	120349.9423	0
91850.31611	95306.94573	0	120349.9423	120437.93	3004

Forward			Return		
Start Dist. [m]	End Dist. [m]	Curvature Radius [m]	Start Dist. [m]	End Dist. [m]	Curvature Radius [m]
95306.94573	95525.47963	-3504	120437.93	120469.0853	0
95525.47963	95671.83294	0	120469.0853	120570.1125	-2000
95671.83294	95800.81825	4000	120570.1125	120923.458	0
95800.81825	96775.19096	0	120923.458	121062.4551	1504
96775.19096	96907.49272	5000	121062.4551	121153.5932	0
96907.49272	97180.73439	0	121153.5932	121278.8579	-1604
97180.73439	97409.18335	-3004	121278.8579	121499.1461	0
97409.18335	97711.46157	0	121499.1461	121618.0586	-1804
97711.46157	97849.59295	4000	121618.0586	121720.5593	0
97849.59295	98266.62658	0	121720.5593	121839.3555	1800
98266.62658	98967.51215	800	121839.3555	122183.8089	0
98967.51215	99094.21581	0	122183.8089	122256.9916	2200
99094.21581	99317.64401	-2504	122256.9916	122280.3857	0
99317.64401	99659.63235	0	122280.3857	122353.4262	-2204
99659.63235	99865.81494	-2604	122353.4262	122584.6357	0
99865.81494	100423.699	0	122584.6357	122798.3816	-354
100423.699	101202.5689	-1204	122798.3816	122829.6977	0
101202.5689	102000.837	0	122829.6977	122912.1287	1500
102000.837	102198.0851	2800	122912.1287	126219.8691	0
102198.0851	102730.4186	0	126219.8691	126283.5199	-5004
102730.4186	102880.163	-4004	126283.5199	126688.1222	0
102880.163	103593.7238	0	126688.1222	126770.8041	3000
103593.7238	104384.9191	-1804	126770.8041	127130.7538	0
104384.9191	104665.8808	0	127130.7538	127196.7229	-5004
104665.8808	104798.1826	5000	127196.7229	127650.9356	0
104798.1826	105894.978	0	127650.9356	127715.2515	5000
105894.978	107643.5008	1800	127715.2515	127738.0744	0
107643.5008	109599.1078	0	127738.0744	127800.1074	-5004
109599.1078	111312.7704	-2504	127800.1074	128206.0187	0
111312.7704	111449.464	0	128206.0187	128271.0538	-5004
111449.464	111566.7597	6000	128271.0538	128359.9184	0
111566.7597	111686.5599	0	128359.9184	128448.9663	3300
111686.5599	111803.8555	-6004	128448.9663	128474.6469	0
111803.8555	112038.7916	0	128474.6469	128538.3262	-5004
112038.7916	112203.2093	5000	128538.3262	130435.6413	0
112203.2093	112526.72	0	130435.6413	130533.7548	-3004
112526.72	112621.7468	-6004	130533.7548	130553.9761	0
112621.7468	112818.3574	0	130553.9761	130938.0807	600
112818.3574	112977.0839	-6004	130938.0807	130960.43	0
112977.0839	113359.3283	0	130960.43	131042.8251	-3004

Forward			Return		
Start Dist. [m]	End Dist. [m]	Curvature Radius [m]	Start Dist. [m]	End Dist. [m]	Curvature Radius [m]
113359.3283	113535.4179	6000	131042.8251	133595.276	0
113535.4179	113656.0628	0	133595.276	133756.7259	1200
113656.0628	113773.3584	-6004	133756.7259	133867.2234	0
113773.3584	113953.6422	0	133867.2234	134030.9769	-1204
113953.6422	114097.2407	5000	134030.9769	134251.1461	0
114097.2407	114326.851	0	134251.1461	134410.469	-1304
114326.851	114593.8813	2500	134410.469	134523.4019	0
114593.8813	116817.4408	0	134523.4019	134684.5769	1300
116817.4408	117103.1729	2500	134684.5769	135268.4131	0
117103.1729	118607.0321	0	135268.4131	135374.9479	2000
118607.0321	118999.9874	2200	135374.9479	135529.445	0
118999.9874	119495.6076	0	135529.445	135639.7798	-2004
119495.6076	119872.5006	-1804	135639.7798	135893.7463	0
119872.5006	121153.1246	0	135893.7463	136004.0811	-2004
121153.1246	121270.8761	5000	136004.0811	136152.8615	0
121270.8761	121359.4831	0	136152.8615	136308.8267	1500
121359.4831	121477.2347	-5004	136308.8267	136385.1959	0
121477.2347	128258.1609	0	136385.1959	136488.7748	-2504
128258.1609	129116.2819	-1804	136488.7748	137543.6408	0
129116.2819	130883.8973	0	137543.6408	137624.9028	4000
130883.8973	131703.9937	1100	137624.9028	138226.6193	0
131703.9937	131931.8839	0	138226.6193	138307.8813	-4004
131931.8839	132160.3342	5004	138307.8813	138750.9541	0
132160.3342	132276.1495	0	138750.9541	138906.3366	-1304
132276.1495	132417.0274	-5000	138906.3366	138946.1972	0
132417.0274	132551.6912	0	138946.1972	139108.9898	1100
132551.6912	132683.9231	-5000	139108.9898	139141.3797	0
132683.9231	133068.956	0	139141.3797	139272.5266	-1804
133068.956	133201.3276	5004	139272.5266	139294.4844	0
133201.3276	134191.9625	0	139294.4844	139417.9292	1800
134191.9625	134519.3907	1200	139417.9292	139659.5511	0
134519.3907	134631.0889	0	139659.5511	139856.2829	-604
134631.0889	134834.638	-1204	139856.2829	139886.7389	0
134834.638	135205.4249	0	139886.7389	140017.2372	1000
135205.4249	135430.2476	1700	140017.2372	140183.1154	0
135430.2476	136010.5948	0	140183.1154	140318.2237	1400
136010.5948	136254.2244	-354	140318.2237	140351.6726	0
136254.2244	136343.0607	0	140351.6726	140499.4737	-1404
136343.0607	136646.4037	350	140499.4737	140621.2029	0
136646.4037	137201.8958	0	140621.2029	140684.8353	5000

