



**General Bid Bulletin No.7**  
**26 January 2021**

**IFB NO. 20-031-6**

**SOUTH COMMUTER RAILWAY PROJECT**  
**FOR PACKAGES CP S-04, CP S-05, CP S-06, AND CP S-07;**  
**CONSTRUCTION OF CIVIL STRUCTURES: VIADUCTS, BRIDGES,**  
**NINE (9) STATIONS, AND DEPOT**

**TO ALL PROSPECTIVE BIDDERS:**

This General Bid Bulletin is issued to amend/clarify certain provisions in the Bidding Documents for the abovementioned project. Please refer to the attached Annexes of this General Bid Bulletin duly approved by the end-user and co-implementer for details:

1. **Annex "A"** – CP S04-07 Responses to Clarification Requests (Batch 1); and
2. **Annex "B"** – CP S04-07 Responses to Clarification Requests (Batch 2)
3. **Please follow the link for the CAD Files as requested :**  
<https://drive.google.com/drive/folders/1yaT-cNuU7vQ9qPnpL1J5tCooxBy93vY5>

For your information and guidance.

For the Bids and Awards Committee VI,

**(SGD)**  
**WEBSTER M. LAUREÑANA**  
*Chairperson*

**CP S04-07 Responses to Clarification Requests (Batch 1)**

Packages	Vol	Sec	Page No.	Clause No./Title	Reference Text (if necessary)	Clarification Request	Final Response
ALL	1	1 & 4	ITB 9 & BF 6	Bid Prices and Discounts & Appendix 1: Discount for Multiple Package Awards	ITB 14.6 ITB 14.4 ITB 12.1 Bidding Forms Appendix 1 Discounts for Multiple Package Awards	<p>ITB clause 14.6 states that bids are being invited for, individual contracts (packages). According to the ITB clause 14.4 &amp; 12.1, the Bidder shall quote any discounts and the methodology for their application in the Letter of Bid, and the forms (Letter of Bids &amp; Others) must be completed without any alterations to the text, and no substitutes shall be accepted. But, the table in the Bidding Forms "Appendix 1: Discounts for Multiple Package Awards" has only the potential combinations containing Package S-04 essentially. For example, the combinations of Package "S-05 &amp; S-06", "S-05, S-06 &amp; S-07" and "S-05 &amp; S-07" are not in the Form.</p> <p>Please clarify the followings. 1. whether the combinations without Package S-04 mentioned in the above are allowed or not; and 2. if the mentioned combinations are allowed, whether the bidder can add these combinations in the table of the Form (Appendix 1: Discounts for Multiple Package Awards), or the amended Form will be provided to the bidders.</p>	<i>As specified in BDS 35.4, the Bidder may bid a single package, or for any combination packages (S-04, S-05, S-06, S-07). Discounts for multiple contracts may be offered by Bidders per package and may differ for different packages and package combinations. Bidding Forms Appendix 1 of the Bidding Document only serves as a template for the Bidders.</i>
S-05	1	Section 4A Bidding Forms - Bill of Quantities (BoQ)	-	All BOQ	-	The provided BOQ native excel format is locked and uneditable. Kindly, provide the unlocked editable version of BOQ in excel native format for tender preparation.	<i>The provided BOQ in excel format is working as intended. Cells not meant to be changed are protected.</i>
S-05	2	-	-	Drawings	-	Kindly, provide CAD formats of all drawings for tender preparation.	<i>CAD format of drawings will be provided for reference only and will be issued under Addendum No. 1. PDF will govern.</i>
S-06	1	Section 4A Bidding Forms - Bill of Quantities (BoQ)	-	-	-	Provided BOQ Excel native format is locked. Kindly, provide unlocked editable BOQ in Excel format for tender preparation.	<i>The provided BOQ in excel format is working as intended. Cells not meant to be changed are protected.</i>
S-06	2	-	-	Drawings	-	Kindly provide CAD formats of all drawing files for tender preparation.	<i>CAD format of drawings will be provided for reference only and will be issued under Addendum No. 1. PDF will govern.</i>
S-05	-	-	-	-	-	<p>With regards to the project referenced above, we, Daelim Industrial Co., Ltd., hereby submit our request for clarification as attached. Both native excel format and PDF format of the request for clarification are attached as mentioned in ITB clause 7.1.</p> <p>1. Kindly, provide CAD formats of all drawings for tender preparation. 2. Provided BOQ Excel native format is locked. Kindly, provide unlocked editable excel BOQ sheet for tender preparation.</p>	<p><i>1. CAD format of drawings will be provided for reference only and will be issued under Addendum No. 1. PDF will govern.</i></p> <p><i>2. The provided BOQ in excel format is working as intended. Cells not meant to be changed are protected.</i></p>

**CP S04-07 Responses to Clarification Requests (Batch 1)**

Packages	Vol	Sec	Page No.	Clause No./Title	Reference Text (if necessary)	Clarification Request	Final Response
S-06	-	-	-	-	-	<p>With regards to the project referenced above, we, Daelim Industrial Co., Ltd., hereby submit our request for clarification as attached.</p> <p>Both native excel format and PDF format of the request for clarification are attached as mentioned in ITB clause 7.1.</p> <p>1. Kindly, provide CAD formats of all drawings for tender preparation.</p> <p>2. Provided BOQ Excel native format is locked. Kindly, provide unlocked editable excel BOQ sheet for tender preparation.</p>	<p><b>1. CAD format of drawings will be provided for reference only and will be issued under Addendum No. 1. PDF will govern.</b></p> <p><b>2. The provided BOQ in excel format is working as intended. Cells not meant to be changed are protected.</b></p>
S-07	-	-	-	Invitation for Bids	<p>6. Bid Documents The bidder must pay a non-refundable fee of Philippine Pesos Seventy Five Thousand (Php 75,000.00) for each set of Bidding Documents required. ... For the avoidance of doubt, the non-refundable fee of Php 75,000 must be paid by a Bidder before submitting its Bid, regardless of whether the Bidder obtains a hard copy of the Bidding Document or not.</p>	<p>Please clarify whether a bidder JV should purchase Bidding Document in the name of the JV or it is acceptable if one partner of the bidder JV purchase the Bidding Documents in its name.</p>	<p><b>The payment receipt for the purchase of the Bidding Documents can be named to any partner of the JV which is yet to be constituted.</b></p>
S-07	1	Section 1 Instruction to Bidders (ITB)	-	19.8, Bid Security/Bid Securing Declaration	<p>19.8 If the bid security is required as per ITB 19.1, the bid security of a Joint Venture shall be in the name of the Joint Venture that submits the Bid. If the Joint Venture has not been legally constituted at the time of bidding, the bid security shall be in the name of any or all of the Joint Venture partners. If the Bid-Securing Declaration is required as per ITB 19.1, the Bid-Securing Declaration of a Joint Venture shall be in the name of the Joint Venture that submits the Bid. If the Joint Venture has not been legally constituted at the time of bidding, the Bid-Securing Declaration shall be in the names of all future partners as named in the letter of intent mentioned in ITB 4.1.</p>	<p>Please clarify whether each partner of the Joint Venture which has not been legally constituted at the time of bidding can respectively submit a bank guarantee of amount in accordance with its share of the Joint Venture that results in the total amount of all partners' bank guarantees equivalent to US\$ 5,000,000 instead of submitting a single bid security of US\$ 5,000,000 in the name of all partners.</p>	<p><b>The Employer will accept one (1) Bid Security that complies with the requirements under ITB 19.8</b></p>

**CP S04-07 Responses to Clarification Requests (Batch 1)**

Packages	Vol	Sec	Page No.	Clause No./Title	Reference Text (if necessary)	Clarification Request	Final Response
S-07	1	Section 2 Bid Data Sheet (BDS)	-	6.5, After ITB 6.4 add the following as ITB 6.5:	<p>“Site Data”. The Site Data may be downloaded from <a href="https://bit.ly/34zn958">https://bit.ly/34zn958</a>, the PS-DBM, DOTr and PNR websites listed in ITB 7.1 :</p> <ul style="list-style-type: none"> <li><input type="checkbox"/> Geotechnical Investigation Report</li> <li><input type="checkbox"/> Topographic Survey Drawings</li> <li><input type="checkbox"/> Utilities Database &amp; drawings</li> <li><input type="checkbox"/> Hydrology Report</li> <li><input type="checkbox"/> Hydrology Report – Areas with Insufficient Capacity (Package Specific)</li> <li><input type="checkbox"/> Marikina Fault Seismic Report</li> <li><input type="checkbox"/> Laguna Lake Development Report</li> <li><input type="checkbox"/> Resettlement Action Plan</li> <li><input type="checkbox"/> Schedule of Demolitions Due to RAP (Package Specific)</li> <li><input type="checkbox"/> Environmental Impact Statement (EIS)</li> <li><input type="checkbox"/> SCRП Tree Survey – Report</li> <li><input type="checkbox"/> Tree Cutting / Relocation from PNR / Private Land</li> <li><input type="checkbox"/> PNR Documents</li> <li><input type="checkbox"/> Historical Structures of Importance</li> <li><input type="checkbox"/> DPWH Structures Interface – (Particularly for S-02)</li> <li><input type="checkbox"/> Traffic Assessment Survey Report</li> </ul>	<p>Those documents are missing from site data :1-Hydrology Report -Areas with insufficient capacity ,Schedule of Demolitions Due to RAP, SCRП Tree survey report ,Tree cutting /relocation from PNR /private Land , DPWH Structures Interface ,Available Land</p>	<p><i>Information wil be provided as soon as it is available.</i></p>

**CP S04-07 Responses to Clarification Requests (Batch 1)**

Packages	Vol	Sec	Page No.	Clause No./Title	Reference Text (if necessary)	Clarification Request	Final Response
S-07	3	Section 7 General Conditions of Contract (GCC)	-	14.1, Contract Price	Particular Conditions: (a) the Contract Price shall be agreed or determined under Sub-Clause 12.3 [Evaluation ] and be subject to adjustments in accordance with the Contract; (b) the Contractor shall pay all taxes, duties and fees required to be paid by him under the Contract, and the Contract Price shall not be adjusted for any of these costs except as stated in Sub-Clause 13.7 [Adjustments for Changes in Legislation]; (c) any quantities which may be set out in the Bill of Quantities or other Schedule are estimated quantities and are not to be taken as the actual and correct quantities: (i) of the Works which the Contractor is required to execute, or (ii) for the purposes of Clause 12 [Measurement and Evaluation]; and (d) the Contractor shall submit to the Engineer, within 28 days after the Commencement Date, a proposed breakdown of each lump sum price in the Schedules. The Engineer may take account of the breakdown when	Please clarify what the contract currency is. (Ex. Philippine Peso (PHP) 100% or another foreign currency etc.)	<i>As stated in BDS 15.1, the unit rates and the prices shall be quoted by the Bidder in the Price Schedule separately in the following currencies: (i) For those inputs to the Works that the Bidder expects to supply from within the Employer's country, in Philippine Peso (PHP) (ii) For those input to the Works that the Bidder expects to supply from the outside the Employer's country in up to any three (3) foreign currencies</i>
S-07	2	Section 6 The Employer's Requirements (ERQ)		103.1, GS 103.1 Possession of Site and Access	There are many utilities which cross / run along the PNR Right of Way. Every effort will be made prior to award of Contract to divert / relocate these to assist in providing Free and Clear land. Information about these utilities is provided in Volume 2 Supplementary Information and Site Data, which shows the situation as at March 2020. In the event that the Employer has not arranged for the diversion / rerouting of utilities prior to Award of Contract, the Contractor shall be consulted regarding the time and cost implications of managing the diversion / relocation of these utilities by location prior to commencing the Works for that location.	Can we be updated about said utilities (their status and impacts to the project)?	<i>Information wil be provided as soon as it is available.</i>

**CP S04-07 Responses to Clarification Requests (Batch 1)**

Packages	Vol	Sec	Page No.	Clause No./Title	Reference Text (if necessary)	Clarification Request	Final Response
S-07	2	Section 6 The Employer's Requirements (ERQ)	-	02 Book 1 Civil	All drawings are issued as the version of pdf.	We kindly request of AUTOCAD version of all drawings.	<i>CAD format of drawings will be provided for reference only and will be issued under Addendum No. 1. PDF will govern.</i>
ALL	2	-	-	Drawings	-	We request for the AUTOCAD files of drawings provided	<i>CAD format of drawings will be provided for reference only and will be issued under Addendum No. 1. PDF will govern.</i>
ALL	1	Section 2 Bid Data Sheet (BDS)	-	6.5 / Missing Site Data Documents	<p>Alter ITB 6.4 add the following as ITB 6.5: The following documents constitute "Site Data". The Site Data may be downloaded from , <a href="https://bit.ly/34zn958">https://bit.ly/34zn958</a>, the PS-DBM, DOTr and PNR websites listed in ITB 7.1</p> <ul style="list-style-type: none"> <li><input type="checkbox"/> Geotechnical Investigation Report</li> <li><input type="checkbox"/> Topographic Survey Drawings</li> <li><input type="checkbox"/> Utilities Database &amp; drawings</li> <li><input type="checkbox"/> Hydrology Report</li> </ul> <p>- Areas with Insufficient Capacity (Package Specific)</p> <ul style="list-style-type: none"> <li><input type="checkbox"/> Marikina Fault Seismic Report</li> <li><input type="checkbox"/> Laguna Lake Development Report</li> <li><input type="checkbox"/> Resettlement Action Plan</li> <li><input type="checkbox"/> Schedule of Demolitions Due to RAP (Package Specific)</li> <li><input type="checkbox"/> Environmental Impact Statement (EIS)</li> <li><input type="checkbox"/> SCRP Tree Survey – Report</li> <li><input type="checkbox"/> Tree Cutting / Relocation from PNR / Private Land</li> <li><input type="checkbox"/> PNR Documents</li> <li><input type="checkbox"/> Historical Structures of Importance</li> <li><input type="checkbox"/> DPWH Structures Interface</li> </ul>	<p>"Please provide or clarify the following missing documents in the Site Data Folder link provided:</p> <ul style="list-style-type: none"> <li>- Hydrology Report- Areas with Insufficient Capacity (Package Specific)</li> <li>- Schedule of Demolitions due to RAP (Package specific)</li> <li>- SCRP Tree Survey-Report</li> <li>- Tree Cutting/Relocation from PNR/Private Land</li> <li>- DPWH Structures Interface</li> <li>- Available Land (Currently None)- Mapping (Package Specific)"</li> </ul>	<i>Information will be provided as soon as it is available.</i>

**CP S04-07 Responses to Clarification Requests (Batch 1)**

Packages	Vol	Sec	Page No.	Clause No./Title	Reference Text (if necessary)	Clarification Request	Final Response
ALL	1	Section 4 Bidding Form (BF)	-	52 / Audited FS	<p>"Attached are copies of financial statements (balance sheets including all related notes, and income statements) for the last five (5) years, as indicated above, complying with the following conditions</p> <p>-Unless otherwise required by Section 3 (Qualification Criteria), all such documents must reflect the financial situation of the legal entity or entities comprising the Applicant and not the Applicant's parent companies, subsidiaries, or affiliates.</p> <p>-Historical financial statements must be audited by a certified accountant.  <input type="checkbox"/> Historical financial statements must be complete, including all notes to the financial statements.</p> <p>-Historical financial statements must correspond to accounting periods already completed and audited (no statements for partial periods shall be requested or accepted)."</p>	Form FIN-1: Historical Financial Performance sheet requires us to submit the Audited Financial Statements for each of joint venture partner in case of a JV. We understand that we are required to submit the AFS of both the home office and branch office. Please clarify	<i>The AFS shall reflect the financial situation of the entity used for the Bid. If the branch office and the home office is considered as a single entity, then the Bidder needs to submit AFS including both.</i>
ALL	1	Section 2 Bid Data Sheet (BDS)	-	6.5 / Native files for the Topographic Survey	-	Topographic Survey Data was provided as part of the site data folder. We request for native files (TIN surface) of the topographic survey.	<i>Native files of the Topographic Survey will not be provided.</i>
S-06	1	Section 4 Bidding Form (BF)	-	Engineer's Concept Program	-	Please provide the planned start date.	<i>Planned Start date for S-06 is 4th Quarter 2021</i>
S-07	1	Section 4 Bidding Form (BF)	-	-	-	Please provide the planned start date.	<i>Planned Start date for S-07 is 4th Quarter 2021</i>

**CP S04-07 Responses to Clarification Requests (Batch 1)**

Packages	Vol	Sec	Page No.	Clause No./Title	Reference Text (if necessary)	Clarification Request	Final Response
S-05	1	Section 2 Bid Data Sheet (BDS)	BDS 4	19.1 / Bid Security	-	Please clarify that bidders shall furnish either 1 Bid Security as the name of JV with the amount of US\$ 11M or 2-3 Bid Securities separately based on share ratio of the JV members with the aggregate sum of US\$ 11M.	<i>The Employer will accept one (1) Bid Security that complies with the requirements under ITB 19.8</i>
S-05	1	3	EQC 16	Participation in multiple Packages	-	We are not clear of the Table shown in page no. EQC 16. For example, if we participate for 2 packages, i.e., Pkg. 4 & 5, suppose the requirements of Average Annual Construction Turnover are 45 for Pkg.4 and 55 for Pkg.5 respectively while our actual Average Annual Construction Turnover is 60. In this case, are we able to participate for both Pkg.4 & 5 simultaneously or should we participate for just one Pkg. because the minimum Average Annual Construction Turnover should be 100(45+55) for the participation of both packages?	<i>Yes, bidders can bid for more than one (1) package. However, Bidder shall pay attention to the following aggregated requirements as stated in Section 3 EQC 1.4.2 and EQC 1.4.3</i> <i>* Average annual construction turnover</i> <i>* Financial resources</i> <i>* Equipment to be allocated, and</i> <i>* Personnel to be fielded</i>
S-05	1	3	EQC 23&24	Construction Experience	-	Can we participate in multiple packages by using our only 1 similar work experience which meet the requirements of '2.4.1 Contracts of Similar Size and Nature' and '2.4.2 Construction Experience in Key Activities'?	<i>Yes.</i>
S-05	1	3	EQC 24	Viaduct works more than 4km	-	When we refer to the Invitation for Bids, the total length for the construction differ for Pkg.4, 5, and 6 with 8.5km, 12.8km, and 10.2km respectively. However, the length requirements for Viaduct works are all equally 4km. We would like to kindly request to adjust the requirements proportionate to the length of actual construction as follows: the length requirement for Pkg.5 (the longest one) - 4km, Pkg.6 - 3km, Pkg.4 - 2km.	<i>Pursuant to Section 3- EQC of the Bidding Document, Bidders are required to fulfil the requirement to have experience in the construction of viaducts of a minimum of 4km length. No adjustment to this requirement will be made.</i>
S-05	-	-	-	General Bid Bulletin No.1	-	Please let us know the exact procedure after we submit the request letter. For example, DOTr sends the official letter of cooperation to DFA and DFA issues the confirmation letter? In this case, should we visit the Embassy of the Philippines in our country and request for the visa issuance with that confirmation letter or DFA of the Philippines directly issue the visa?	<i>The visa assistance initiative by DOTr-PNR only aims to fast track a potential bidder's personnel's visa application. DOTr-PNR does not guarantee issuance of visa as this depends on DFA and the applicant. Follow ups may be done through the BAC Secretariat only.</i>
S-05	-	-	-	General Bid Bulletin No.1	-	Are prospective bidders 100% guaranteed for the entry to the Philippines if they submit their request letter to the BAC Secretariat, or will DOTr just attempt to make them available for the entry permit while not 100% guaranteed?	<i>The visa assistance initiative by DOTr-PNR only aims to fast track a potential bidder's personnel's visa application. DOTr-PNR does not guarantee issuance of visa as this depends on DFA and the applicant. Follow ups may be done through the BAC Secretariat only.</i>



**CP S04-07 Responses to Clarification Requests (Batch 1)**

Packages	Vol	Sec	Page No.	Clause No./Title	Reference Text (if necessary)	Clarification Request	Final Response
S-04	1	-	BDS 1&BDS 2	After ITB 6.4 add the following as ITB 6.5:	<p>The following documents constitute "Site Data". The Site Data may be downloaded from <a href="https://bit.ly/34zn958">https://bit.ly/34zn958</a>, the PS-DBM, DOTr and PNR websites listed in ITB 7.1 :</p> <ul style="list-style-type: none"> <li><input type="checkbox"/> Geotechnical Investigation Report</li> <li><input type="checkbox"/> Topographic Survey Drawings</li> <li><input type="checkbox"/> Utilities Database &amp; drawings</li> <li><input type="checkbox"/> Hydrology Report</li> <li><input type="checkbox"/> Hydrology Report – Areas with Insufficient Capacity (Package Specific)</li> <li><input type="checkbox"/> Marikina Fault Seismic Report</li> <li><input type="checkbox"/> Laguna Lake Development Report</li> <li><input type="checkbox"/> Resettlement Action Plan</li> <li><input type="checkbox"/> Schedule of Demolitions Due to RAP (Package Specific)</li> <li><input type="checkbox"/> Environmental Impact Statement (EIS)</li> <li><input type="checkbox"/> SCRП Tree Survey – Report</li> <li><input type="checkbox"/> Tree Cutting / Relocation from PNR / Private Land</li> <li><input type="checkbox"/> PNR Documents</li> <li><input type="checkbox"/> Historical Structures of Importance</li> <li><input type="checkbox"/> DPWH Structures Interface – (Particularly for S-02)</li> <li><input type="checkbox"/> Traffic Assessment Survey Report</li> </ul>	<p>Those documents are missing from site data :1-Hydrology Report - Areas with insufficient capacity ,Schedule of Demolitions Due to RAP,SCRП Tree survey report ,Tree cutting /relocation from PNR /private Land ,DPWH Structures Interface ,Available Land</p>	<p><i>Information will be provided as soon as it is available.</i></p>
S-04	-	Invitation for Bids	2	6. Bid Documents	<p>The bidder must pay a non-refundable fee of Philippine Pesos Seventy Five Thousand (Php 75,000.00) for each set of Bidding Documents required.</p> <p>...</p> <p>For the avoidance of doubt, the non-refundable fee of Php 75,000 must be paid by a Bidder before submitting its Bid, regardless of whether the Bidder obtains a hard copy of the Bidding Document or not.</p>	<p>Please clarify whether a bidder JV should purchase Bidding Document in the name of the JV or it is acceptable if one partner of the bidder JV purchase the Bidding Documents in its name.</p>	<p><i>The payment receipt for the purchase of the Bidding Documents can be named to any partner of the JV which is yet to be constituted.</i></p>

**CP S04-07 Responses to Clarification Requests (Batch 1)**

Packages	Vol	Sec	Page No.	Clause No./Title	Reference Text (if necessary)	Clarification Request	Final Response
S-04	1	Section 1 Instruction to Bidders	ITB 13	19. Bid Security/Bid Securing Declaration	19.8 If the bid security is required as per ITB 19.1, the bid security of a Joint Venture shall be in the name of the Joint Venture that submits the Bid. If the Joint Venture has not been legally constituted at the time of bidding, the bid security shall be in the name of any or all of the Joint Venture partners. If the Bid-Securing Declaration is required as per ITB 19.1, the Bid-Securing Declaration of a Joint Venture shall be in the name of the Joint Venture that submits the Bid. If the Joint Venture has not been legally constituted at the time of bidding, the Bid-Securing Declaration shall be in the names of all future partners as named in the letter of intent mentioned in ITB 4.1.	Please clarify whether each partner of the Joint Venture which has not been legally constituted at the time of bidding can respectively submit a bank guarantee of amount in accordance with its share of the Joint Venture that results in the total amount of all partners' bank guarantees equivalent to US\$ 7,000,000 instead of submitting a single bid security of US\$ 7,000,000 in the name of all partners.	<i>The Employer will accept one (1) Bid Security that complies with the requirements under ITB 19.8</i>
S-04	2&3	-	GS3	GS 103 1 Possession of Site and Access	There are many utilities which cross / run along the PNR Right of Way. Every effort will be made prior to award of Contract to divert / relocate these to assist in providing Free and Clear land. Information about these utilities is provided in Volume 2 Supplementary Information and Site Data, which shows the situation as at March 2020. In the event that the Employer has not arranged for the diversion / rerouting of utilities prior to Award of Contract, the Contractor shall be consulted regarding the time and cost implications of managing the diversion / relocation of these utilities by location prior to commencing the Works for that location.	Can we be updated about said utilities (their status and impacts to the project)?	<i>Information will be provided as soon as it is available.</i>

**CP S04-07 Responses to Clarification Requests (Batch 1)**

Packages	Vol	Sec	Page No.	Clause No./Title	Reference Text (if necessary)	Clarification Request	Final Response
S-04	2&3	-	GS3	GS 103 1 Possession of Site and Access	Such possession and access shall be made available to the Contractor on the date for Commencement of Works as established under GCC Clause 8.1. Where site possession is not available across the whole of the works, the Employer may give possession on a staged basis where portions are available. Full site possession will be given not later than 12 months after the initial staged possession has commenced. The Contractor shall revise the Detailed Works Program to reflect the staging of works to align with the available possession at no additional cos	Considering stage based programme and ROW which is under control of PNR ,Time for the completion of the works (1460 days ) is not enough to construct this project .Required project duration based on our experience for this project is to be 1800 days ,kindly confirm?	<i>Bidders are advised that the project duration will remain unchanged and the bidder should compile its bid accordingly.</i>
S-04	3	-	1	Section 7	As per GCC, FIDIC (FIDIC MDB Harmonized Construction Contract) dated June 2010 are applicable for this project. According to FIDIC, Clause 14, after Contractor submit interim payment certificate to Engineer. Engineer has 28 days for review period. Afterwards, Employer has made payment within 56 days. To conclude, after submission of IPC by Contractor, the total payment duration is approximately is 3 months.	We kindly request to shorten this period to obtain a positive Income/Expenditure balance.	<i>Bidders are advised that payment periods will remain unchanged.</i>
S-04	2	-	-	02 Book 1 Civil	All drawings are issued as the version of pdf.	We kindly request of AUTOCAD version of all drawings.	<i>CAD format of drawings will be provided for reference only and will be issued under Addendum No. 1. PDF will govern.</i>
S-04	2	Section 6, IA-SOW	14	2.5	Scope of work related with the land of casting yard	We would like to request that the Employer may provide the temporary land (aproximately 50 hectares) for casting yard.	<i>As stated in GS 104, Bidders are advised that the Contractor shall be responsible for sourcing and procuring all land necessary for the provision of various temporary facilities that will be required throughout the duration of the Project.</i>
S-04	2	Section 6, IA-SOW	14	2.5	Scope of work related with the land of casting yard	We would like to request that the Employer may provide the temporary land (aproximately 20 hectares) for employer and contractor main offices.	<i>As stated in GS 104, Bidders are advised that the Contractor shall be responsible for sourcing and procuring all land necessary for the provision of various temporary facilities that will be required throughout the duration of the Project.</i>

**CP S04-07 Responses to Clarification Requests (Batch 1)**

Packages	Vol	Sec	Page No.	Clause No./Title	Reference Text (if necessary)	Clarification Request	Final Response
S-04	1	Bidding Forms	BF11	Table of Adjustment Data	The weightings (coefficient B, C and D) for each of factors of cost shall be proposed by a Bidder in column (e). The Contractor shall enter Base Value and Date in column (d).	Please clarify Contractor or Employer will shall enter base value and date in column (d)	<p><i>For Local Currency Payment, the Employer shall enter the Base Value and Date.</i></p> <p><i>For Foreign Currency Payment, the Bidder shall proposed from index published by the Governmental office or institution or agent authorized by the Government office in the country of correspondiing currency, hence, the Bidder shall input the Base Value and Date.</i></p> <p><i>Note that as per GCC 1.1.3.1, "Base Date" means the 28 days prior to the latest date for submission of the bid.</i></p>
S-05	1	Section 1 Instruction to Bidders (ITB)	-	14.6 / Bid Prices and Discounts & Appendix 1: Discounts for Multiple Package Awards	ITB 14.6 ITB 14.4 ITB 12.1 Bidding Forms Appendix 1: Discounts for Multiple Package Awards	<p>ITB clause 14.6 states that bids are being invited for individual contracts or for any combination of contracts (packages). According to the ITB clause 14.4 &amp; 12.1, the Bidder shall quote any discounts and the methodology for their application in the Letter of Bid, and the forms (Letter of Bid &amp; Others) must be completed without any alterations to the text, and no substitutes shall be accepted.</p> <p>But, the table in the Bidding Forms "Appendix 1: Discounts for Multiple Package Awards" has only the potential combinations containing Package S-04 essentially. For example, the combinations of Package "S-05 &amp; S-06", "S-05, S-06 &amp; S-07" and "S-05 &amp; S-07" are not in the Form.</p> <p>Please clarify the followings.</p> <ol style="list-style-type: none"> <li>whether the combinations without Package S-04 mentioned in the above are allowed or not; and</li> <li>if the mentioned combinations are allowed, whether the bidder can add these combinations in the table of the Form (Appendix 1: Discounts for Multiple Package Awards), or the amended Form will be provided to the bidders.</li> </ol>	<p><i>As specified in BDS 35.4, the Bidder may bid a single package, or for any combination packages (S-04, S-05, S-06, S-07). Discounts for multiple contracts may be offered by Bidders per package and may differ for different packages and package combinations. Please see revised form to be issued in Addendum 1.</i></p>

**CP S04-07 Responses to Clarification Requests (Batch 2)**

Packages	Vol	Sec	Page No.	Clause No./Title	Reference Text (if necessary)	Clarification Request	Final Response
S-04	1	Section 2 BDS	BDS 4	ITB 15.1, 15.4	Currencies of Bid	Please clarify that there is no currency specified in the BDS. Is it possible that bidder can use any currencies among the ITB Part1, Section5 corresponding countries?(Eligible Countries) or only can use which presented in the Bill of Quantities(Section4) “12. Abbreviation Used in the Bills of Quantities”[PHP, GBP, JPY, EUR, USD]	<i>Refer to BDS 15.1 (ii) For those inputs to the Works that the Bidder expects to supply from outside the Employer’s country (referred to as “the foreign currency requirements”) in up to any three (3) foreign currencies.</i>
S-05	3	Section 8 PCC	PCC-10	Part B – Specific Provision	“ad measurement” means focused measurement on change to limited items to show the increase or decrease in an item or limited series of items so that the cost saving or cost increase can be ascertained and reported. It excludes comprehensive remeasurement	We kindly request of the definition of an admeasurement contract and clear difference with remeasurement. In the GCC,” The conditions of Contract have been prepared for an ad measurement (unit price or unit rate) type of contract and cannot be used for other types of contract”	<i>Bidder is advised as follows; Clarification for Section 8 PCC page PCC-10 Part B - Specific Provision: The Works design is Detailed Design and the Bills of Quantities have been measured to reflect the Detailed Design. This means that with limited exclusions there will be no reason to remeasure the Works. Ad measurement is the measurement of change from the Detailed Design to the revised designs as instructed. This will not require wholesale remeasurement.</i>
S-05	1	Section 2 BDS	BDS 4	ITB 15.1, 15.4	Currencies of Bid	Please clarify that there is no currency specified in the BDS. Is it possible that bidder can use any currencies among the ITB Part1, Section5 corresponding countries?(Eligible Countries) or only can use which presented in the Bill of Quantities(Section4) “12. Abbreviation Used in the Bills of Quantities”[PHP, GBP, JPY, EUR, USD]	<i>Refer to BDS 15.1 (ii) For those inputs to the Works that the Bidder expects to supply from outside the Employer’s country (referred to as “the foreign currency requirements”) in up to any three (3) foreign currencies.</i>
S-06	3	Section 8 PCC	PCC-10	Part B – Specific Provision	“ad measurement” means focused measurement on change to limited items to show the increase or decrease in an item or limited series of items so that the cost saving or cost increase can be ascertained and reported. It excludes comprehensive remeasurement	We kindly request of the definition of an admeasurement contract and clear difference with remeasurement. In the GCC,” The conditions of Contract have been prepared for an ad measurement (unit price or unit rate) type of contract and cannot be used for other types of contract”	<i>Bidder is advised as follows; Clarification for Section 8 PCC page PCC-10 Part B - Specific Provision: The Works design is Detailed Design and the Bills of Quantities have been measured to reflect the Detailed Design. This means that with limited exclusions there will be no reason to remeasure the Works. Ad measurement is the measurement of change from the Detailed Design to the revised designs as instructed. This will not require wholesale remeasurement.</i>
S-06	1	Section 2 BDS	BDS 4	ITB 15.1, 15.4	Currencies of Bid	Please clarify that there is no currency specified in the BDS. Is it possible that bidder can use any currencies among the ITB Part1, Section5 corresponding countries?(Eligible Countries) or only can use which presented in the Bill of Quantities(Section4) “12. Abbreviation Used in the Bills of Quantities”[PHP, GBP, JPY, EUR, USD]	<i>Refer to BDS 15.1 (ii) For those inputs to the Works that the Bidder expects to supply from outside the Employer’s country (referred to as “the foreign currency requirements”) in up to any three (3) foreign currencies.</i>

**CP S04-07 Responses to Clarification Requests (Batch 2)**

Packages	Vol	Sec	Page No.	Clause No./Title	Reference Text (if necessary)	Clarification Request	Final Response
S-04	-	Reff: EQC Item 2.4.2	-	Experiences	One project of minimum of 4 km using precast segmental span bu span technique, including bored or precast piling and reinforced concrete pile caps and piers	Based on our experiences, Waskita Karya already build LRT Palembang with Precast I Girder, can we use it as our experiences?	<i>No.</i>
S-07	-	-	-			Is it allowed for a contractor to submit the offer to two packages (ex: Packages number 5 and Packages number 7) using the same list of personnel? If yes, what will happen when the contractor wins the two packages? If no, is there any regulation or local laws that prohibit this case?	<p><i>Bidders shall pay attention to the following aggregated requirements as stated under EQC 1.4.2 - 1.4.3:</i></p> <ul style="list-style-type: none"> <li><i>* Average annual construction turnover</i></li> <li><i>* Financial resources</i></li> <li><i>* Equipment to be allocated, and</i></li> <li><i>* Personnel to be fielded</i></li> </ul> <p><i>Where personnel can be reasonably shared between individual contracts, the Bidder shall demonstrate in detail the contracts can be implemented simultaneously and on time. The acceptance of proposed shared personnel is subject to full discretion of the Employer.</i></p>

**CP S04-07 Responses to Clarification Requests (Batch 2)**

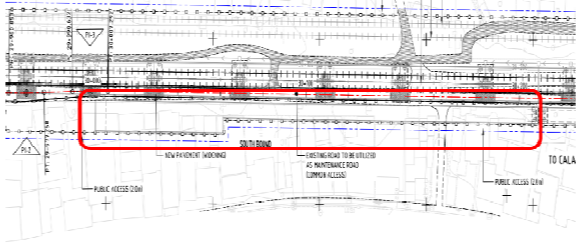
Packages	Vol	Sec	Page No.	Clause No./Title	Reference Text (if necessary)	Clarification Request	Final Response												
S-04	2	General				Please provide the applied design soil properties for Temporary works design.	<i>Bidder is responsible for design of all temporary facility work. A geotechnical investigation report is provided under Site Data.</i>												
S-04	1	Sec.4A BOQ				According to BOQ, GI(geotechnical investigation) length is 6,343m. Please also provide total borehole number for GI.	<i>Bidders are advised that the total number of boreholes will be determined by the actual ground conditions and shall be assessed by the bidder from geotechnical information provided</i>												
S-04	2	Section 6 IB appendix 12-2	Page 3	B. During deployment		This order which is No.39 mentioned 'quarter' for work's safety during deployment. Please clarify that the meaning of the 'quarter'. (ie. Quarter means construction site or accommodation in local area)	<i>Bidder is advised that "Quarter" means accommodation on the site for people employed on the project. It excludes accommodation in the local area as Order No. 39 requires people going off site to follow the protocols for "Prior to Deployment" on return to site as described in paragraphs 2 and 3.</i>												
S-04	2	Section 6 TS	TS-200-52	204.2.6.2 204.2.6.3 206.18.3.2 217.2.2		Please provide the detail information of 'Licensed professional engineer' and 'Registered professional engineer'	<i>Bidder is advised to follow Philippine Engineer Licensing practice in relation to this requirement.</i>												
S-04	1	Sec.4A BOQ		General	Reinforcement Steel (Lap Splicing)	1) Please clarify that the lap splicing quantities are included in reinforcement steel of BOQ or not. 2) Please clarify that the lap splicing quantities will be paid by Employer or not.	<i>1) Bidder is advised that the quantities of lap splicing shown in the drawings are included in reinforcement steel of BOQ. 2) Bidder is advised that the quantities of lap splicing stated in the drawings issued for contract will be paid by the Employer.</i>												
S-04	2	Section 6 II Drawings		NSRP-DWG-VIA04-RD-3033, NSRP-DWG-VIA04-ST-0035 to 0036		 <p>As per drawing, NSRP-DWG-VIA04-ST-0035 to 0036, maintenance ramp &amp; bridge is linked to main line track.</p> <p>Please clarify maintenance ramp &amp; standing area is also under contractor's responsibility in addition to bridge section.</p> <p>If yes, please provide details and section drawing of maintenance ramp and standing area for bidder's pricing.</p>	<p><i>Bidders are advised that the Maintenance ramp will be contractor's responsibility. Please refer to CIS70. BoQ item is already included.</i></p> <table border="1"> <thead> <tr> <th colspan="2">PART B.11</th> <th colspan="2">STRUCTURAL WORKS FOR MAINTENANCE RAMP AND EMERGENCY</th> </tr> </thead> <tbody> <tr> <td>206</td> <td>206(7)c</td> <td>Structural Cast in situ Concrete, 40 MPa for Maintenance Ramp Approach Structures</td> <td>cum</td> </tr> <tr> <td>207</td> <td>207(2)t</td> <td>Reinforcing Steel, Grade 60 for Maintenance Ramp Approach Structure</td> <td>kg</td> </tr> </tbody> </table>	PART B.11		STRUCTURAL WORKS FOR MAINTENANCE RAMP AND EMERGENCY		206	206(7)c	Structural Cast in situ Concrete, 40 MPa for Maintenance Ramp Approach Structures	cum	207	207(2)t	Reinforcing Steel, Grade 60 for Maintenance Ramp Approach Structure	kg
PART B.11		STRUCTURAL WORKS FOR MAINTENANCE RAMP AND EMERGENCY																	
206	206(7)c	Structural Cast in situ Concrete, 40 MPa for Maintenance Ramp Approach Structures	cum																
207	207(2)t	Reinforcing Steel, Grade 60 for Maintenance Ramp Approach Structure	kg																

**CP S04-07 Responses to Clarification Requests (Batch 2)**

Packages	Vol	Sec	Page No.	Clause No./Title	Reference Text (if necessary)	Clarification Request	Final Response
S-04	3	Section 8 PCC	PCC-10	Part B – Specific Provision	“ad measurement” means focused measurement on change to limited items to show the increase or decrease in an item or limited series of items so that the cost saving or cost increase can be ascertained and reported. <b>It excludes comprehensive remeasurement</b>	We kindly request of the definition of an admeasurement contract and clear difference with remeasurement. In the GCC,” The conditions of Contract have been prepared for an ad measurement (unit price or unit rate) type of contract and cannot be used for other types of contract”	<i>Bidder is advised as follows; Clarification for Section 8 PCC page PCC-10 Part B - Specific Provision: The Works design is Detailed Design and the Bills of Quantities have been measured to reflect the Detailed Design. This means that with limited exclusions there will be no reason to remeasure the Works. Ad measurement is the measurement of change from the Detailed Design to the revised designs as instructed. This will not require wholesale remeasurement.</i>
S-04	2	Sec.6	GS8	104.1.4 Medical Facilities	It/they shall be provided with an ambulance(s) with full-time drivers as detailed in Appendix 5 hereto.	According to Appendix 5, Please provide us related requirements regarding ambulance(s).	<i>Bidder is advised as follows; Clarification for Section 6 GS8, 104.1.4 Medical Facilities, requirements for ambulances: The Bidder shall assess the requirements for the Project Package considering location, length of project Right of Way, proposed locations for Offices, accommodation and welfare facilities, fabrication facilities and the number of workers to be employed for the Works, local off-site medical facilities, training of staff and supervision, and then assess what facilities will be required including medical staff and facilities on site including emergency vehicles such as ambulances. The Bidder shall be responsible for assessing the logistics requirements, price accordingly and if successful, implement its proposals. Facilities located off-site may be used provided satisfactory terms are established for health protocols, response times and the provision of vehicles suitable for accessing all locations on site in all weather and conditions, be available 24 hours a day 7 days a week.</i>
S-04	2	Sec.6 Volume 1A Sec.4A BOQ	GS35	113.2 Measurement and Payment	Lump Sum Fixed charges will be once only payments for mobilization and demobilization. Lump Sum Time related charges will be spread over the Contract Period.	There are discrepancy between BOQ and GS 113.2. Please clarify that Utility treatment work is Provisional sum or Lump sum?	<i>Bidder is referred to Item GS113 of Bill No.1. Utility treatment work &amp; Utilities Relocation and Protection should be paid in Provisional sum.</i>



**CP S04-07 Responses to Clarification Requests (Batch 2)**

Packages	Vol	Sec	Page No.	Clause No./Title	Reference Text (if necessary)	Clarification Request	Final Response
S-04	2	Sec.6	GS90	128.1 Defect Liability	The Warranty Period for contractual spare parts, special tools and testing equipment or any other item of equipment delivered shall be thirty six (36) months (1,095 calendar days) from the date of delivery and acceptance by the Employer of such spare parts, tools and test equipment or any other equipment.	Please clarify the specific quantity for each spare parts items.	<i>Bidders are advised to refer to refer to relevant General Specifications and Technical Specifications to determine spare parts requirements.</i>
S-04	2	Drawing		NSRP-DWG-VIA00-ST-1201	Temporary Prestress Bar	As per drawing, NSRP-DWG-VIA00-ST-1201, type of temporary prestress bar for PSM viaduct is 40Ø, 29Ø VSL CT Stress Bar.  Please clarify bidder can propose equivalent type of prestress bar or the Client has any design preference.	<i>Bidder can propose the prestressing type for use. The Contractor will have a responsibility of the equivalent type of the system. Please refer to "TS208.3".</i>
S-04	2	Drawing		NSRP-DWG-VIA00-ST-1121	Post-Tensioning	As per prestressing notes on drawing, NSRP-DWG-VIA00-ST-1121, it states that "The bridge superstructure has been detailed for the Freyssinet post-tensioning system".  Please clarify bidder can propose equivalent post-tensioning system or the Client has any design preference.	<i>Bidder can propose the post-tensioning system for use. The Contractor will have a responsibility of the equivalent type of the system.</i>
S-04	2	Section 6 II Drawing VIA00	27, 28		All Table	Please provide pile reinforcement type for all each piers to bidder.	<i>Bidder is referred to Pile schedule of VIA 04 Drawing sets.</i>

**CP S04-07 Responses to Clarification Requests (Batch 2)**

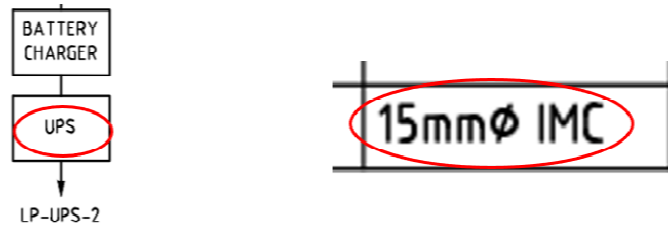
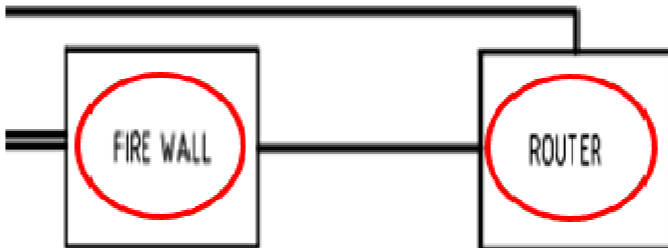
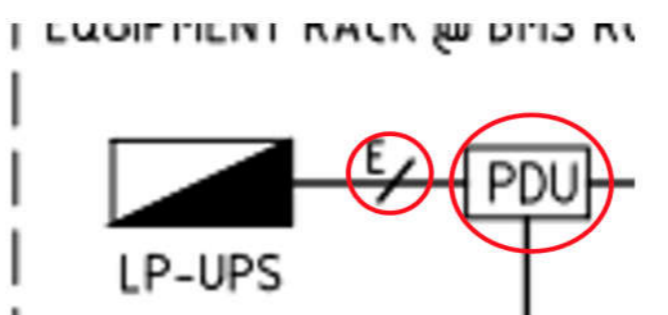
Packages	Vol	Sec	Page No.	Clause No./Title	Reference Text (if necessary)	Clarification Request	Final Response
S-04	2	02.Book2.04-S04 ELEC. CP S-04-03-ALA-EL	- NSRP-DWG-ALA -EL-5701	FIRE DETECTION AND ALARM SYSTEM SCHEMATIC DIAGRAM		 <p>We can't find out some items in the BOQ. But the items are in the relevant drawings. Please clarify that as following items;</p> <ul style="list-style-type: none"> <li>- UPS</li> <li>- 15 mm dia IMC Conduit</li> </ul>	<i>Bidder is advised that pay item for UPS is included in 706(11)am ALA - LP UPS incl 30kVA UPS. Quantity for 15mm dia IMC is already included in 707(4)i 20mm dia IMC as circuit LP-UPS/2.</i>
S-04	2	02.Book2.04-S04 ELEC. CP S-04-03-ALA-EL	- NSRP-DWG-ALA -EL-5803	CCTV SYSTEM DIAGRAM UNPAID AREA		 <p>We can't find out some items in the BOQ. But the items are in the relevant drawings. Please clarify that as following items;</p> <ul style="list-style-type: none"> <li>- FIRE WALL and ROUTER</li> </ul>	<i>Bidder is advised that cost for Fire wall &amp; router is included in pay item 715(1)e Server</i>
S-04	2	02.Book2.04-S04 ELEC. CP S-04-03-ALA-EL	- NSRP-DWG-ALA -EL-5825	ACCESS CONTROL SYSTEM SCHEMATIC DIAGRAM		 <p>We can't find out some items in the BOQ. But the items are in the relevant drawings. Please clarify that as following items;</p> <ul style="list-style-type: none"> <li>- PDU and cable E</li> </ul>	<i>Bidder is advised that cost for PDU &amp; cable E is included in pay item 715(2)b Access Control Panel</i>

**CP S04-07 Responses to Clarification Requests (Batch 2)**

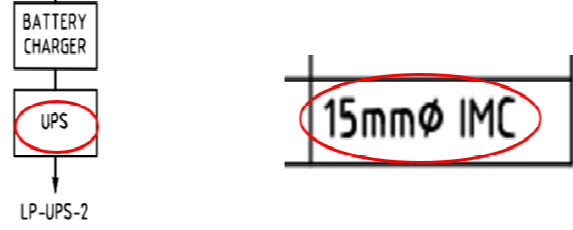
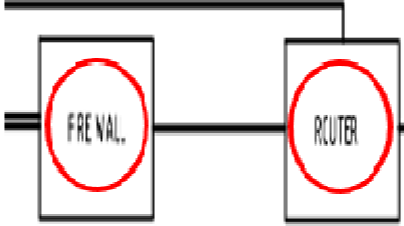
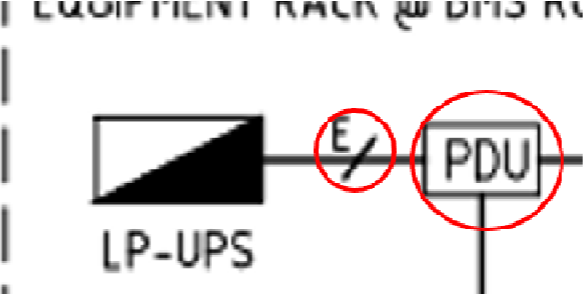
Packages	Vol	Sec	Page No.	Clause No./Title	Reference Text (if necessary)	Clarification Request	Final Response
S-04	2	02.Book2.04-S04 ELEC. CP S-04-03-MUN-EL	- NSRP-DWG-MUN - EL-5701	FIRE DETECTION AND ALARM SYSTEM SCHEMATIC DIAGRAM		 <p>We can't find out some items in the BOQ. But the items are in the relevant drawings. Please clarify that as following items;</p> <ul style="list-style-type: none"> <li>- UPS</li> <li>- 15 mm dia IMC Conduit</li> </ul>	<i>Bidder is advised that pay item for UPS is included in 706(12)ag MUN - LP UPS incl 30kVA UPS. Quantity for 15mm dia IMC is already included in 707(4)i 20mm dia IMC as circuit LP-UPS/2.</i>
S-04	2	02.Book2.04-S04 ELEC. CP S-04-03-MUN-EL	- NSRP-DWG-MUN - EL-5803	CCTV SYSTEM DIAGRAM UNPAID AREA		 <p>We can't find out some items in the BOQ. But the items are in the relevant drawings. Please clarify that as following items;</p> <ul style="list-style-type: none"> <li>- FIRE WALL and ROUTER</li> </ul>	<i>Bidder is advised that cost for Fire wall &amp; router is included in pay item 715(1)e Server</i>
S-04	2	02.Book2.04-S04 ELEC. CP S-04-03-MUN-EL	- NSRP-DWG-MUN-EL-5825	ACCESS CONTROL SYSTEM SCHEMATIC DIAGRAM		 <p>We can't find out some items in the BOQ. But the items are in the relevant drawings. Please clarify that as following items;</p> <ul style="list-style-type: none"> <li>- PDU and cable E</li> </ul>	<i>Bidder is referred to pay item 715(2)b Access Control Panel</i>

**CP S04-07 Responses to Clarification Requests (Batch 2)**

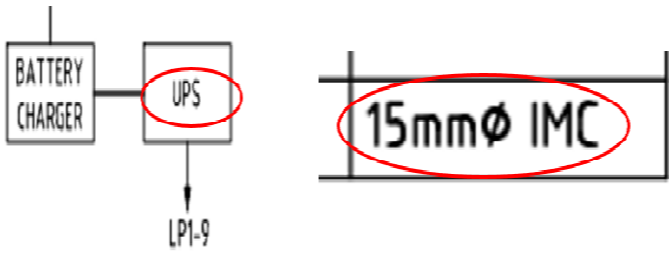
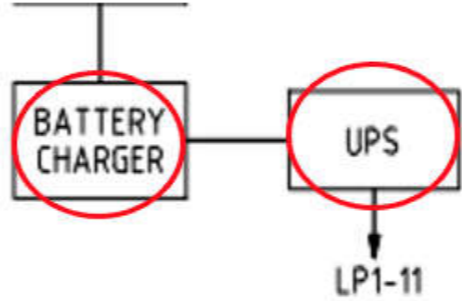
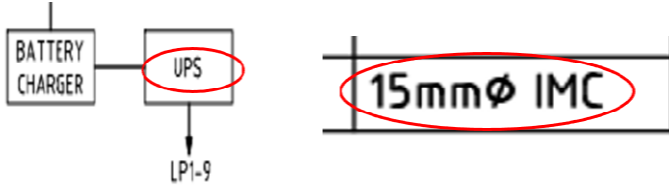
Packages	Vol	Sec	Page No.	Clause No./Title	Reference Text (if necessary)	Clarification Request	Final Response
S-04	2	02.Book2. 04-S04 ELEC. CPS-04-03- SS_Electrical_S S_07-09	- NSRP- DWG- SS7 -EL- 5701	FIRE DETECTION AND ALARM SYSTEM SCHEMATIC DIAGRAM		 <p>We can't find out some items in the BOQ. But the items are in the relevant drawings. Please clarify that as following items; - UPS - 15 mm dia IMC Conduit</p>	<i>Bidder is advised that cost for UPS is included in pay item 716(8)b Fire Alarm Control Panel for Substation. Quantity is included in pay item 707(4)i 20mm dia IMC as circuit LP1 -9</i>
S-04	2	02.Book2. 04-S04 ELEC. CPS-04-03- SS_Electrical_S S_07-09	- NSRP- DWG- SS7 -EL- 5801	ACCESS CONTROL SYSTEM SCHEMATIC DIAGRAM		 <p>We can't find out some items in the BOQ. But the items are in the relevant drawings. Please clarify that as following items; - UPS - Battery Charger</p>	<i>Bidder is advised that cost for UPS is included in pay item 715(2)b Access Control Panel &amp; cost for Battery Charger is included in pay item 715(2)i Battery</i>
S-04	2	02.Book2. 04-S04 ELEC. CPS-04-03- SS_Electrical_S S_07-09	- NSRP- DWG- SS8 -EL- 5701	FIRE DETECTION AND ALARM SYSTEM SCHEMATIC DIAGRAM		 <p>We can't find out some items in the BOQ. But the items are in the relevant drawings. Please clarify that as following items; - UPS - 15 mm dia IMC Conduit</p>	<i>Bidder is advised that cost for UPS is included in pay item 716(8)b Fire Alarm Control Panel for Substation. Quantity is included in pay item 707(4)i 20mm dia IMC as circuit LP1 -9</i>

**CP S04-07 Responses to Clarification Requests (Batch 2)**

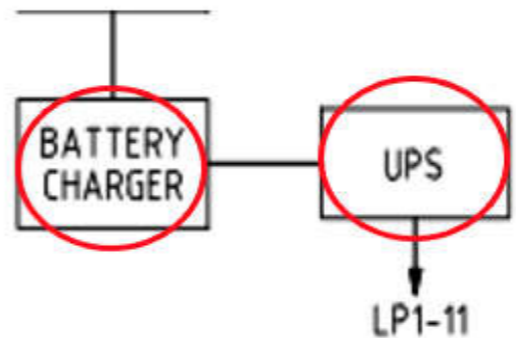
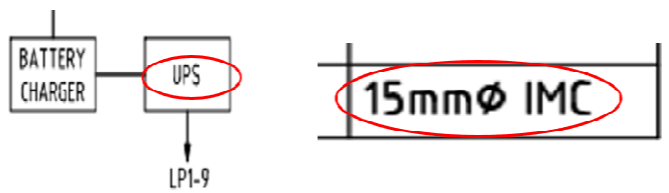
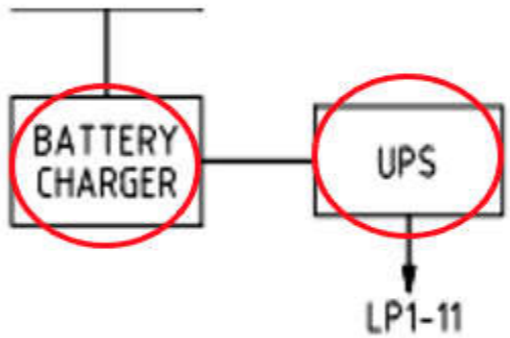
Packages	Vol	Sec	Page No.	Clause No./Title	Reference Text (if necessary)	Clarification Request	Final Response
S-04	2	02.Book2. 04-S04 ELEC. CPS-04-03- SS_Electrical_S S_07-09	- NSRP- DWG- SS8 -EL- 5801	ACCESS CONTROL SYSTEM SCHEMATIC DIAGRAM		 <p>We can't find out some items in the BOQ. But the items are in the relevant drawings. Please clarify that as following items; - UPS - Battery Charger</p>	<i>Bidder is advised that cost for UPS is included in pay item 715(2)b Access Control Panel &amp; cost for Battery Charger is included in pay item 715(2)i Battery</i>
S-04	2	02.Book2. 04-S04 ELEC. CPS-04-03- SS_Electrical_S S_07-09	- NSRP- DWG- SS9 -EL- 5701	FIRE DETECTION AND ALARM SYSTEM SCHEMATIC DIAGRAM		 <p>We can't find out some items in the BOQ. But the items are in the relevant drawings. Please clarify that as following items; - UPS - 15 mm dia IMC Conduit</p>	<i>Bidder is advised that cost for UPS is included in pay item 716(8)b Fire Alarm Control Panel for Substation. Quantity is included in pay item 707(4)i 20mm dia IMC as circuit LP1 -9</i>
S-04	2	02.Book2. 04-S04 ELEC. CPS-04-03- SS_Electrical_S S_07-09	- NSRP- DWG- SS9 -EL- 5801	ACCESS CONTROL SYSTEM SCHEMATIC DIAGRAM		 <p>We can't find out some items in the BOQ. But the items are in the relevant drawings. Please clarify that as following items; - UPS - Battery Charger</p>	<i>Bidder is advised that cost for UPS is included in pay item 715(2)b Access Control Panel &amp; cost for Battery Charger is included in pay item 715(2)i Battery</i>

**CP S04-07 Responses to Clarification Requests (Batch 2)**

Packages	Vol	Sec	Page No.	Clause No./Title	Reference Text (if necessary)	Clarification Request	Final Response
S-05	2	General				Please provide the applied design soil properties for Temporary works design.	<i>Bidder is responsible for design of all temporary facility work. A geotechnical investigation report is provided under Site Data.</i>
S-05	1	Sec.4A BOQ				According to BOQ, GI(geotechnical investigation) length is 6,343m. Please also provide total borehole number for GI.	<i>Bidders are advised that the total number of boreholes will be determined by the actual ground conditions and shall be assessed by the bidder from geotechnical information provided</i>
S-05	2	Section 6 IB appendix 12-2	Page 3	B. During deployment		This order which is No.39 mentioned 'quarter' for work's safety during deployment. Please clarify that the meaning of the 'quarter'. (ie. Quarter means construction site or accommodation in local area)	<i>Bidder is advised that "Quarter" means accommodation on the site for people employed on the project. It excludes accommodation in the local area as Order No. 39 requires people going off site to follow the protocols for "Prior to Deployment" on return to site as described in paragraphs 2 and 3.</i>
S-05	2	Section 6 TS	TS-200-52	204.2.6.2 204.2.6.3 206.18.3.2 217.2.2		Please provide the detail information of 'Licensed professional engineer' and 'Registered professional engineer'	<i>Bidder is advised to follow Philippine Engineer Licensing practice in relation to this requirement.</i>
S-05	2	Section 6 Drawing	VIA00-4, VIA00-40			Pile cap type of P-694 and P-695 are BC03-4M according to NSRP-DWG-VIA05-ST-0101. But their shape and number of pile are different in the NSRP-DWG-VIA05-ST-0101. In addition. Type BC03-4M isn't provide to bidder. Please Clarify and provide the drawing of type BC03-4M.	<i>Bidder is referred to Table 1 of the drawing of NSRP-DWG-BC03-ST-4011 for the shape and number of piles of the pile cap type of P-694 and P-695, NSRP-DWG-VIA00-ST-0301,0302 for the pile cap type.</i>
S-05	2	Section 6 Drawing	VIA00-167, VIA00-169			There are two emergency staircases which are #4 and #5. The height of Beam FTB1 is 1200mm in the NSRP-DWG-VIA00-ST-1690. But its dimension is 600mm in the NSRP-DWG-VIA00-ST-1692. Please, clarify it.	<i>Bidder is advised that in the NSRP-DWG-VIA00-ST-1690 drawing, the height of the corner including the pile joint is 1200 mm. The height of the FTB1 beam is 600 mm.</i>
S-05	1	Sec.4A BOQ		General	Reinforcement Steel (Lap Splicing)	1) Please clarify that the lap splicing quantities are included in reinforcement steel of BOQ or not.  2) Please clarify that the lap splicing quantities will be paid by Employer or not.	<i>1) Bidder is advised that the quantities of lap splicing shown in the drawings are included in reinforcement steel of BOQ. 2) Bidder is advised that the quantities of lap splicing stated in the drawings issued for contract will be paid by the Employer.</i>

**CP S04-07 Responses to Clarification Requests (Batch 2)**

Packages	Vol	Sec	Page No.	Clause No./Title	Reference Text (if necessary)	Clarification Request	Final Response
S-05	2	Sec.6	GS8	104.1.4 Medical Facilities	It/they shall be provided with an ambulance(s) with full-time drivers as detailed in Appendix 5 hereto.	According to Appendix 5, Please provide us related requirements regarding ambulance(s).	<i>Bidder is advised as follows; Clarification for Section 6 GS8, 104.1.4 Medical Facilities, requirements for ambulances: The Bidder shall assess the requirements for the Project Package considering location, length of project Right of Way, proposed locations for Offices, accommodation and welfare facilities, fabrication facilities and the number of workers to be employed for the Works, local off-site medical facilities, training of staff and supervision, and then assess what facilities will be required including medical staff and facilities on site including emergency vehicles such as ambulances. The Bidder shall be responsible for assessing the logistics requirements, price accordingly and if successful, implement its proposals. Facilities located off-site may be used provided satisfactory terms are established for health protocols, response times and the provision of vehicles suitable for accessing all locations on site in all weather and conditions, be available 24 hours a day 7 days a week.</i>
S-05	2	Sec.6	GS35	113.2 Measurement and Payment	Lump Sum Fixed charges will be once only payments for mobilization and demobilization. Lump Sum Time related charges will be spread over the Contract Period.	Please clarify that Utility treatment work is Provisional sum or Lump sum? There are discrepancy between BOQ and GS 113.2.	<i>Bidder is referred to Item GS113 of Bill No.1. Utility treatment work &amp; Utilities Relocation and Protection should be paid in Provisional sum.</i>
S-05	2	Sec.6	GS90	128.1 Defect Liability	The Warranty Period for contractual spare parts, special tools and testing equipment or any other item of equipment delivered shall be thirty six (36) months (1,095 calendar days) from the date of delivery and acceptance by the Employer of such spare parts, tools and test equipment or any other equipment.	Please clarify the specific quantity for each spare parts items.	<i>Bidders are advised to refer to relevant General Specifications and Technical Specifications to determine spare parts requirements.</i>

**CP S04-07 Responses to Clarification Requests (Batch 2)**

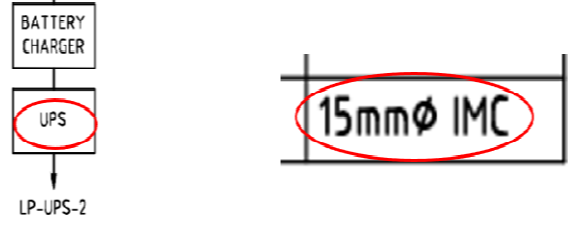
Packages	Vol	Sec	Page No.	Clause No./Title	Reference Text (if necessary)	Clarification Request	Final Response
S-05	2	Drawing		NSRP-DWG-VIA00-ST-1201	Temporary Prestress Bar	As per drawing, NSRP-DWG-VIA00-ST-1201, type of temporary prestress bar for PSM viaduct is 40Ø, 29Ø VSL CT Stress Bar.  Please clarify bidder can propose equivalent type of prestress bar or the Client has any design preference.	<i>Bidder can propose the prestressing type for use. The Contractor will have a responsibility of the equivalent type of the system. Please refer to "TS208.3".</i>
S-05	2	Drawing		NSRP-DWG-VIA00-ST-1121	Post-Tensioning	As per prestressing notes on drawing, NSRP-DWG-VIA00-ST-1121, it states that "The bridge superstructure has been detailed for the Freyssinet post-tensioning system".  Please clarify bidder can propose equivalent post-tensioning system or the Client has any design preference.	<i>Bidder can propose the post-tensioning system for use. The Contractor will have a responsibility of the equivalent type of the system.</i>
S-05	2	Section 6 II Drawing VIA00	27, 28		All Table	Please provide pile reinforcement type for all each piers to bidder.	<i>Bidder is referred to pile schedule of VIA 05 Drawing sets.</i>
S-05	2	02.Book2. 04-S05 ELEC. CPS-05-03-BIN- EL	- NSRP- DWG- BIN -EL- 5701	FIRE DETECTION AND ALARM SYSTEM SCHEMATIC DIAGRAM		 <p>We can't find out some items in the BOQ. But the items are in the relevant drawings. Please clarify that as following items; - UPS - 15 mm dia IMC Conduit</p>	<i>Bidder is advised that Pay item for UPS is included in 706(15)ah BIN - LP UPS incl 30kVA UPS. Quantity for 15mm dia IMC is already included in 707(4)i 20mm dia IMC as circuit LP-UPS/2</i>

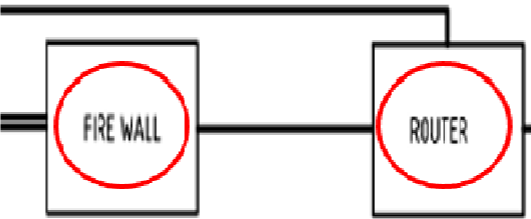
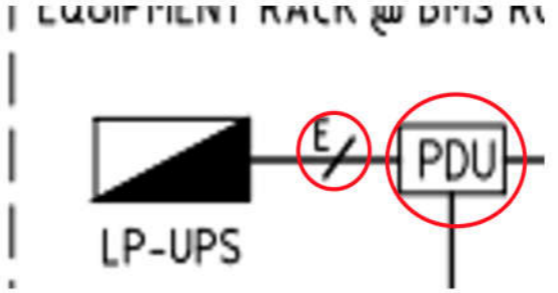
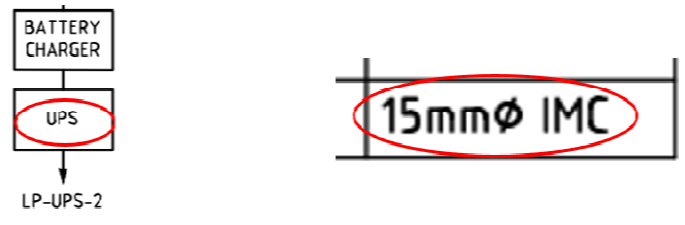

**CP S04-07 Responses to Clarification Requests (Batch 2)**

Packages	Vol	Sec	Page No.	Clause No./Title	Reference Text (if necessary)	Clarification Request	Final Response
S-05	2	02.Book2.04-S05 ELEC. CPS-05-03-BIN-EL	- NSRP-DWG-BIN -EL-5803	CCTV SYSTEM DIAGRAM UNPAID AREA		 <p>We can't find out some items in the BOQ. But the items are in the relevant drawings. Please clarify that as following items; - FIRE WALL and ROUTER</p>	<i>Bidder is advised that cost for Fire wall &amp; router is included in pay item 715(1)e Server</i>
S-05	2	02.Book2.04-S05 ELEC. CPS-05-03-BIN-EL	- NSRP-DWG-BIN -EL-5825	ACCESS CONTROL SYSTEM SCHEMATIC DIAGRAM		 <p>We can't find out some items in the BOQ. But the items are in the relevant drawings. Please clarify that as following items; - PDU and cable E</p>	<i>Bidder is advised that cost for PDU &amp; cable E is included in pay item 715(2)b Access Control Panel</i>
S-05	2	02.Book2.04-S05 ELEC. CP S-05-03-PTA_EL	- NSRP-DWG-PTA -EL-5701	FIRE DETECTION AND ALARM SYSTEM SCHEMATIC DIAGRAM		 <p>We can't find out some items in the BOQ. But the items are in the relevant drawings. Please clarify that as following items; - UPS - 15 mm dia IMC Conduit</p>	<i>Bidder is advised that pay item for UPS is included in 706(14)ae PTA - LP UPS incl 30kVA UPS. Quantity for 15mm dia IMC is already included in 707(4)i 20mm dia IMC as circuit LP-UPS/2.</i>

**CP S04-07 Responses to Clarification Requests (Batch 2)**

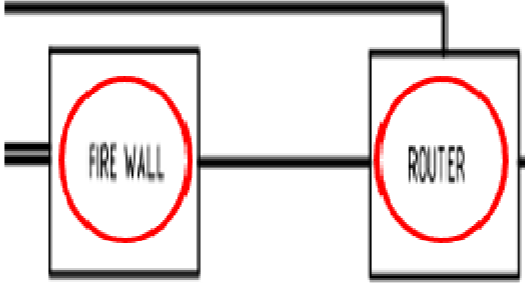
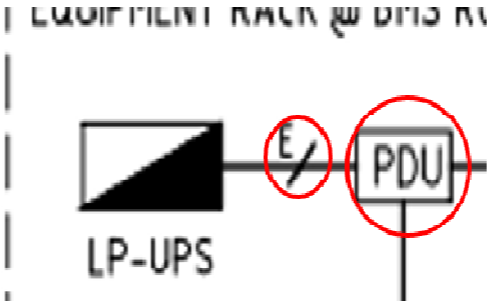
Packages	Vol	Sec	Page No.	Clause No./Title	Reference Text (if necessary)	Clarification Request	Final Response
S-05	2	02.Book2. 04-S05 ELEC. CP S-05-03- PTA_EL	- NSRP- DWG- PTA -EL- 5803	CCTV SYSTEM DIAGRAM UNPAID AREA		 <p>We can't find out some items in the BOQ. But the items are in the relevant drawings. Please clarify that as following items; - FIRE WALL and ROUTER</p>	<i>Bidder is advised that cost for Fire wall &amp; router is included in pay item 715(1)e Server</i>
S-05	2	02.Book2. 04-S05 ELEC. CP S-05-03- PTA_EL	- NSRP- DWG- PTA-EL- 5825	ACCESS CONTROL SYSTEM SCHEMATIC DIAGRAM		 <p>We can't find out some items in the BOQ. But the items are in the relevant drawings. Please clarify that as following items; - PDU and cable E</p>	<i>Bidder is advised that cost for cable E is included in pay item 715(2)b Access Control Panel</i>

**CP S04-07 Responses to Clarification Requests (Batch 2)**

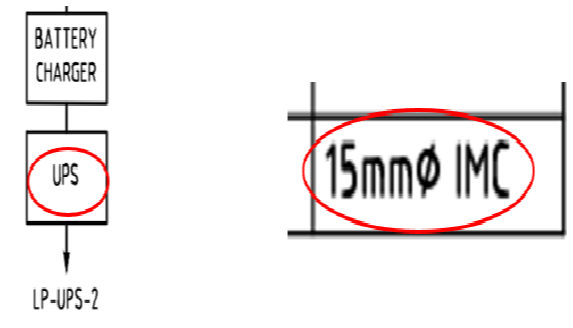
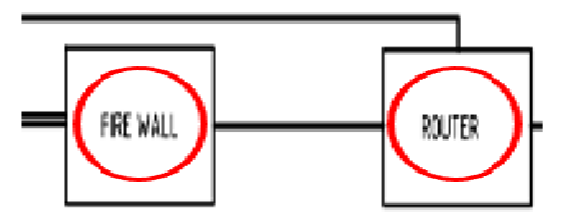
Packages	Vol	Sec	Page No.	Clause No./Title	Reference Text (if necessary)	Clarification Request	Final Response
S-05	2	02.Book2. 04-S05 ELEC. CPS-05-03-SPO- EL.	- NSRP- DWG- SPO -EL- 5701	FIRE DETECTION AND ALARM SYSTEM SCHEMATIC DIAGRAM		 <p>We can't find out some items in the BOQ. But the items are in the relevant drawings. Please clarify that as following items; - UPS - 15 mm dia IMC Conduit</p>	<p><i>Bidder is advised that pay item for UPS is included in 706(13)ak SPO - LP UPS incl 30kVA UPS. Quantity for 15mm dia IMC is already included in 707(4)i 20mm dia IMC as circuit LP-UPS/2.</i></p>
S-05	2	02.Book2. 04-S05 ELEC. CPS-05-03-SPO- EL.	- NSRP- DWG- SPO -EL- 5803	CCTV SYSTEM DIAGRAM UNPAID AREA		 <p>We can't find out some items in the BOQ. But the items are in the relevant drawings. Please clarify that as following items; - FIRE WALL and ROUTER</p>	<p><i>Bidder is advised that cost for Fire wall &amp; router is included in pay item 715(1)e Server</i></p>

**CP S04-07 Responses to Clarification Requests (Batch 2)**

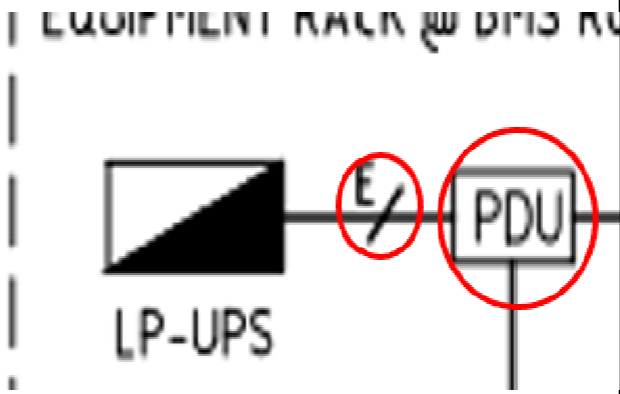
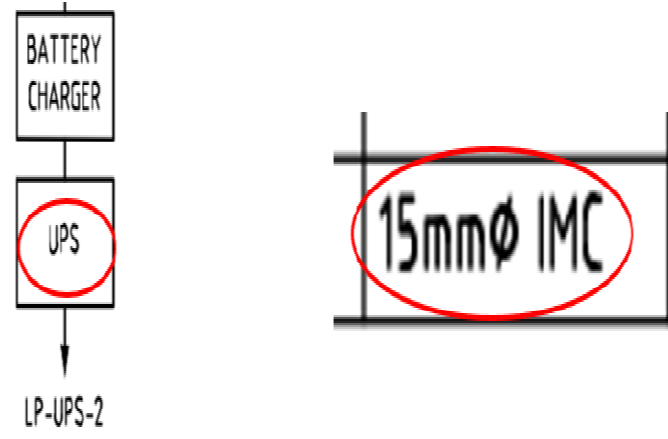
Packages	Vol	Sec	Page No.	Clause No./Title	Reference Text (if necessary)	Clarification Request	Final Response
S-05	2	02.Book2. 04-S05 ELEC.	- NSRP- DWG- CPS-05-03-SPO- EL. 5825	ACCESS CONTROL SYSTEM SCHEMATIC DIAGRAM		 <p>EQUIPMENT RACK W/ DMS RU</p> <p>LP-UPS</p> <p>PDU</p> <p>We can't find out some items in the BOQ. But the items are in the relevant drawings. Please clarify that as following items; - PDU and cable E</p>	<p><i>Bidder is advised that cost for PDU &amp; cable E is included in pay item 715(2)b Access Control Panel</i></p>
S-05	2	02.Book2. 04-S05 ELEC.	- NSRP- DWG- CPS-05-03-SRO- EL. 5701	FIRE DETECTION AND ALARM SYSTEM SCHEMATIC DIAGRAM		 <p>BATTERY CHARGER</p> <p>UPS</p> <p>LP-UPS-2</p> <p>15mmØ IMC</p> <p>We can't find out some items in the BOQ. But the items are in the relevant drawings. Please clarify that as following items; - UPS - 15 mm dia IMC Conduit</p>	<p><i>Bidder is advised that pay item for UPS is included in 706(13)ak SPO - LP UPS incl 30kVA UP. Quantity for 15mm dia IMC is already included in 707(4)i 20mm dia IMC as circuit LP-UPS/2.</i></p>

**CP S04-07 Responses to Clarification Requests (Batch 2)**

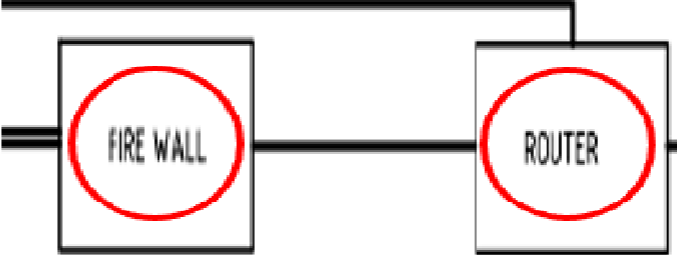
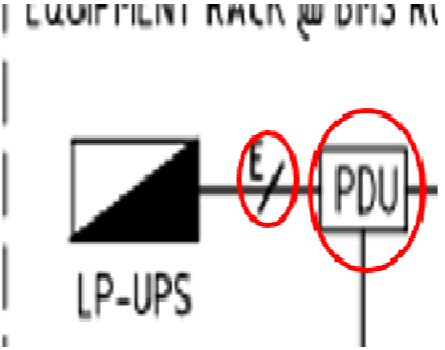
Packages	Vol	Sec	Page No.	Clause No./Title	Reference Text (if necessary)	Clarification Request	Final Response
S-05	2	02.Book2. 04-S05 ELEC. CPS-05-03-SRO-EL	- NSRP- DWG- SRO -EL- 5803	CCTV SYSTEM DIAGRAM UNPAID AREA		 <p>We can't find out some items in the BOQ. But the items are in the relevant drawings. Please clarify that as following items; - FIRE WALL and ROUTER</p>	<i>Bidder is advised that cost for Fire wall &amp; router is included in pay item 715(1)e Server</i>
S-05	2	02.Book2. 04-S05 ELEC. CPS-05-03-SRO-EL	- NSRP- DWG- SRO-EL- 5825	ACCESS CONTROL SYSTEM SCHEMATIC DIAGRAM		 <p>We can't find out some items in the BOQ. But the items are in the relevant drawings. Please clarify that as following items; - PDU and cable E</p>	<i>Bidder is advised that cost for PDU &amp; cable E is included in pay item 715(2)b Access Control Panel</i>

**CP S04-07 Responses to Clarification Requests (Batch 2)**

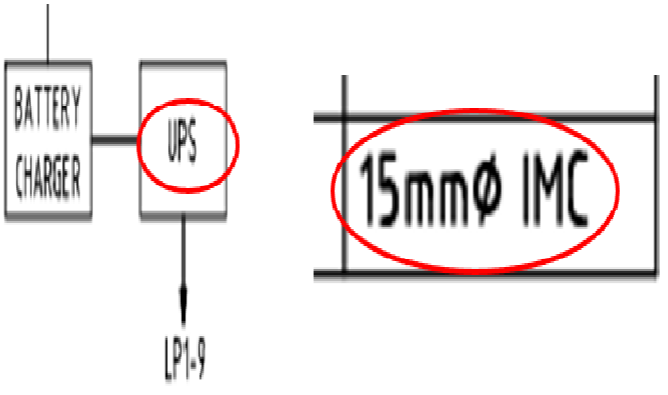
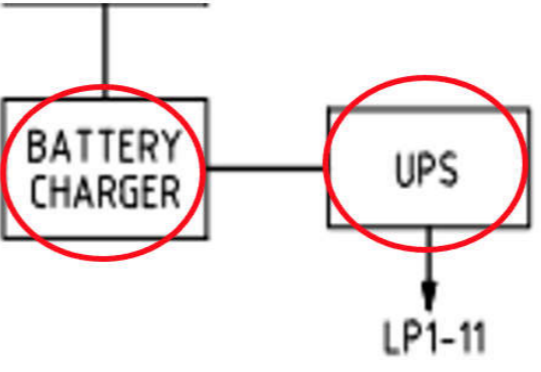
Packages	Vol	Sec	Page No.	Clause No./Title	Reference Text (if necessary)	Clarification Request	Final Response
S-05	2	02.Book2. 04-S05 ELEC. CPS-05-03- SS_Electrical_S S_10-14	- NSRP- DWG- SS10 -EL- 5701	FIRE DETECTION AND ALARM SYSTEM SCHEMATIC DIAGRAM		 <p>We can't find out some items in the BOQ. But the items are in the relevant drawings. Please clarify that as following items; - UPS - 15 mm dia IMC Conduit</p>	<i>Bidder is advised that cost for UPS is included in pay item 716(8)b Fire Alarm Control Panel for Substation. Quantity is included in pay item 707(4)i 20mm dia IMC as circuit LP1 -9</i>
S-05	2	02.Book2. 04-S05 ELEC. CPS-05-03- SS_Electrical_S S_10-14	- NSRP- DWG- SS10 -EL- 5801	ACCESS CONTROL SYSTEM SCHEMATIC DIAGRAM		 <p>We can't find out some items in the BOQ. But the items are in the relevant drawings. Please clarify that as following items; - UPS - Battery Charger</p>	<i>Bidder is advised that cost for UPS is included in pay item 715(2)b Access Control Panel &amp; cost for Battery Charger is included in pay item 715(2)i Battery</i>

**CP S04-07 Responses to Clarification Requests (Batch 2)**

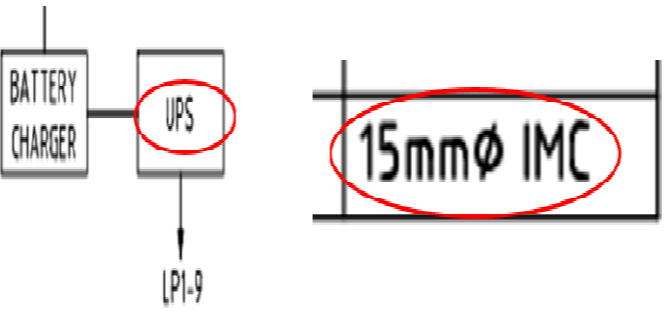
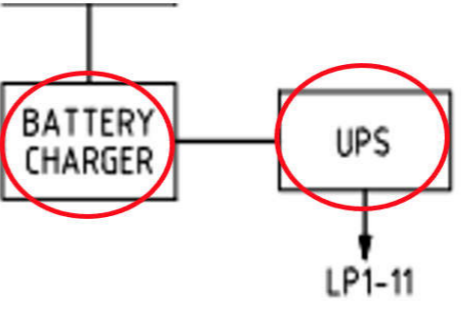
Packages	Vol	Sec	Page No.	Clause No./Title	Reference Text (if necessary)	Clarification Request	Final Response
S-05	2	02.Book2. 04-S05 ELEC. CPS-05-03- SS_Electrical_S S_10-14	- NSRP- DWG- SS11 -EL- 5701	FIRE DETECTION AND ALARM SYSTEM SCHEMATIC DIAGRAM		 <p>We can't find out some items in the BOQ. But the items are in the relevant drawings. Please clarify that as following items; - UPS - 15 mm dia IMC Conduit</p>	<p><i>Bidder is advised that cost for UPS is included in pay item 716(8)b Fire Alarm Control Panel for Substation. Quantity is included in pay item 707(4)i 20mm dia IMC as circuit LP1 -9</i></p>
S-05	2	02.Book2. 04-S05 ELEC. CPS-05-03- SS_Electrical_S S_10-14	- NSRP- DWG- SS11-EL- 5801	ACCESS CONTROL SYSTEM SCHEMATIC DIAGRAM		 <p>We can't find out some items in the BOQ. But the items are in the relevant drawings. Please clarify that as following items; - UPS - Battery Charger</p>	<p><i>Bidder is advised that cost for UPS is included in pay item 715(2)b Access Control Panel &amp; cost for Battery Charger is included in pay item 715(2)i Battery</i></p>

**CP S04-07 Responses to Clarification Requests (Batch 2)**

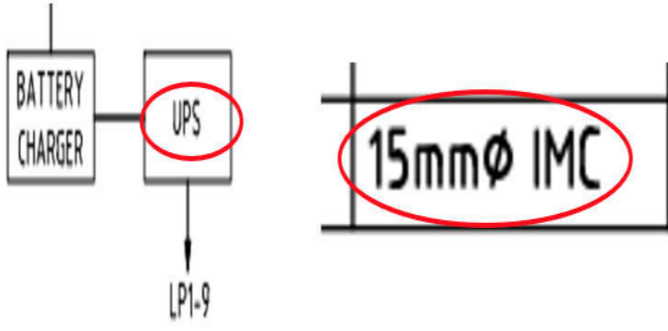
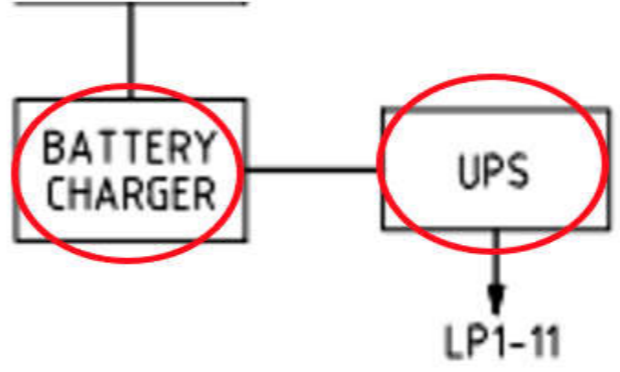
Packages	Vol	Sec	Page No.	Clause No./Title	Reference Text (if necessary)	Clarification Request	Final Response
S-05	2	02.Book2. 04-S05 ELEC. CPS-05-03- SS_Electrical_S S_10-14	- NSRP- DWG- SS12 -EL- 5701	FIRE DETECTION AND ALARM SYSTEM SCHEMATIC DIAGRAM		 <p>We can't find out some items in the BOQ. But the items are in the relevant drawings. Please clarify that as following items; - UPS - 15 mm dia IMC Conduit</p>	<p><i>Bidder is advised that cost for UPS is included in pay item 716(8)b Fire Alarm Control Panel for Substation. Quantity is included in pay item 707(4)i 20mm dia IMC as circuit LPI -9</i></p>
S-05	2	02.Book2. 04-S05 ELEC. CPS-05-03- SS_Electrical_S S_10-14	- NSRP- DWG- SS12 -EL- 5801	ACCESS CONTROL SYSTEM SCHEMATIC DIAGRAM		 <p>We can't find out some items in the BOQ. But the items are in the relevant drawings. Please clarify that as following items; - UPS - Battery Charger</p>	<p><i>Bidder is advised that cost for UPS is included in pay item 715(2)b Access Control Panel &amp; cost for Battery Charger is included in pay item 715(2)i Battery</i></p>

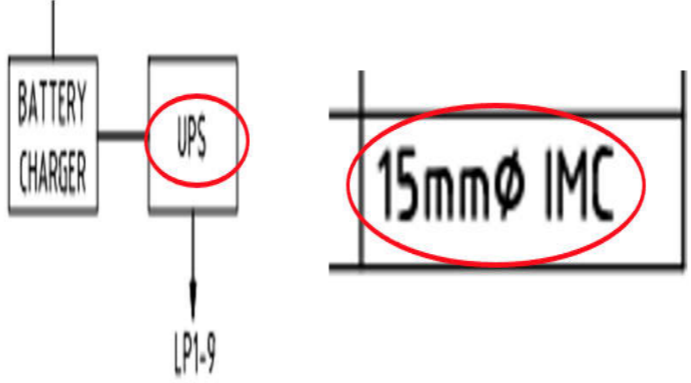
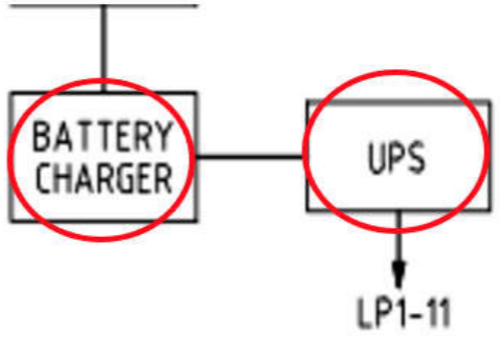

**CP S04-07 Responses to Clarification Requests (Batch 2)**

Packages	Vol	Sec	Page No.	Clause No./Title	Reference Text (if necessary)	Clarification Request	Final Response
S-05	2	02.Book2. 04-S05 ELEC. CPS-05-03- SS_Electrical_S S_10-14	- NSRP- DWG- SS13 -EL- 5701	FIRE DETECTION AND ALARM SYSTEM SCHEMATIC DIAGRAM		 <p>We can't find out some items in the BOQ. But the items are in the relevant drawings. Please clarify that as following items; - UPS - 15 mm dia IMC Conduit</p>	<p><i>Bidder is advised that cost for UPS is included in pay item 716(8)b Fire Alarm Control Panel for Substation. Quantity is included in pay item 707(4)i 20mm dia IMC as circuit LPI -9</i></p>
S-05	2	02.Book2. 04-S05 ELEC. CPS-05-03- SS_Electrical_S S_10-14	- NSRP- DWG- SS13-EL- 5801	ACCESS CONTROL SYSTEM SCHEMATIC DIAGRAM		 <p>We can't find out some items in the BOQ. But the items are in the relevant drawings. Please clarify that as following items; - UPS - Battery Charger</p>	<p><i>Bidder is advised that cost for UPS is included in pay item 715(2)b Access Control Panel &amp; cost for Battery Charger is included in pay item 715(2)i Battery</i></p>

**CP S04-07 Responses to Clarification Requests (Batch 2)**

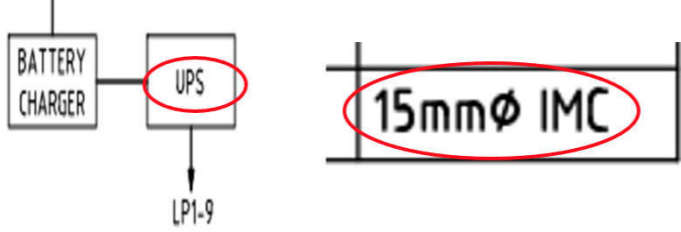
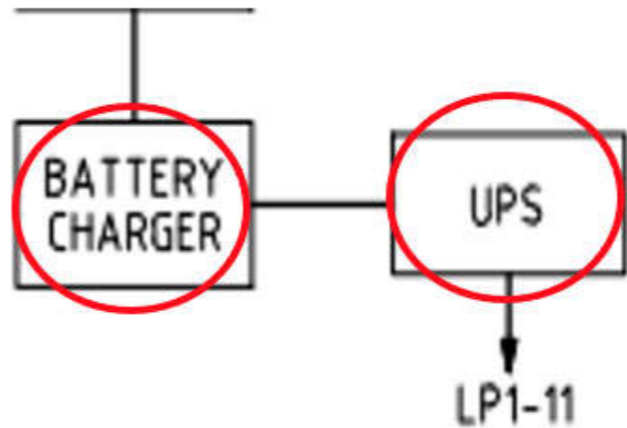
Packages	Vol	Sec	Page No.	Clause No./Title	Reference Text (if necessary)	Clarification Request	Final Response
S-05	2	02.Book2. 04-S05 ELEC. CPS-05-03- SS_Electrical_S S_10-14	- NSRP- DWG- SS14 -EL- 5701	FIRE DETECTION AND ALARM SYSTEM SCHEMATIC DIAGRAM		 <p>We can't find out some items in the BOQ. But the items are in the relevant drawings. Please clarify that as following items; - UPS - 15 mm dia IMC Conduit</p>	<i>Bidder is advised that cost for UPS is included in pay item 716(8)b Fire Alarm Control Panel for Substation. Quantity is included in pay item 707(4)i 20mm dia IMC as circuit LPI -9</i>
S-05	2	02.Book2. 04-S05 ELEC. CPS-05-03- SS_Electrical_S S_10-14	- NSRP- DWG- SS14-EL- 5801	ACCESS CONTROL SYSTEM SCHEMATIC DIAGRAM		 <p>We can't find out some items in the BOQ. But the items are in the relevant drawings. Please clarify that as following items; - UPS - Battery Charger</p>	<i>Bidder is advised that cost for UPS is included in pay item 715(2)b Access Control Panel &amp; cost for Battery Charger is included in pay item 715(2)i Battery</i>

**CP S04-07 Responses to Clarification Requests (Batch 2)**

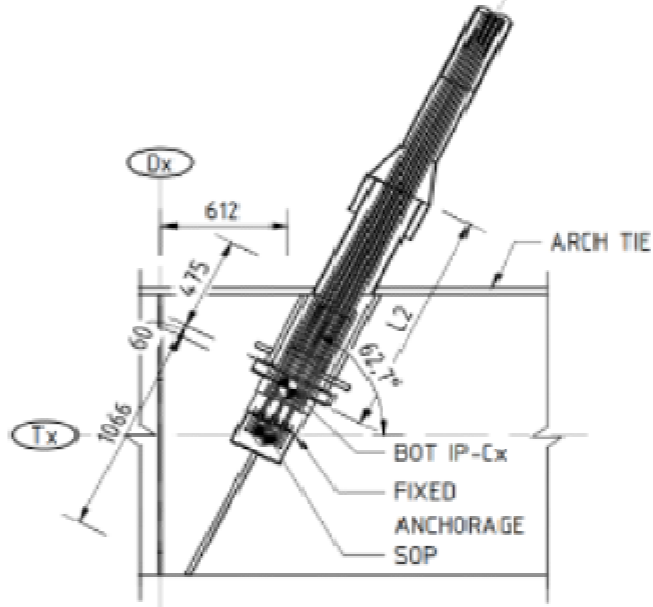
Packages	Vol	Sec	Page No.	Clause No./Title	Reference Text (if necessary)	Clarification Request	Final Response
S-06	2	Section 6 II Drawings	BR215- ST-0241			<p>[Steel Tied Arch Bridge] The design space from anchoring point is 1,066mm in the DWG. No. BR215-ST-0241. It is too small space for ISO tensioning of stay cable</p> <p>Please clarify the space for ISO tensioning of stay cable.</p> 	<p><i>Bidders are advised that the drawing of the cable is a reference only, the construction will be carried out using the jack according to the anchorage of the cable adopted by the contractor.</i></p>
S-06	2	Section 6	TS 200			<p>[Steel Tied Arch Bridge] There are not any technical Specification for stay cable of steel tied arch bridge in TS 200. Please provide nominal diameter and tensile strength of strand for stay cable and any other requirements.</p>	<p><i>Bidder is advised that the technical specifications of the cable are shown in NOTES of "NSRP-DWG-BR-215-ST-0243". It is provided by the "Post-Tensioning Institute (PTI)".</i></p>
S-06	2	Section 6	SOW -15			<p>Some plots of land adjacent to the Project alignment has been identified by the Employer as potentially available and these are shown on the report "SCRP POTENTIAL CASTING YARD MARCH, 2020" Please provide the report of "SCRP POTENTIAL CASTING YARD MARCH, 2020".</p>	<p><i>Bidder is referred to Site Data 10.19 Sites for Contractors</i></p>
S-06	2	Civil drawing				<p>In the drawing of Viaduct VIA06, there is the granular fill in the U-type structure. Please provide which material require? And what is the requirement of specification?</p>	<p><i>Bidders are referred to Technical Specification TS 106</i></p>
S-06	2	General				<p>Please provide the applied design soil properties for Temporary works design.</p>	<p><i>Bidder is responsible for design of all temporary facility work. A geotechnical investigation report is provided under Site Data.</i></p>

**CP S04-07 Responses to Clarification Requests (Batch 2)**

Packages	Vol	Sec	Page No.	Clause No./Title	Reference Text (if necessary)	Clarification Request	Final Response
S-06	2	Section 6 IB appendix 12-2	Page 3	B. During deployment		This order which is No.39 mentioned 'quarter' for work's safety during deployment. Please clarify that the meaning of the 'quarter'. (ie. Quarter means construction site or accommodation in local area)	<i>Bidder is advised that "Quarter" means accommodation on the site for people employed on the project. It excludes accommodation in the local area as Order No. 39 requires people going off site to follow the protocols for "Prior to Deployment" on return to site as described in paragraphs 2 and 3.</i>
S-06	2	Section 6 Drawing	30, 31		CP S-06_Vol-4 Site Data - Topo Surveys	From P-1234 to P-1236 and from P-1244 to P1247, there are no plan to be diverted for existing tracks. These pile caps are interfaced with existing tracks. Please clarify it to bidders.	<i>Bidder is advised that the PNR track will be also diverted in this section. The end point of diversion will located south side from end of CPS06.The bidder should take into account of the actual condition of PNR relocated alignment by PNR</i>
S-06	2	Section 6 Drawing	32		CP S-06_Vol-4 Site Data - Topo Surveys	From P-1253N to P-1259N, there are no plan to be diverted for existing tracks. Calamba station is interfaced with existing tracks. Please clarify it to bidders.	<i>Bidder is advised that the PNR track will be also diverted in this section. The end point of diversion will located south side from end of CPS06.The bidder should take into account of the actual condition of PNR relocated alignment by PNR</i>
S-06	2	Section 6 TS	TS-200-52	204.2.6.2 204.2.6.3 206.18.3.2 217.2.2		Please provide the detail information of 'Licensed professional engineer' and 'Registered professional engineer'	<i>Bidder is advised to follow Philippine Engineer Licensing practice in relation to this requirement.</i>
S-06	2	Section 6 Drawing	VIA00-167, VIA00-169			There are two emergency staircases which are #6 and #7. The height of Beam FTB1 is 1200mm in the NSRP-DWG-VIA00-ST-1693. But its dimension is 600mm in the NSRP-DWG-VIA00-ST-1695. Please, clarify it.	<i>Bidder is advised that in the NSRP-DWG-VIA00-ST-1693 drawing, the height of the corner including the pile joint is 1200 mm. The height of the FTB1 beam is 600 mm.</i>
S-06	1	Sec.4A BOQ		General	Reinforcement Steel (Lap Splicing)	1) Please clarify that the lap splicing quantities are included in reinforcement steel of BOQ or not.  2) Please clarify that the lap splicing quantities will be paid by Employer or not.	<i>1) Bidder is advised that the quantities of lap splicing shown in the drawings are included in reinforcement steel of BOQ. 2) Bidder is advised that the quantities of lap splicing stated in the drawings issued for contract will be paid by the Employer.</i>

**CP S04-07 Responses to Clarification Requests (Batch 2)**

Packages	Vol	Sec	Page No.	Clause No./Title	Reference Text (if necessary)	Clarification Request	Final Response
S-06	2	Sec.6	GS8	104.1.4 Medical Facilities	It/they shall be provided with an ambulance(s) with full-time drivers as detailed in Appendix 5 hereto.	According to Appendix 5, Please provide us related requirements regarding ambulance(s).	<i>Bidder is advised as follows; Clarification for Section 6 GS8, 104.1.4 Medical Facilities, requirements for ambulances: The Bidder shall assess the requirements for the Project Package considering location, length of project Right of Way, proposed locations for Offices, accommodation and welfare facilities, fabrication facilities and the number of workers to be employed for the Works, local off-site medical facilities, training of staff and supervision, and then assess what facilities will be required including medical staff and facilities on site including emergency vehicles such as ambulances. The Bidder shall be responsible for assessing the logistics requirements, price accordingly and if successful, implement its proposals. Facilities located off-site may be used provided satisfactory terms are established for health protocols, response times and the provision of vehicles suitable for accessing all locations on site in all weather and conditions, be available 24 hours a day 7 days a week.</i>
S-06	2	Sec.6	GS35	113.2 Measurement and Payment	Lump Sum Fixed charges will be once only payments for mobilization and demobilization. Lump Sum Time related charges will be spread over the Contract Period.	Please clarify that Utility treatment work is Provisional sum or Lump sum? There are discrepancy between BOQ and GS 113.2.	<i>Bidder is referred to Item GS113 of Bill No.1. Utility treatment work &amp; Utilities Relocation and Protection should be paid in Provisional sum.</i>
S-06	2	Sec.6	GS90	128.1 Defect Liability	The Warranty Period for contractual spare parts, special tools and testing equipment or any other item of equipment delivered shall be thirty six (36) months (1,095 calendar days) from the date of delivery and acceptance by the Employer of such spare parts, tools and test equipment or any other equipment.	Please clarify the specific quantity for each spare parts items.	<i>Bidders are advised to refer to refer to relevant General Specifications and Technical Specifications to determine spare parts requirements.</i>

**CP S04-07 Responses to Clarification Requests (Batch 2)**

Packages	Vol	Sec	Page No.	Clause No./Title	Reference Text (if necessary)	Clarification Request	Final Response
S-06	2	Drawing		NSRP-DWG-BR215-ST-0241	Cable for Arch Bridge	<p>As per drawing of BR215, it is mostly indicated that PWS type cable is applied for Arch Bridge. However, the drawing, NSRP-DWG-BR215-ST-0241, shows that anchorage type is HD 2000 FPH which is commonly used for MS type cable.</p> <p>Please clarify that bidder can propose equivalent type of anchorage of the cable without any design preference.</p>	<i>Bidder is advised that the cable drawing is for reference only. Bidder can propose equivalent type.</i>
S-06	2	Drawing		NSRP-DWG-VIA00-ST-1201	Temporary Prestress Bar	<p>As per drawing, NSRP-DWG-VIA00-ST-1201, type of temporary prestress bar for PSM viaduct is 40Ø, 29Ø VSL CT Stress Bar.</p> <p>Please clarify bidder can propose equivalent type of prestress bar or the Client has any design preference.</p>	<i>Bidder can propose the prestressing type for use. The Contractor will have a responsibility of the equivalent type of the system. Please refer to "TS208.3".</i>
S-06	2	Drawing		NSRP-DWG-VIA00-ST-1121	Post-Tensioning	<p>As per prestressing notes on drawing, NSRP-DWG-VIA00-ST-1121, it states that "The bridge superstructure has been detailed for the Freyssinet post-tensioning system".</p> <p>Please clarify bidder can propose equivalent post-tensioning system or the Client has any design preference.</p>	<i>Bidder can propose the post-tensioning system for use. The Contractor will have a responsibility of the equivalent type of the system.</i>
S-06	2	Section 6 II Drawing VIA00	27, 28		All Table	Please provide pile reinforcement type for all each piers to bidder.	<i>Bidder is referred to Pier schedule of VIA 06 Drawing sets.</i>

**CP S04-07 Responses to Clarification Requests (Batch 2)**

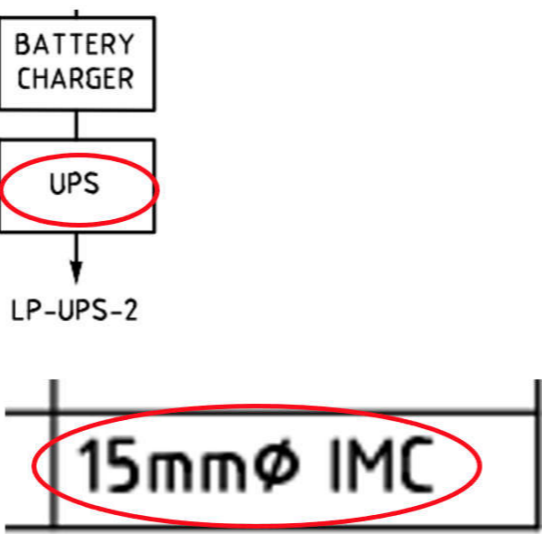
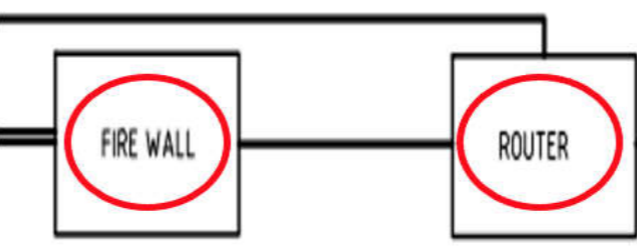
Packages	Vol	Sec	Page No.	Clause No./Title	Reference Text (if necessary)	Clarification Request	Final Response
S-06	2	02.Book2. 04-S06 ELEC. CP S-06-03- BAN-EL.	- NSRP- DWG- BAN -EL- 5701	FIRE DETECTION AND ALARM SYSTEM SCHEMATIC DIAGRAM		 <p>We can't find out some items in the BOQ. But the items are in the relevant drawings. Please clarify that as following items; - UPS - 15 mm dia IMC Conduit</p>	<p><i>Bidder is advised that pay item for UPS is included in 706(18)ae BAN - LP UPS incl 30kVA UPS. Quantity for 15mm dia IMC is already included in 707(4)i 20mm dia IMC as circuit LP-UPS/2.</i></p>
S-06	2	02.Book2. 04-S06 ELEC. CP S-06-03- BAN-EL.	- NSRP- DWG- BAN -EL- 5803	CCTV SYSTEM DIAGRAM UNPAID AREA		 <p>We can't find out some items in the BOQ. But the items are in the relevant drawings. Please clarify that as following items; - FIRE WALL and ROUTER</p>	<p><i>Bidder is advised that cost for Fire wall &amp; router is included in pay item 715(1)e Server</i></p>

**CP S04-07 Responses to Clarification Requests (Batch 2)**

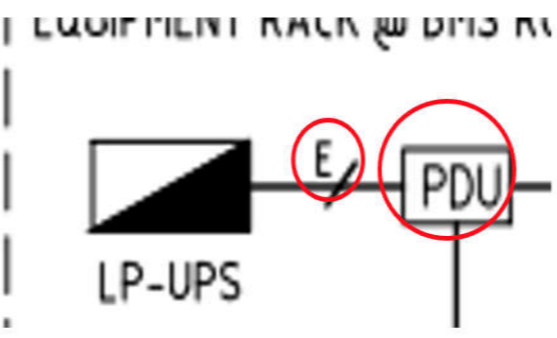
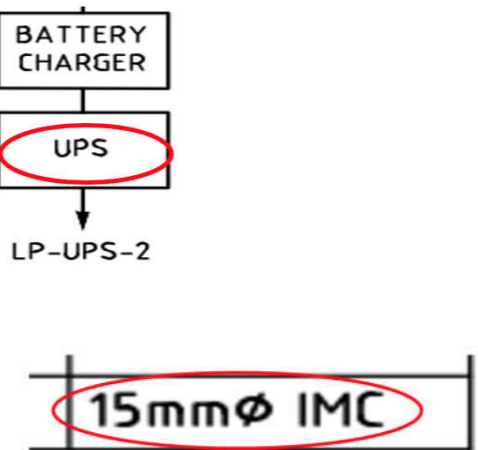
Packages	Vol	Sec	Page No.	Clause No./Title	Reference Text (if necessary)	Clarification Request	Final Response
S-06	2	02.Book2. 04-S06 ELEC. CP S-06-03- BAN-EL.	- NSRP- DWG- BAN -EL- 5825	ACCESS CONTROL SYSTEM SCHEMATIC DIAGRAM		 <p>                     We can't find out some items in the BOQ.                      But the items are in the relevant drawings.                      Please clarify that as following items;                      - PDU and cable E                 </p>	<p><i>Bidder is advised that cost for PDU &amp; cable E is included in pay item 715(2)b Access Control Panel</i></p>
S-06	2	02.Book2. 04-S06 ELEC. CP S-06-03- CAB-EL.	- NSRP- DWG- CAB -EL- 5701	FIRE DETECTION AND ALARM SYSTEM SCHEMATIC DIAGRAM		 <p>                     We can't find out some items in the BOQ.                      But the items are in the relevant drawings.                      Please clarify that as following items;                      - UPS                      - 15 mm dia IMC Conduit                 </p>	<p><i>Bidder is advised that pay item for UPS is included in 706(18)ae BAN - LP UPS incl 30kVA UPS. Quantity for 15mm dia IMC is already included in 707(4)i 20mm dia IMC as circuit LP-UPS/2.</i></p>

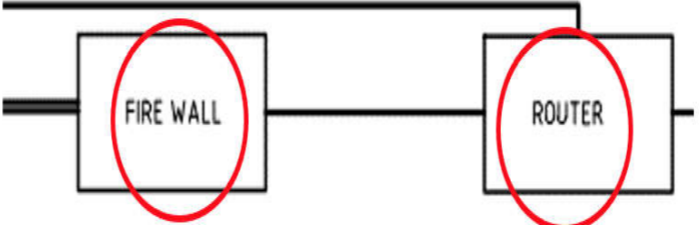
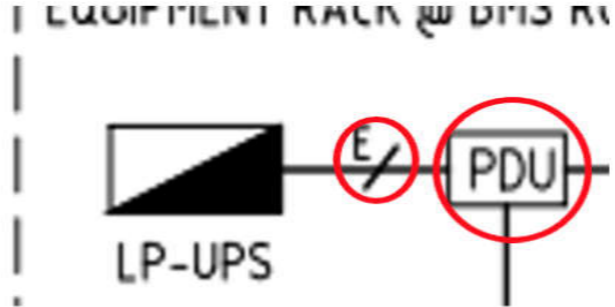

**CP S04-07 Responses to Clarification Requests (Batch 2)**

Packages	Vol	Sec	Page No.	Clause No./Title	Reference Text (if necessary)	Clarification Request	Final Response
S-06	2	02.Book2. 04-S06 ELEC. CP S-06-03- CAB-EL.	- NSRP- DWG- CAB -EL- 5803	CCTV SYSTEM DIAGRAM UNPAID AREA		 <p>We can't find out some items in the BOQ. But the items are in the relevant drawings. Please clarify that as following items; - FIRE WALL and ROUTER</p>	<p><i>Bidder is advised that cost for Fire wall &amp; router is included in pay item 715(1)e Server</i></p>
S-06	2	02.Book2. 04-S06 ELEC. CP S-06-03- CAB-EL.	- NSRP- DWG- CAB-EL- 5825	ACCESS CONTROL SYSTEM SCHEMATIC DIAGRAM		 <p>We can't find out some items in the BOQ. But the items are in the relevant drawings. Please clarify that as following items; - PDU and cable E</p>	<p><i>Bidder is advised that cost for PDU &amp; cable E is included in pay item 715(2)b Access Control Panel</i></p>

**CP S04-07 Responses to Clarification Requests (Batch 2)**

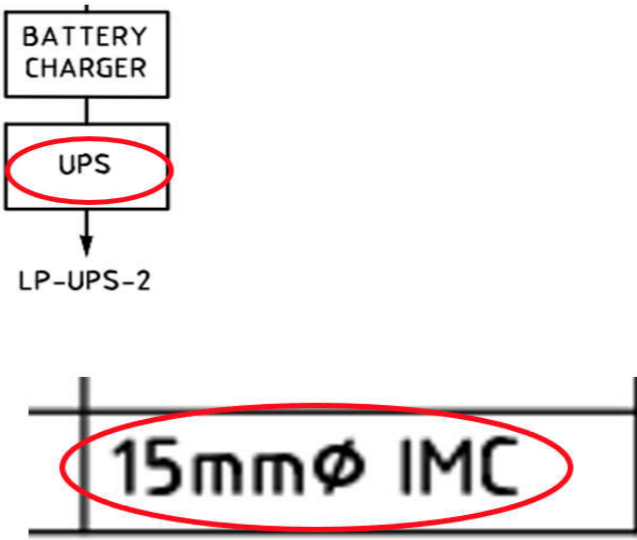
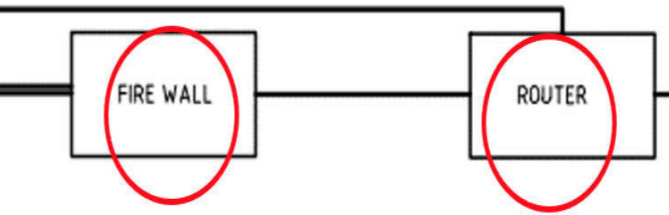
Packages	Vol	Sec	Page No.	Clause No./Title	Reference Text (if necessary)	Clarification Request	Final Response
S-06	2	02.Book2. 04-S06 ELEC. CP S-06-03- CAL-EL.	- NSRP- DWG- CAL -EL- 5701	FIRE DETECTION AND ALARM SYSTEM SCHEMATIC DIAGRAM		 <p>We can't find out some items in the BOQ. But the items are in the relevant drawings. Please clarify that as following items; - UPS - 15 mm dia IMC Conduit</p>	<p><i>Bidder is advised that pay item for UPS is included in 706(19)an CAL - LP UPS incl 30kVA UPS. Quantity for 15mm dia IMC is already included in 707(4)i 20mm dia IMC as circuit LP-UPS/2.</i></p>
S-06	2	02.Book2. 04-S06 ELEC. CP S-06-03- CAL-EL.	- NSRP- DWG- CAL -EL- 5803	CCTV SYSTEM DIAGRAM UNPAID AREA		 <p>We can't find out some items in the BOQ. But the items are in the relevant drawings. Please clarify that as following items; - FIRE WALL and ROUTER</p>	<p><i>Bidder is advised that cost for Fire wall &amp; router is included in pay item 715(1)e Server</i></p>

**CP S04-07 Responses to Clarification Requests (Batch 2)**

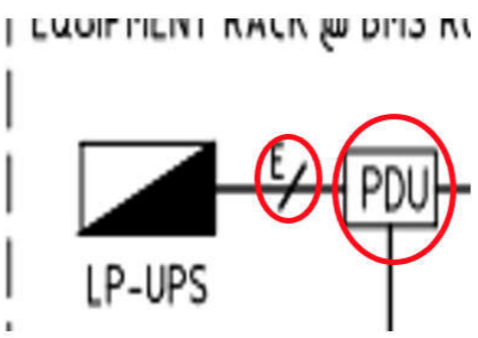
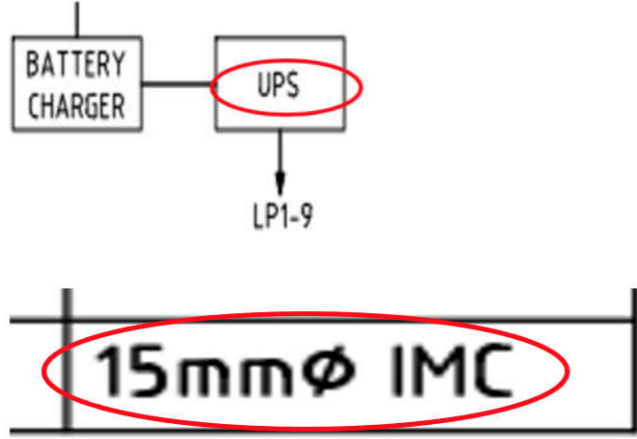
Packages	Vol	Sec	Page No.	Clause No./Title	Reference Text (if necessary)	Clarification Request	Final Response
S-06	2	02.Book2. 04-S06 ELEC. CP S-06-03- CAL-EL.	- NSRP- DWG- CAL-EL- 5825	ACCESS CONTROL SYSTEM SCHEMATIC DIAGRAM		 <p>Equipment Rack W D13 R1</p> <p>LP-UPS</p> <p>E</p> <p>PDU</p> <p>We can't find out some items in the BOQ. But the items are in the relevant drawings. Please clarify that as following items; - PDU and cable E</p>	<p><i>Bidder is advised that cost for PDU &amp; cable E is included in pay item 715(2)b Access Control Panel</i></p>
S-06	2	02.Book2. 04-S05 ELEC. CPS-06-03- SS_Electrical_S S_15-18	NSRP- DWG- SS15-EL- 5701	FIRE DETECTION AND ALARM SYSTEM SCHEMATIC DIAGRAM		 <p>BATTERY CHARGER</p> <p>UPS</p> <p>LP1-9</p> <p>15mmØ IMC</p> <p>We can't find out some items in the BOQ. But the items are in the relevant drawings. Please clarify that as following items; - UPS - 15 mm dia IMC Conduit</p>	<p><i>Bidder is advised that cost for UPS is included in pay item 716(8)b Fire Alarm Control Panel for Substation. Quantity is included in pay item 707(4)i 20mm dia IMC as circuit LP1 -9</i></p>

**CP S04-07 Responses to Clarification Requests (Batch 2)**

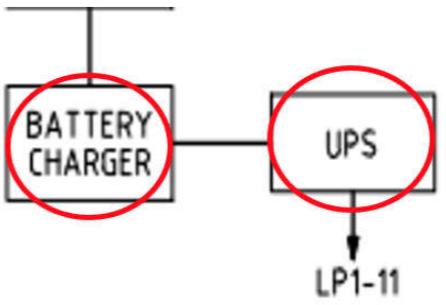
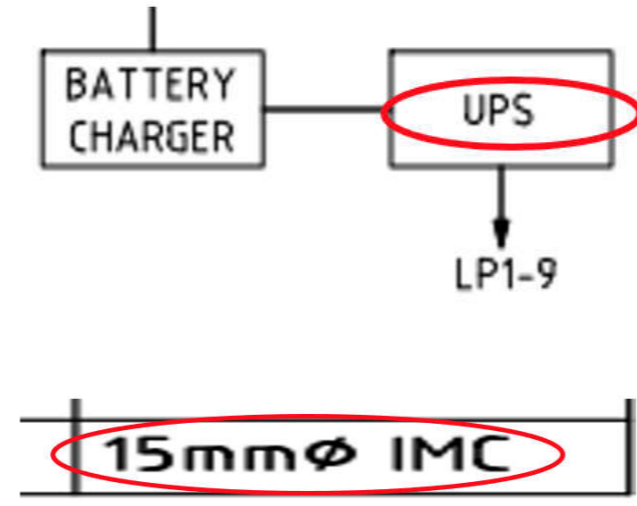
Packages	Vol	Sec	Page No.	Clause No./Title	Reference Text (if necessary)	Clarification Request	Final Response
S-06	2	02.Book2. 04-S05 ELEC. CPS-06-03- SS_Electrical_S S_15-18	NSRP- DWG- SS15-EL- 5801	ACCESS CONTROL SYSTEM SCHEMATIC DIAGRAM		 <p>We can't find out some items in the BOQ. But the items are in the relevant drawings. Please clarify that as following items; - UPS - Battery Charger</p>	<i>Bidder is advised that cost for UPS is included in pay item 715(2)b Access Control Panel &amp; cost for Battery Charger is included in pay item 715(2)i Battery</i>
S-06	2	02.Book2. 04-S05 ELEC. CPS-06-03- SS_Electrical_S S_15-18	- NSRP- DWG- SS16 -EL- 5701	FIRE DETECTION AND ALARM SYSTEM SCHEMATIC DIAGRAM		 <p>We can't find out some items in the BOQ. But the items are in the relevant drawings. Please clarify that as following items; - UPS - 15 mm dia IMC Conduit</p>	<i>Bidder is advised that cost for UPS is included in pay item 716(8)b Fire Alarm Control Panel for Substation. Quantity is included in pay item 707(4)i 20mm dia IMC as circuit LP1 -9</i>

**CP S04-07 Responses to Clarification Requests (Batch 2)**

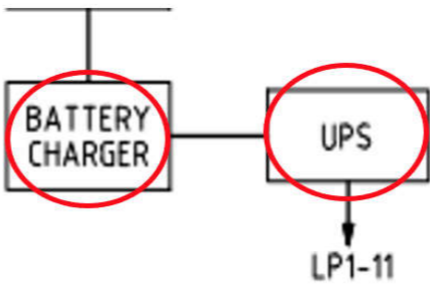
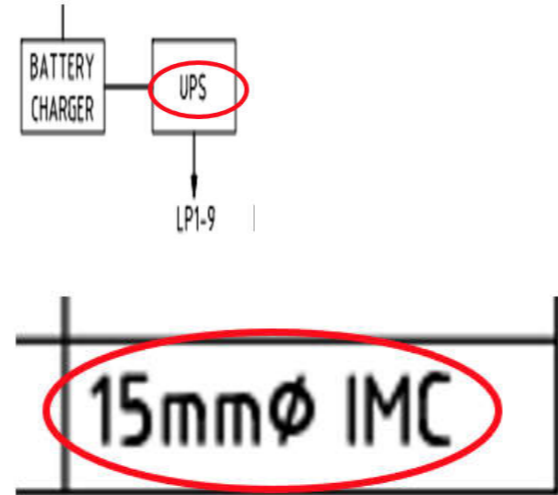
Packages	Vol	Sec	Page No.	Clause No./Title	Reference Text (if necessary)	Clarification Request	Final Response
S-06	2	02.Book2. 04-S05 ELEC. CPS-06-03- SS_Electrical_S S_15-18	- NSRP- DWG- SS16-EL- 5801	ACCESS CONTROL SYSTEM SCHEMATIC DIAGRAM		 <p>We can't find out some items in the BOQ. But the items are in the relevant drawings. Please clarify that as following items; - UPS - Battery Charger</p>	<i>Bidder is advised that cost for UPS is included in pay item 715(2)b Access Control Panel &amp; cost for Battery Charger is included in pay item 715(2)i Battery</i>
S-06	2	02.Book2. 04-S05 ELEC. CPS-06-03- SS_Electrical_S S_15-18	- NSRP- DWG- SS17 -EL- 5701	FIRE DETECTION AND ALARM SYSTEM SCHEMATIC DIAGRAM		 <p>We can't find out some items in the BOQ. But the items are in the relevant drawings. Please clarify that as following items; - UPS - 15 mm dia IMC Conduit</p>	<i>Bidder is advised that cost for UPS is included in pay item 716(8)b Fire Alarm Control Panel for Substation. Quantity is included in pay item 707(4)i 20mm dia IMC as circuit LP1 -9</i>

**CP S04-07 Responses to Clarification Requests (Batch 2)**

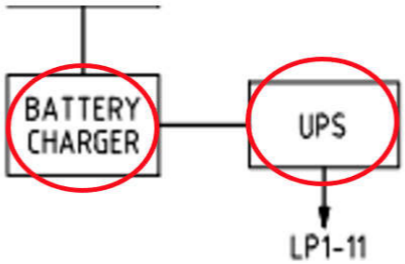
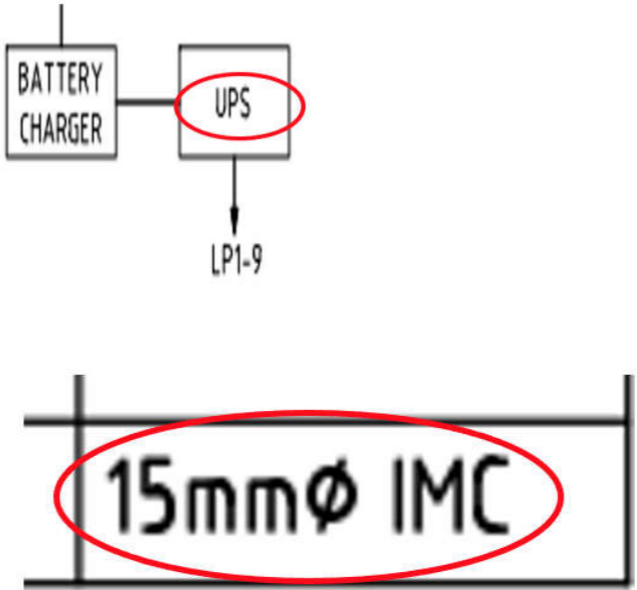
Packages	Vol	Sec	Page No.	Clause No./Title	Reference Text (if necessary)	Clarification Request	Final Response
S-06	2	02.Book2. 04-S05 ELEC. CPS-06-03- SS_Electrical_S S_15-18	- NSRP- DWG- SS17 -EL- 5801	ACCESS CONTROL SYSTEM SCHEMATIC DIAGRAM		 <p>We can't find out some items in the BOQ. But the items are in the relevant drawings. Please clarify that as following items; - UPS - Battery Charger</p>	<i>Bidder is advised that cost for UPS is included in pay item 715(2)b Access Control Panel &amp; cost for Battery Charger is included in pay item 715(2)i Battery</i>
S-06	2	02.Book2. 04-S05 ELEC. CPS-06-03- SS_Electrical_S S_15-18	- NSRP- DWG- SS18 -EL- 5701	FIRE DETECTION AND ALARM SYSTEM SCHEMATIC DIAGRAM		 <p>We can't find out some items in the BOQ. But the items are in the relevant drawings. Please clarify that as following items; - UPS - 15 mm dia IMC Conduit</p>	<i>Bidder is advised that cost for UPS is included in pay item 716(8)b Fire Alarm Control Panel for Substation. Quantity is included in pay item 707(4)i 20mm dia IMC as circuit LP1 -9</i>

**CP S04-07 Responses to Clarification Requests (Batch 2)**

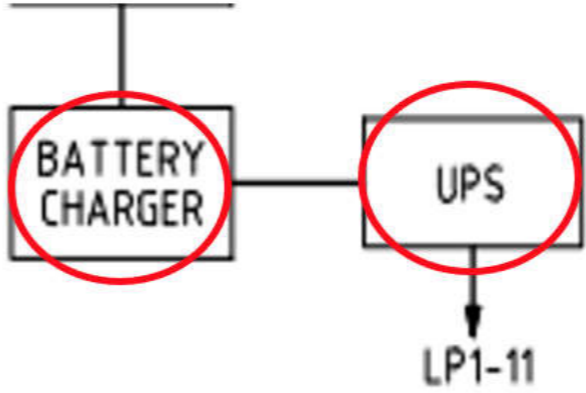
Packages	Vol	Sec	Page No.	Clause No./Title	Reference Text (if necessary)	Clarification Request	Final Response
S-06	2	02.Book2. 04-S05 ELEC. CPS-06-03- SS_Electrical_S S_15-18	- NSRP- DWG- SS18-EL- 5801	ACCESS CONTROL SYSTEM SCHEMATIC DIAGRAM		 <p>We can't find out some items in the BOQ. But the items are in the relevant drawings. Please clarify that as following items; - UPS - Battery Charger</p>	<i>Bidder is advised that Cost for UPS is included in pay item 715(2)b Access Control Panel &amp; cost for Battery Charger is included in pay item 715(2)i Battery</i>
S-04	-	Reff: EQC 05 General	-	Alignment		Where is the correct position of Alignment? Is it use existing or any different position?	<i>Bidder is requested to clarify the question</i>
S-07	-	-	-	Depot Machinery		is the maintenance tool in the depot new or is it using the existing one?  For the procurement of new equipment by whom?	<i>Maintenance tool is a general term. Bidder is requested to clarify the question further.</i>
S-07	-	-	BDS 1	Site Data		Please provide data on areas with the worst risk of flooding.	<i>Bidder is referred to Section (2) Flood Risk, Page 411 and Fig 8.1.19, Depot Design Report Site Data Item 10.17</i>
S-07	-	-	TS-100- ANNEX A-37	Topsoil	Soil source for backfill	Where is the source of topsoil for Depot, at drawing mention that contractor should be doing backfill work around 8-9 meters.	<i>Bidder is referred to TS 103 Embankment</i>